

October

SHORT WAVE CRAFT

Edited by
HUGO GERNSBACH



The 1 Tube
MINIDYNE
SUPER-REGENERATOR

See Page 338

No Aerial!
No Ground!



NOW
25¢
IN CANADA
30¢

NEW!

SUPER *Deluxe* 16-TUBE ALL-WAVE RADIO

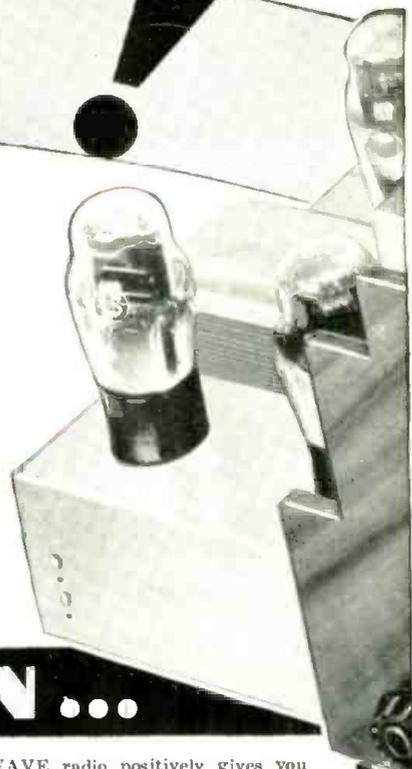

WORLD-WIDE RECEPTION ...

BUY your radio direct from the Midwest Laboratories and save from 30% to 50%. This Super 16-Tube Deluxe ALL-WAVE Radio is today's most sensational radio value! Now, it is easy to secure clear, loud-speaker reception from stations 10,000 miles and more distant. It gives you complete wave length coverage of 9 to 2000 meters (33 megacycles to 150 KC)—enabling you to secure almost magical performance! Midwest users regularly list such stations as: GSC, London—VK2ME, Sydney, Australia—JFAA, Tokio, Japan—RW50, Moscow, Russia—DJB, Berlin, etc. Never before so much radio for so little money! Send coupon today!

This super 16-Tube deluxe ALL-WAVE radio positively gives you more features and more advantages than ordinary sets selling at two to three times Midwest's sensationally low price. It puts the whole world of radio at your finger tips. It has FIVE distinct wave bands—ultra short, short, medium, broadcast and long—all tuned with a single dial! You can switch instantly from U. S. programs—Canadian, police, amateur, commercial, airplane and ship broadcasts—to the world's finest short wave programs. Don't try any radio until you get all the facts! You'll be amazed at the unbelievably low direct-from-Midwest Laboratories prices. They save you from 30% to 50%. Write for the new Midwest 1934 catalog.

40 NEW 1934 FEATURES

These sensational new features give you amazing performance, perfect realism, new beauty of tone, new wealth of power, fractional microvolt sensitivity, better than 7 KC selectivity. For example—Automatic SELECT-O-BAND (exclusive with Midwest) simplifies short wave tuning by instantly pointing out wave length of station. Some of the other features include:

- All-wave 9 to 2000 meter tuning range (33 megacycle to 150 KC)
- Five Full Wave Bands
- Illuminated Frequency Indicator
- Station Group Locator
- Dial Frequency Calibration in Kilocycles and Megacycles
- Balanced Unit Super Heterodyne Circuit

- Slow Motion, Velvety Action Tuning
- Positive Amplified Automatic Volume Control Bias Fully Delayed
- New and Improved Electro-dynamic Auditorium Type Speaker
- Latest Type, Higher Efficiency Tubes
- 7 KC Selectivity, Automatically Adjusted
- Scientifically Shielded (Coils and Switch Catacombed)
- Positive Signal Control
- Stat-O-Mit Interstation Silencer
- Super Power Class "A" Audio Amplifier
- 29 Tuned Circuits... 10 in Cascade—3 Variable
- All Police and Airplane Bands
- New Duplex—Diode—High Mu Pentodes
- Fractional Microvolt Sensitivity
- 16-Tubes... Equivalent to 18 tubes
- New Thermionic Rectifier

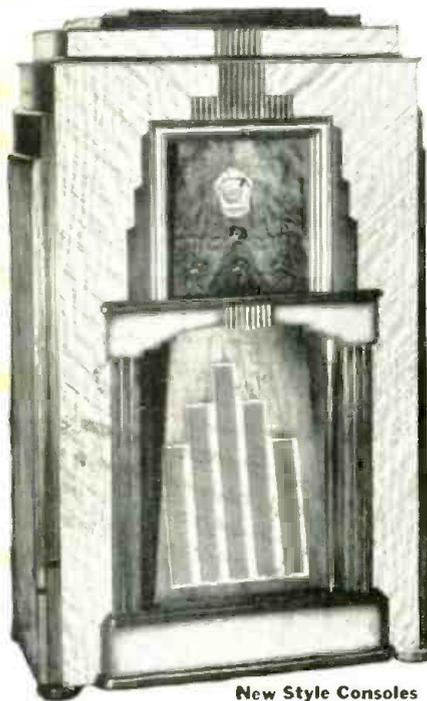

New Style Consoles

The new, big Midwest catalog shows a complete line of beautiful, artistic, deluxe consoles... in the new, modernistic designs... and priced to save you 20% to 50%. Hand made by Master Craftsmen, they lend distinction and dignity to any home. Mail the coupon today.



EXPERIENCED RADIO MAN PRAISES MIDWEST

I am firmly convinced that I have received the most radio for my money. In all my experience over a period of 15 years, I have received, on my Midwest Deluxe Model 16, reception at sufficient volume to fill entire house, from 1210 Rome, EAQ Madrid, FVA Baltimore, France GSA, GSB Liverpool, England, VK2ME Sydney, Australia, DJC-DJD Berlin, T14

Heredia, Costa Rica, HKA Barranquilla, Colombia, YVABC Caracas, Venezuela... Rio Mambou Ecuador, and numerous American and Canadian stations.—R. M. Scheid, Jr., 28 Boutinot St., Trenton, N. J.



VERIFIED RECEPTION

We think our 16-tube Midwest Set is great. We have logged at least one station on every wave length on the broadcast band. We tuned in WSB on 740 KC while XER was going on 735 KC. Have all the important phone stations in the U. S. and two in Canada. We have verification from VK2ME Sydney, Australia, VK2ME Melbourne, EAQ, Madrid, Spain, and YVABC, Caracas.

I have had the set. I consider that the Radio is worth three times what you ask for it.—L. E. W. Haze (Member I.R.E.), 1521 S. W. 7th St., Miami, Fla.



OUT-PERFORMS \$200.00 SET

An writing this unsolicited letter in regard to my Midwest radio. It is more than you claim for it in many regards. It is more selective than any radio I have come in contact with. It will whip or outperform any set over above the \$200.00 class and it must be great when your competitor awns up that it is superior to any machine that he sells. I have received South American stations and European stations during the short time that I have had the set. I consider that the Radio is worth three times what you ask for it.—L. E. W. Haze (Member I.R.E.), 1521 S. W. 7th St., Miami, Fla.

I have had the set. I consider that the Radio is worth three times what you ask for it.—L. E. W. Haze (Member I.R.E.), 1521 S. W. 7th St., Miami, Fla.

MIDWEST RADIO CORP.

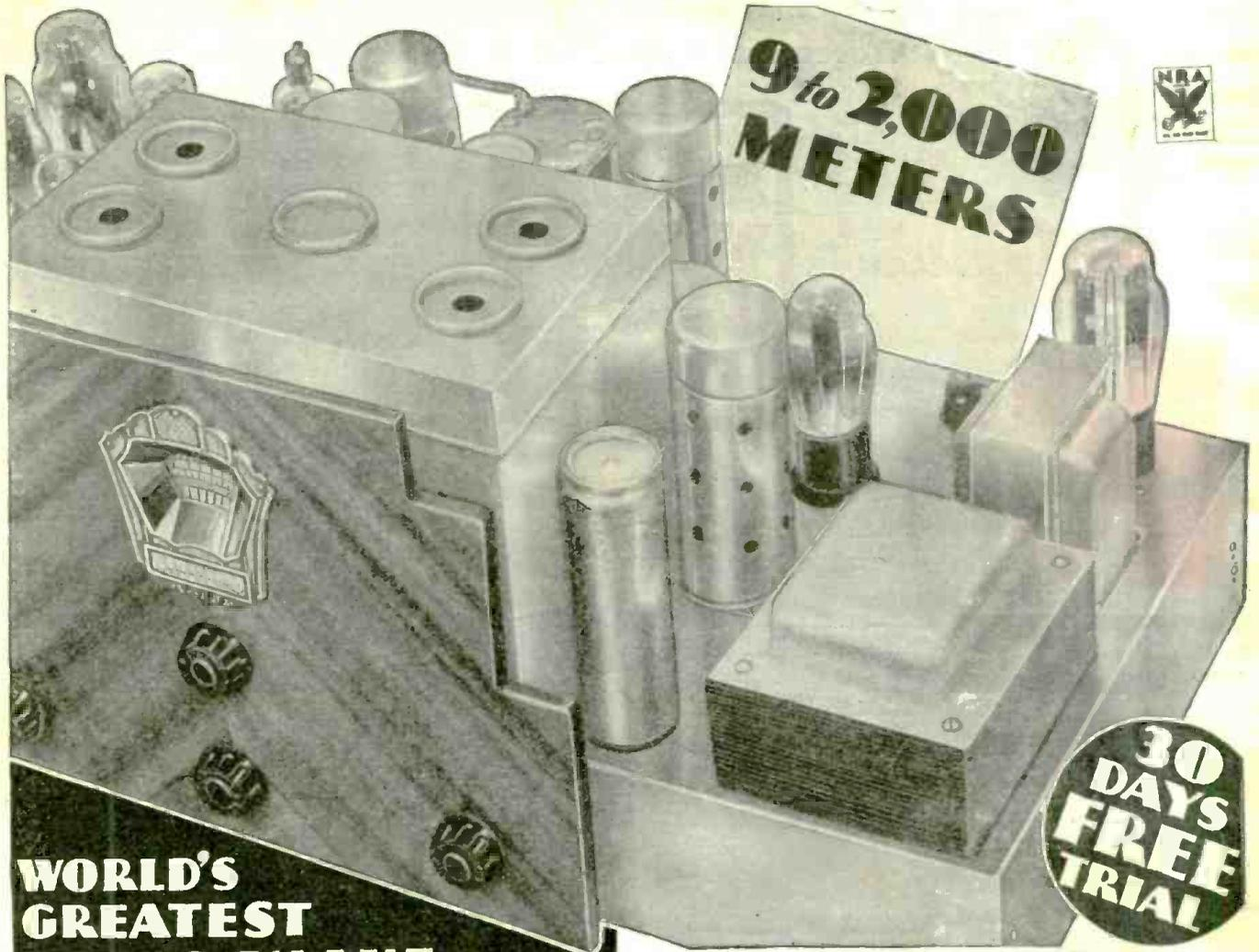

**WORLD'S
GREATEST
RADIO VALUE ...**

\$49.50
*with New
Deluxe
Auditorium Type
SPEAKER*

Deal Direct with Laboratories

**SAVE
UP TO 50%**

Get a bigger, better, more powerful, clearer-toned radio—at a positive saving of from 30% to 50%. Increasing costs are sure to result in higher radio prices soon. Buy before the big advance.... NOW, while you can take advantage of the tremendous values Midwest offers you. Try any Midwest Radio for 30 days—FREE—before you decide. As little as \$5.00 puts a set in your home. Satisfaction guaranteed or money back! Just sign and mail coupon—or send name and address on postcard.

Midwest guarantees your satisfaction by permitting you to try any Midwest set—right in your own home—for 30 days FREE trial. Thousands upon thousands of delighted Midwest owners all over the U. S. and in many foreign countries are daily enjoying the world's finest radio programs because of Midwest's revolutionary policy of selling direct from the laboratory at rock-bottom prices—and on easy terms. But don't judge quality by price. Even though we offer unbelievably low prices, Midwest Radios are of the very highest quality and positively guaranteed.

**Terms
AS LOW AS
\$5.00
DOWN**

When you buy from Midwest, you deal with one of the old-established, pioneer radio builders who have been selling quality sets all over the world for almost fourteen years. Mail the coupon or write us a postal for new 1934 catalog, easy terms and low laboratory prices.

**Get All the Facts
NOW!**

**RUSH THIS COUPON FOR
AMAZING 30-DAY FREE TRIAL
OFFER AND NEW 1934 CATALOG**

Midwest Radio Corp.—
Dept. 284,
Cincinnati, Ohio.

Without obligation on my part send me your new FREE 1934 catalog, and complete details of your liberal 30-day FREE trial offer. This is NOT an order.

Name _____

Address _____

City _____

State _____

**AGENTS! Make Easy Extra Money.
Check Here For Details ().**

DEPT. 284 — CINCINNATI, OHIO, U. S. A.
Established 1920 Cable Address Miraco. ABC 5th. Edition

IN THIS ISSUE: PROMINENT SHORT-WAVE AUTHORS

Leutz • Jones • Worcester • Denton • Egert • Victor • Shuart



HUGO GERNSBACK
Editor

H. WINFIELD SECOR
Managing Editor

Contents for October, 1933

| | |
|--|-----|
| Editorial—Short-Wave Scouting, by Hugo Gernsback..... | 327 |
| S-W Receivers That Go To Sea, by C. R. Leutz..... | 328 |
| A Pocket-Sized Short-Wave Receiver by James B. Armstrong | 329 |
| The Propagation Of 3 To 8 Meter Waves—Results of Tests With U.S.W. Transmitter Atop the Empire State Building, by L. F. Jones, R. C. A. Victor Co..... | 330 |
| The "53" 1-Tube Twinplex, by J. A. Worcester, Jr..... | 332 |
| The REX Portable Superhet S-W Receiver, by C. E. Denton and H. W. Secor..... | 334 |
| Portable 5 and 10 Meter Transmitter-Receiver, by L. L. Hotsenpiller | 336 |
| A Novel S-W Converter, by R. M. Legate..... | 337 |
| Behold the MINIDYNE!—A One-Tube Receiver That Uses No Aerial Or Ground, by Samuel S. Egert and Samuel Bagno..... | 338 |
| Building a Power-Amplifier For The Beginner's Transmitter—No. 2 of a series on "Amateur Transmitters." by Leonard Victor, W2DHN..... | 340 |
| How To Calibrate The MONITOR..... | 342 |
| The "RT" Beginner's Transmitter, by George W. Shuart, W2AMN-W2CBC..... | 343 |
| The Evolution of Ultra Short Waves, by C. C. Whitehead | 344 |
| World-Wide Short-Wave Review, edited by C. W. Palmer | 346 |
| Letters From S-W Fans..... | 348 |
| 9-Tube Superheterodyne Has Coil Switch, by M. S. Miller | 349 |
| SHORT-WAVE LEAGUE—Some "Hot" Opinions From Our Readers | 350 |
| \$5.00 For Best S-W Kink Monthly..... | 351 |
| SHORT-WAVE STATIONS OF THE WORLD—Up-To-Date List, Edited by M. Harvey Gernsback..... | 352 |
| Short-Wave QUESTION BOX..... | 356 |
| "When To Listen In," by M. Harvey Gernsback..... | 355 |
| Amateurs Who Made Good..... | 372 |

FEATURES IN NEXT ISSUE

The 2-Tube Pentaflex—a remarkable receiver, in which 2 tubes do the work of 4, by J. A. Worcester, Jr.
 Short-Wave Antennas—How To Erect The Most Efficient Form Of Aerials, With The Latest Transposition Lead-Ins.
 "The Wyeth All-Wave 6," by C. A. Wyeth.
 How to Build a Good 10-Meter Receiver, by George Shuart.
 Amateur Transmitters—Adding A Modulator For 160 Meter Phone, by Leonard Victor, W2DHN.
 Latest European Short-Wave Circuits, by C. W. Palmer.



Certified Circuits

● **SHORT WAVE CRAFT** goes to a large expense in verifying new circuits published in this magazine. Whenever you see the seal shown here in connection with any of the sets published in this and future issues of **SHORT**

WAVE CRAFT, this will be your guarantee that this set has been tested in our laboratories, as well as privately, in different parts of the country to make sure that the circuit and selected parts are right. Only "Constructional-Experimental" circuits are certified by us.

When you see our certificate seal on any set described you need not hesitate in spending money for parts, because you are assured in advance that the set and circuit are bona fide and that this magazine stands behind it.

SHORT WAVE CRAFT is the only magazine that thus certifies circuits and sets.

OUR COVER

● **THE** cover illustration this month shows the **MINIDYNE**—the very latest 1-tube short-wave receiver, which requires no aerial or ground. This set has picked up short-wave signals over 100 miles away—a quite remarkable performance. Full constructional details are given on page 338

COPYRIGHT, 1933, BY H. GERNSBACK

Published by **POPULAR BOOK CORPORATION**

HUGO GERNSBACK, President - - **H. W. SECOR**, Vice-President
EMIL GROSSMAN - - - - - Director of Advertising
 Chicago Adv. Office - - - **L. F. McCLURE**, 737 No. Michigan Blvd.
 Publication Office - - - 404 N. Wesley Avenue, Mount Morris, Ill.
 Editorial and General Offices - - 96-98 Park Place, New York, N. Y.
 London Agent: **HACHETTE & CIE.**, 16-17 King William St., Charing Cross, W.C.2

Paris Agent: **HACHETTE & CIE.**, 111 Rue Reaumur
 Australian Agents: **McGILL'S AGENCY**, 179 Elizabeth St., Melbourne

SHORT-WAVE CRAFT—Monthly. Entered as second class matter May 7, 1930, at the post office at Mount Morris, Illinois, under the act of March 3, 1879. Trademarks and copyrights by permission of H. Gernsback, 98 Park Place, N. Y. C. Text and illustrations of this magazine are copyrighted and must not be reproduced without permission. **SHORT WAVE CRAFT** is published on the 5th of every month. Twelve numbers per year. Subscription price is \$2.50 a year in the United States and possessions. Canada and foreign countries, \$3.00 a year. Single copies 25c. Address all contributions for publication to Editor, **SHORT WAVE CRAFT**, 96-98 Park Place, New York, N. Y. Publishers are not responsible for lost manuscripts. Contributions cannot be returned unless authors remit full postage. **SHORT WAVE CRAFT** is for sale at all principal newsstands in the United States and Canada. European agents: Brentano's, London and Paris. Printed in U. S. A. Make all subscription checks payable to Popular Book Corporation.

OPPORTUNITIES *are many* for the Radio Trained Man

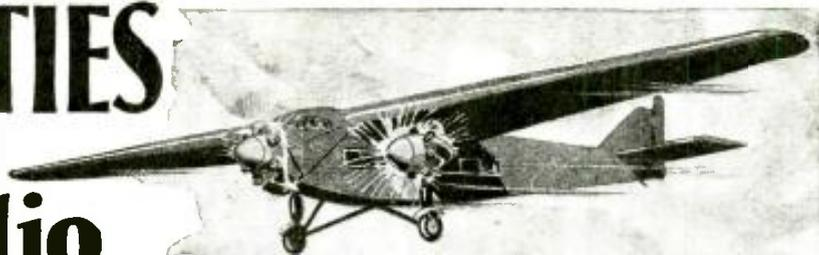

Don't spend your life slaving away in some dull, hopeless job! Don't be satisfied to work for a mere \$20 or \$30 a week. Let me show you how to get your start in Radio—the fastest-growing, biggest money-making game on earth.

Jobs Leading to Salaries of \$50 a Week and Up

Prepare for jobs as Designer, Inspector and Tester—as Radio Salesman and in Service and Installation Work—as Operator or Manager of a Broadcasting Station—as Wireless Operator on a Ship or Airplane, or in Talking Picture or Sound Work—HUNDREDS OF OPPORTUNITIES for a real future in Radio!

Ten Weeks of Shop Training

Pay Your Tuition After Graduation

We don't teach by book study. We train you on a great outlay of Radio, Television and Sound equipment—on scores of modern Radio Receivers, huge Broadcasting equipment, the very latest and newest Television apparatus, Talking Picture and Sound Reproduction equipment, Code Practice equipment, etc. You don't need advanced education or previous experience. We give you—RIGHT HERE IN THE COYNE SHOPS—the actual practice and experience you'll need for your start in this great field. And because we cut out all useless theory and only give that which is necessary you get a practical training in 10 weeks.



TELEVISION *and* TALKING PICTURES

And Television is already here! Soon there'll be a demand for THOUSANDS of TELEVISION EXPERTS! The man who learns Television now can have a great future in this great new field. Get in on the ground-floor of this amazing new Radio development! Come to COYNE and learn Television on the very latest, newest Television equipment. Talking Picture and Public Address Systems offer opportunities to the Trained Radio Man. Here is a great new Radio field just beginning to grow! Prepare NOW for these wonderful opportunities! Learn Radio Sound Work at COYNE on actual Talking Picture and Sound Reproduction equipment.

PAY FOR YOUR TRAINING After You Graduate

I am making an offer that no other school has dared to do. I'll take you here in my shops and give you this training and you pay your tuition after you have graduated. Two months after you complete your course you make your first payment, and then you have ten months to complete your payments. There are no strings to this offer. I know a lot of honest fellows haven't got a lot of money these days, but still want to prepare themselves for a real job so they won't have to worry about hard times or lay offs.

I've got enough confidence in these fellows and in my training to give them the training they need and pay me back after they have their training.

If you who read this advertisement are really interested in your future here is the chance of a life time. Mail the coupon today and I'll give you all the facts.

ALL PRACTICAL WORK At COYNE in Chicago

ALL ACTUAL, PRACTICAL WORK. You build radio sets, install and service them. You actually operate great Broadcasting equipment. You construct Television Receiving Sets and actually transmit your own Television programs over our modern Television equipment. You work on real Talking Picture machines and Sound equipment. You learn Wireless Operating on actual Code Practice apparatus. We

don't waste time on useless theory. We give you the practical training you'll need—in 10 short, pleasant weeks.

MANY EARN WHILE LEARNING

You get Free Employment Service for Life. And don't let lack of money stop you. Many of our students make all or a good part of their living expenses while going to school and if you should need this help just write to me. Coyne is 33 years old. Coyne Training is tested—proven beyond all doubt. You can find out everything absolutely free. Just mail coupon for my big free book!

H. C. Lewis, Pres. RADIO DIVISION Founded 1899

COYNE Electrical School

500 S. Paulina St., Dept. 73-2K, Chicago, Ill.

Mail Coupon Today for All the Facts

H. C. LEWIS, President

Radio Division, Coyne Electrical School
500 S. Paulina St., Dept. 73-2K, Chicago, Ill.

Dear Mr. Lewis:— Send me your Big Free Radio Book, and all details of your Special Offer.

Name.....

Address.....

City.....State.....

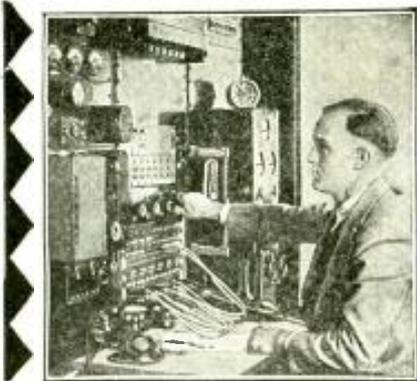

Broadcasting Stations employ trained men continually for jobs paying up to \$5,000 a year.



Police Departments are finding Radio a great aid in their work. Many good jobs have been made in this new field.



Spare-time set servicing pays many N.R.I. men \$5, \$10, \$15 a week extra. Full-time men make as much as \$40, \$60, \$75 a week.

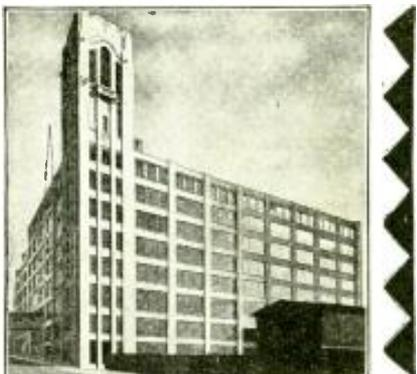

Radio Factories—Employ testers, inspectors, foremen, engineers, service men, for jobs paying up to \$7,500 a year.



Television—the coming field of many great opportunities—is covered by my course.

I WILL TRAIN YOU AT HOME

Many Make \$40, \$60, \$75 a Week in Radio -- the Field With a Future

My book, "Rich Rewards in Radio," gives you full information on the opportunities in Radio and explains how I can train you quickly to become a Radio Expert through my practical Home-Study training. It is free. Clip and mail the coupon NOW. Radio's amazing growth has made hundreds of fine jobs which pay \$40, \$60 and \$75 a week. Many of these jobs may quickly lead to salaries as high as \$100, \$125 and \$150 a week.

Radio—the Field With a Future

Ever so often a new business is started in this country. You have seen how the men and young men who got into the automobile, motion picture and other industries when they were started had the first chance at the big jobs—the \$5,000, \$10,000 and \$15,000 a year jobs. Radio offers the same chance that made men rich in those businesses. It has already made many men independent and will make many more wealthy in the future. You will be kicking yourself if you pass up this once-in-a-lifetime opportunity for financial independence.

Many Radio Experts Make \$40, \$60, \$75 a Week

In the short space of a few years 300,000 Radio jobs have been created, and thousands more will be made by its future development. Men with the right training—the kind of training I will give you in the N.R.I. Course—have stepped into Radio at 2 and 3 times their former salaries. Experienced service men as well as beginners praise N.R.I. training for what it has done for them.

Many Make \$5, \$10, \$15 a Week Extra In Spare Time Almost At Once

My Course is world-famous as the one "that pays for itself." The day you enroll I send you instructions, which you should master quickly, for doing 28 Radio jobs common in most every neighborhood. Throughout your Course I will show you how to do other repair and service jobs on the side for extra money. I will not only show you how to do the jobs but how to get them. I'll give you the plans and ideas that have made \$200 to \$1,000 a year for hundreds of fellows. G. W. Page, 110 Raleigh Apts., Nashville, Tenn., writes: "I made \$935 in my spare time while taking your Course." My book, "Rich Rewards in Radio," gives many letters from students who earned four, five and six times their tuition fees before they graduated.

Get Ready Now for Jobs Like These

Broadcasting stations use engineers, operators, station managers and pay up to \$5,000 a year. Radio manufacturers employ testers, inspectors, foremen, engineers, service men, buyers and managers for jobs paying up to \$7,500 a year. Radio dealers and jobbers (there are over 35,000) employ service men, salesmen, buyers, managers and pay up to \$100 a week. There are hundreds of opportunities for you to have a spare-time or full-time Radio business of your own—to be your own boss. I'll show you how to start your own business with practically no capital—how to do it on money made in spare time while learning. My book tells you of other opportunities. Be sure to get it at once. Just clip and mail the coupon.

I HAVE STARTED MANY IN RADIO AT 2 AND 3 TIMES



**\$400.00
Each
Month**

"I spent fifteen years as traveling salesman and was making good money but could see the opportunities in Radio. Believe me, I am not sorry, for I have made more money than ever before. I have made more than \$400 each month and it really was your course that brought me to this. I can't say too much for N.R.I."—J. G. Dahlstead, Radio Sta. KYA, San Francisco, Cal.



**\$800.00
In Spare
Time**

"Money could not pay for what I got out of your course. I did not know a single thing about Radio before I enrolled, but I have made \$800 in my spare time, although my work keeps me away from home from 6:00 A.M. to 7:00 P.M. Every word I ever read about your course I have found true."—Milton I. Leiby, Jr., Tipton, Pennsylvania.



**Chief
Engineer
Station WOS**

"I have a nice position and am getting a good salary as Chief Engineer of Radio Station WOS. Before entering Radio, my salary was barely \$1,000.00 a year. It is now \$2,100.00 a year. Before entering Radio, my work was, more or less, a drudgery—it is now a pleasure. All of this is the result of the N.R.I. training and study. You got me my first important position."—H. H. Lance, Radio Station WOS, Jefferson City, Missouri.

TO BE A RADIO EXPERT



Act Now --- Mail Coupon Below for Free Book of Facts and Proof

You Can Learn at Home in Your Spare Time to be a Radio Expert

Hold your job. There is no need for you to leave home. I will train you quickly and inexpensively during your spare time. You don't have to be a high school or college graduate. My Course is written in a clear, interesting style that most anyone can grasp. I give you practical experience under my 50-50 method of training—one-half from lesson books and one-half from practical experiments with equipment given without extra charge. This unique and unequalled method has been called one of the greatest developments in correspondence Radio training. N.R.I. pioneered and developed it. It makes learning at home easy, fascinating, practical.

Learn the Secrets of Short Wave, Television, Talking Pictures, Set Servicing, Broadcasting

I'll give you more training than you need to get a job—I'll give you your choice, and not charge you extra either, of my Advanced Courses on these subjects—(1) Television, (2) Set Servicing and Merchandising, (3) Sound Pictures and Public Address Systems, (4) Broadcasting, Commercial and Ship Radio Stations, (5) Aircraft Radio. Advanced specialized training like this gives you a decided advantage.

Your Money Back if You are Not Satisfied

I will give you an agreement in writing, legal and binding upon this Institute, to refund every penny of your money upon completing my Course if you are not satisfied with my Lessons and Instruction Service. The resources of the National Radio Institute, Pioneer and World's Largest Home-Study Radio School, stand behind this agreement.

Find Out What Radio Offers. Get My Book

One copy of my valuable 64-page book, "Rich Rewards in Radio," is free to any resident of the U. S. and Canada over 15 years old. It has started hundreds of men and young men on the road to better jobs and a bright future. It has shown hundreds of men who were in blind-alley jobs, how to get into easier, more fascinating, better-paying work. It tells you where the good Radio jobs are, what they pay, how you can quickly and easily fit yourself to be a Radio Expert. The Coupon will bring you a copy free. Send it at once. Your request does not obligate you in any way. Mail coupon in envelope or paste on post card. ACT NOW.

J. E. SMITH, President

Dept. 3KB3, National Radio Institute
Washington, D. C.

Special FREE Offer



Act now and receive in addition to my big free book, "Rich Rewards in Radio," this Service Manual on D. C., A. C. and Battery Operated sets. Only my students could have this book in the past. Now readers of this magazine who mail the coupon will receive it free. Overcoming hum, noises of all kinds, fading signals, broad tuning, howls and oscillations, poor distance reception, distorted or muffled signals, poor Audio and Radio Frequency amplification and other vital service information is contained in it. Get a free copy by mailing the coupon below. ACT NOW.

SPECIAL Radio Equipment for Broad Practical Experience Given Without Extra Charge



My Course is not all theory. I'll show you how to use my special Radio equipment for conducting experiments and building circuits which illustrate important principles used in such well-known sets as Westinghouse, General Electric, Philco, R. C. A., Victor, Majestic and others. You work out with your own hands many of the things you read in our lesson books. This 50-50 method of training makes learning at home easy, interesting, fascinating, intensely practical.

Clip and mail NOW for FREE INFORMATION

J. E. SMITH, President
National Radio Institute, Dept. 3KB3
Washington, D. C.

Dear Mr. Smith: Please send me your sample lesson "Trouble Shooting in D.C., A.C. and Battery Sets" and your book, "Rich Rewards in Radio," which points out the opportunities for spare-time and full-time jobs in Radio and your famous 50-50 method of training men to become Radio Experts through home study. I understand that this places me under no obligation.

(Please print plainly)

Name..... Age.....

Address.....

City..... State.....

"M"

FORMER PAY



Experienced Radio Man Praises N.R.I. Course

"Before taking your course, I had worked at Radio for over seven years, doing quite a bit of servicing, but I realized that I was in need of better training. From the first lesson on I began to understand points that had had me wondering. The course has taught me what I could not have learned otherwise and I would not take many times the price it has cost me, for the knowledge I have gained. In a period of nine months, I have made at least \$3,500."—C. J. Stegner, 28 So. Sandusky St., Delaware, Ohio.



COME TO THE

SHOW OF WONDERS

20TH CENTURY THRILLS!! **MADISON SQUARE GARDEN**
SEPTEMBER 20 TO 30

NATIONAL RADIO AND ELECTRICAL EXPOSITION

SPONSORED BY THE ELECTRICAL ASSOCIATION OF NEW YORK, INC.

NOW YOU can SEE the electrical marvels you've been reading about . . . How New York police catch crooks with radio . . . Electric "eye" that closes doors, opens windows, turns on lights, etc. . . . Television in action . . . Radio stars broadcasting national programs . . . Talkie picture stars in person, in action . . . Electric "fun room" for boys and girls . . . Air cleaned, cooled, humidified or de-humidified, and circulated by electricity . . . New electric work-savers, entertainers and health promoters in an All-American all-electric home . . . washers, ironers, lamps, vacuum cleaners, the new refrigerators, clocks, radios, cookers, ranges, toasters, oil burners, air conditioners, sewing

machines, home talkies . . . the leading makes actually demonstrated under one roof . . . New short-wave receiver picking up world-wide broadcasts . . . Try-outs for coming radio talent.

• • •

These and hundreds of other fascinating exhibits illustrate the swift progress of the Electrical Age and what it means in your home, office or factory.

New York's first opportunity in four years to see and compare everything electrical in one place on one visit. Something going on every minute. Come, and bring your family. Madison Square Band of Syncopaters—day and evening.

**Exposition open every day from 11:00 to 11:00. Admission
only 25c. Madison Square Garden, 8th Avenue and
50th Street, New York City**



Short-Wave Scouting

An Editorial By HUGO GERNSBACK

● STRANGE as it may seem, there are two kinds of short-wave radio listening, which idea does not seem to be recognized by many listeners. The first class comprises short-wave listening of the so-called "obvious" that is, high-power stations, which almost anyone can get with a one- or two-tube set. The reason for this is that the stations in question are so powerful that it does not take much trouble nor patience to pull them in. Indeed, these stations can be heard day in and day out, practically the entire year, when they are on the air. Such stations are, for instance, in the United States: the high-power stations of the General Electric Company at Schenectady, W2XAF; Westinghouse Electric, Pittsburgh, W8XX; National Broadcasting Co. at Bound Brook, W3XAL, and a number of others. Outside of the United States, the stations received easily are Daventry, England, GSG; Madrid, Spain, EAQ; Sydney, Australia, VK2ME; Melbourne, Australia, VK3ME; the Pontoise, France, stations; the German, Koenigswusterhausen station DJA, and a number of others familiar to all short-wave listeners for easy reception.

The other class comprises stations not so easily logged, and where time and patience is required to hear them at all. As a rule, they cannot be logged with a two-tube set, and it takes a multitube set, from four tubes and upwards, to the superheterodyne style of seven tubes and more, to bring in such elusive stations. The reason for this is, of course, that the power behind these stations is comparatively small, and amounts to only a small fraction of that of the "easy" stations.

After the short-wave beginner has listened to the *easy* stations for a while, this soon palls on him and he will want to reach out for new air adventures. To do so, he gets a more powerful set, and this he either builds or buys a *factory-made* receiver. He is now ready to log the "difficult" kind of stations, and he will never hear them regularly nor very often, and that is where the sport of short-wave reception comes in, because anything that comes too easy in life usually is not worthwhile. The studious type of short-wave listener who goes after the hard ones, of course, keeps a "log" when he hears the stations, listens carefully for their call letters, when received, and other interesting data. In this case, the short-wave listener be-

comes a *Professional Short-Wave Scout*. With some 8500 commercial short-wave radio stations scattered all over the globe, it becomes a matter of pride with most listeners to see how many of these stations can actually be "logged."

And it is here that I would like to make a personal appeal to all professional *short-wave scouts*. It is almost impossible to obtain an accurate list of short-wave stations of the world. The publishers of SHORT WAVE CRAFT recently attempted this by putting out the OFFICIAL SHORT WAVE LOG AND CALL BOOK, in which some 8500 commercial stations are listed. The professional listener, however, knows that stations are apt to change over night. New stations spring up unannounced, transmitter locations are changed, power is changed, all without notification to anyone.

While the Federal Radio Commission lists the stations in the United States, foreign countries rarely do so, and sometimes months pass before a new station or a change made in either wavelength, call letter or equipment of such a station breaks into print. For that reason, I request that professional listeners send in calls which they have logged and which are not usually found in either SHORT WAVE CRAFT or the OFFICIAL SHORT WAVE LOG AND CALL BOOK.

This is merely asked in a spirit of cooperation, because information obtained in this manner can be, as a rule, quickly verified, and then corrections or additions can be printed promptly. The same is, of course, the case of stations which are not listed at all in either SHORT WAVE CRAFT or the OFFICIAL SHORT WAVE LOG AND CALL BOOK.

If a few thousand readers would report such changes, additions, etc., regularly to our headquarters, it would certainly help all, and would benefit the entire short-wave radio fraternity.

In return for the efforts expended by our readers, SHORT WAVE CRAFT will, in an early issue, print the names of those who consistently report calls heard to the columns of our publications. In a forthcoming issue of this publication there will be described a handsome cup, which will be donated every three months by SHORT WAVE CRAFT to those *Short Wave Scouts* who help to further the cause of short waves.

Watch for the announcement!

TO OUR READERS

THE EDITOR of SHORT WAVE CRAFT asks for special cooperation by the readers of SHORT WAVE CRAFT. He also inaugurates a new movement to be known hereafter as "Short Wave Scouts."

SHORT-WAVE CRAFT IS PUBLISHED ON THE 5th OF EVERY MONTH

This is the October, 1933, Issue—Vol. IV, No. 6. The next Issue Comes out October 5th

S-W Receivers That Go To Sea

By C. R. LEUTZ*

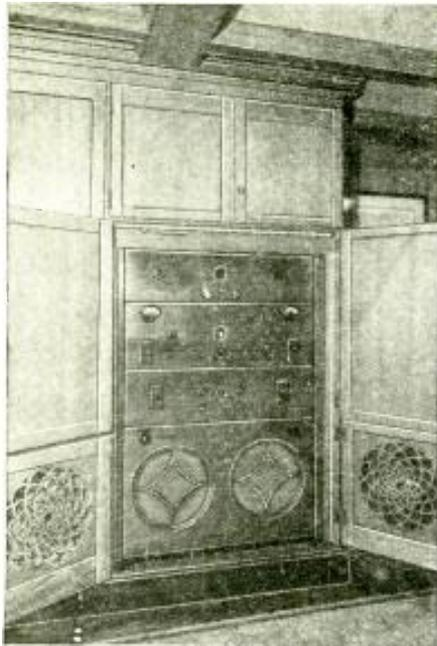

Front view of the 3-section "triple range" receiver used on the yacht "Aras"; it tunes in short, broadcast, and long waves.

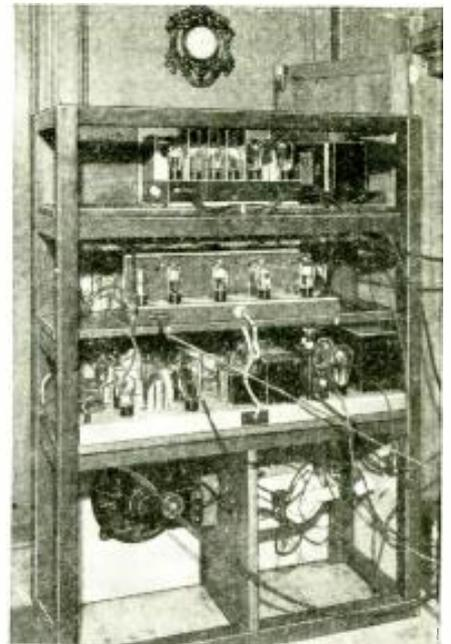

Rear view of the triple wavelength range receiver designed and built by Mr. Leutz for the 243 foot yacht, "Aras."

In the accompanying article Mr. Leutz, eminent short-wave apparatus designer, gives us some very interesting information on "Pro" type short-wave receivers which have been built for use on large private yachts. Every short-wave "fan" will devour the details of the advanced design exemplified in these "pro" sets.

● THE successful design of broadcast receiving equipment for yacht installations is a problem all by itself and is not generally understood. With the craft at dock and near broadcast transmitters, any average broadcast receiver works fairly well. With the yacht under way, it is another matter and each installation must be given individual consideration and attention to get satisfactory results.

The yacht "ARAS," a 243-foot modern Diesel craft with a crew of 30 men and the yacht "MIGRANT," 223 feet long, with a crew of 33, the largest auxiliary schooner in the world, both originally had special radio equipment installed for entertainment purposes. This apparatus was entirely separate from the regular commercial radio transmitters and receivers which

are aboard for world-wide communication purposes. The original broadcast receivers installed were quite elaborate but not at all satisfactory except over a very limited range.

The writer was assigned the work of designing and constructing broadcast receiving equipment for these two yachts, a strict custom job, results to be guaranteed. Both installations worked out exceedingly satisfactory and were promptly accepted.

A description of these sets together with the problems involved follows.

Yacht "Aras" Installation

All large yachts have electric generating plants delivering direct current. To design a powerful radio re-

ceiver requires an alternating current source. A motor-generator or rotary converter must be provided to change the direct current to alternating current which in turn feeds the radio receiver and power amplifiers.

The electric generating plants are equipped with a storage battery providing a source of current when the generator is shut down or out of commission. If the storage battery is a lead cell type, the D.C. voltage remains fairly constant. When Edison storage batteries are used, the battery voltage varies from 110 to 140 volts and a regulating device must be provided to limit the voltage to 110 as applied to the rotary converter. Furthermore, this rotary converter must

(Continued on page 359)

*Director, Eastern Research Laboratories.

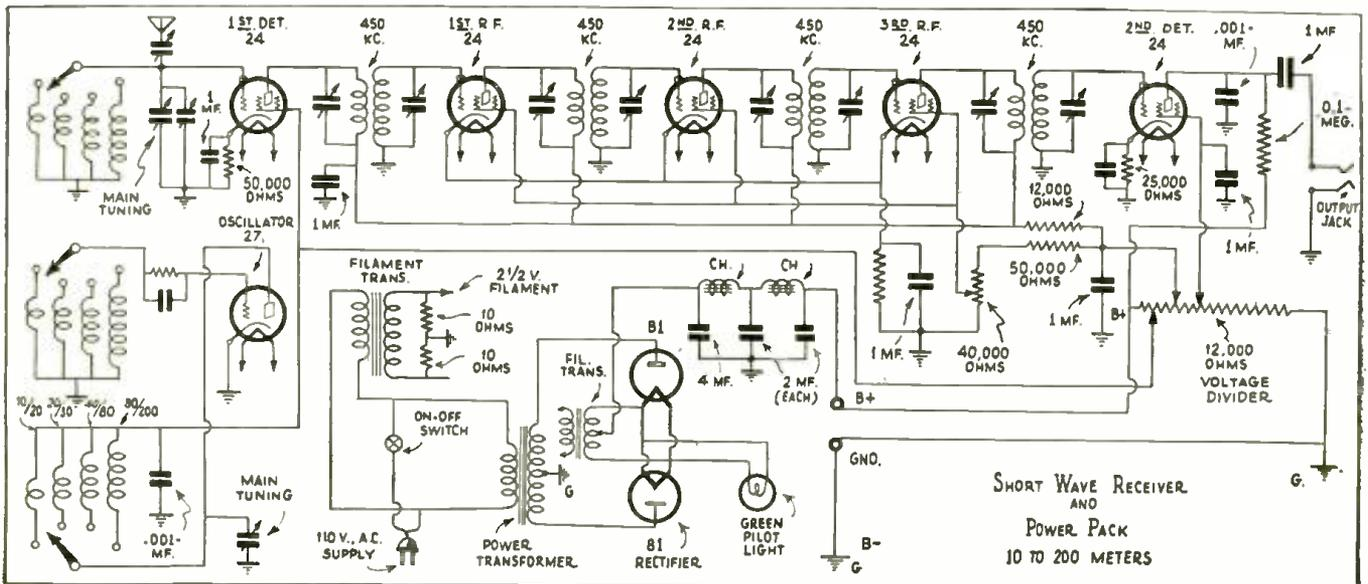

Wiring diagram of the short-wave receiving set installed on the yacht, "Aras"

A Pocket-Sized Short-Wave Receiver

By JAMES B. ARMSTRONG

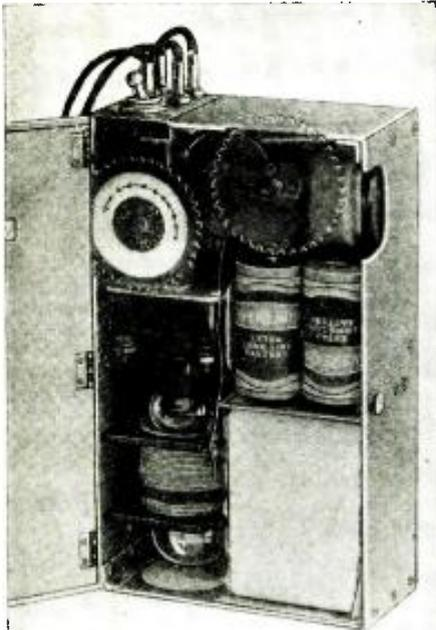

Note the neat appearance of this extremely compact 1-tube S-W receiver built by Mr. Armstrong. The flat celluloid dials project through slots in the case.

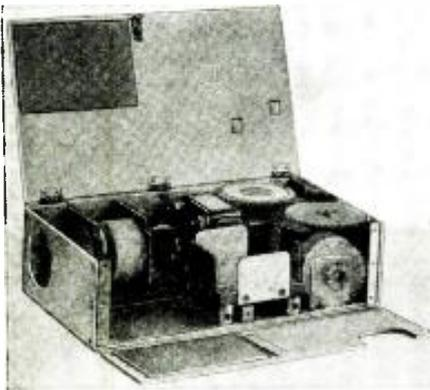

Another view of Mr. Armstrong's "pocket-size" receiver, which is built into a metal case; but a cigar box may be used instead.

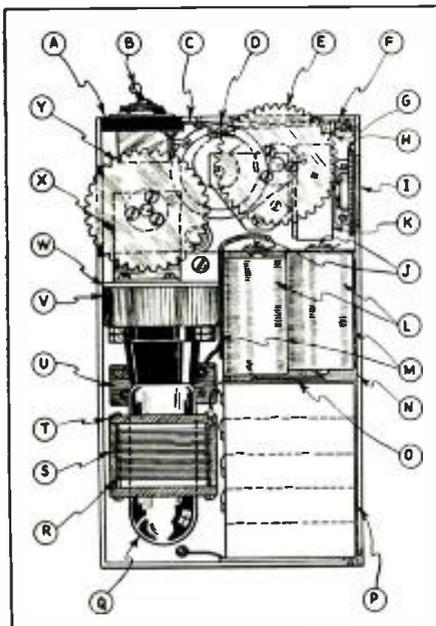

This drawing shows the general assembly of the parts in the "pocket-size" receiver.

A number of novel features are incorporated in this pocket-size, 1-tube short-wave receiver. It can be built in a small metal case or in a cigar box if so desired. Both the "A" and "B" batteries are enclosed within the case.

● THIS miniature receiver was designed to cover the wavelength band of 75-85 meters and contains all necessary apparatus, with the exception of headphones, to bring in stations on both code and phone bands over a distance of one or two thousand miles. All that is necessary to put the set into operation is to insert the phone, aerial and ground cord tips into their respective jacks, clip the aerial and ground cord to a small aerial and a ground, and turn on the tube filament. A bed spring is very satisfactory as an aerial, while a ground can be secured on the waterpipe. Out-of-doors, a few feet of wire thrown up into a tree provides a satisfactory aerial, and a metal rod pushed into the earth as a ground.

The box which contains the set is made of 1/16" aluminum and measures 2" by 4" by 7" outside dimensions. It is fastened together by 2-56 flat-head brass screws and 1/32" brass angles, the two four-inch sides being bent up from the base, making a "U"-shaped base upon which to mount the instruments. The lid of the box is a piece of aluminum 1/16" by 4" by 7" and is fastened to the box by means of 1/4" brass hinges secured with 2-56 flat-head brass machine screws. On the right side of the box is a brass snap-catch with push button to operate for opening the box to inspect the interior or to replace batteries.

A bakelite panel "A" for mounting the phone, aerial and ground tip jacks and filament tumbler switch "B", is set into the upper left-hand corner of the box and forms part of the upper side. It measures 3/16" by 1" by 2", and is screwed to the left side and to the base. It is also secured to the upper side of the box by means of a brass "Z"-shaped piece "C", and 2-56 screws. No particular dimensions will be

given for mounting the component parts of the set, as they will be found to fit in the positions shown in the sketch.

Tube and Tube Socket

The tube socket should be mounted on edge and screwed to an aluminum angle on the bottom of the socket, the angle being screwed to the bottom or rear side of the box. If, now a 1 1/4" hole is cut in the lower side of the box opposite the tube socket, the tube can be inserted through the box into the tube socket or removed at any time.

The tube used must be a 30 or one of similar physical dimensions in order to slip through the hole in the side of the box and the tuner coil form. The type 30 tube was also used on account of its low filament current consumption and voltage and the fact that it will operate efficiently on 22 1/2 volts of "B" battery.

The throttle condenser for controlling regeneration and oscillation (for "CW") is a 13-plate (.00005 mf. capacity) midget. It is secured to the tube socket bracket, by means of another "L" shaped bracket, and is rotated or controlled by means of a toothed celluloid disc 1/16" thick and 1 3/8" in diameter. This control disc is screwed to a 5/8" brass bushing fitted with a set-screw to hold the assembly securely onto the condenser shaft.

Tuning Inductance

The tuner consists of three windings on a cardboard tube 1 3/8" long cut with a razor blade from an insulating tube from a No. 950 battery cell. The secondary or grid winding consists of 30 turns of No. 28 D. C. C. copper
(Continued on page 358)

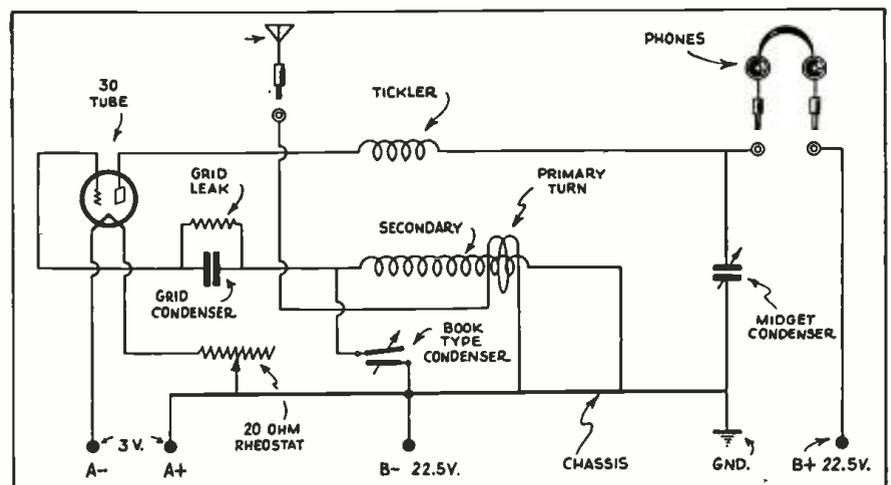

Wiring diagram for the 1-tube "pocket" short-wave receiver. A regular midget rotary condenser of .00014 or .0001 mf. and standard "plug-in" coils, may be used instead of the book-type condenser used by the author.

The PROPAGATION of 3 to

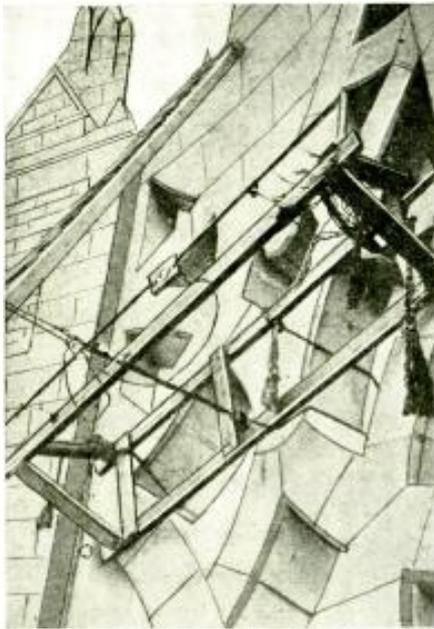

Fig. 1. Horizontal Half-wave Antenna, as tried out on top of Empire State Building.

● ULTRA-SHORT waves are being widely applied experimentally to radio communication and broadcasting, and already have limited commercial application. Undoubtedly the commercial utilization of these waves will increase rapidly. For the intelligent application of any band in the radio frequency spectrum, the propagation characteristics of that band must be known. To learn such characteristics, the RCA Victor Company, working jointly with RCA Communications, Inc., and the National Broadcasting Company, have investigated and are investigating the characteristics of wavelengths below ten meters. Others have experimented extensively on the same subject.

Wavelengths higher than seven or eight meters are occasionally reflected from the Heaviside layer. The present paper deals only with the propagation characteristics of wavelengths between about three and eight meters. Probably wavelengths of eight to twelve meters have similar propagation characteristics to the shorter ones, except that sky wave reflections may be experienced during certain years of the eleven-year sun cycle, especially in the middle of the day. This may not prevent these waves from being widely used for some types of local communication.

Mr. R. D. Kell, the transmitter power was increased to one kilowatt, and more extensive observations were made in the Camden-Philadelphia territory.

Activities were then transferred to New York, where the preponderance of steel buildings, the remote locations of the suburbs, and the large amount of automobile ignition interference were expected to make most conditions of reception as severe as will be found in any American city. A fifty-watt transmitter was installed on the RCA Building at 51st Street and Lexington Avenue, the antenna being 650 feet above street level.

A vertical half-wave antenna was used for the majority of the observations and transmission was conducted on 3.5, 5, 6.5, and 8.5 meters. Observations were made in all directions inside and outside of buildings, and at distances up to thirty miles. It seemed advisable before making many observations to compare several antenna locations on the roof so that the optimum might be used for propagation measurement purposes. Six antenna positions were tested in the tower that constitutes the topmost portion of the RCA Building. This tower is hollow, about forty feet in height, and is made of a latticework of stone and bricks that include many openings for artistic purposes. Fig. 1 shows one of the arrangements, where the antenna was placed horizontally within the hollow tower. Fig. 2 shows the final antenna location used for the tests. Differences between horizontally and vertically polarized waves appeared of little importance, but locating the antenna high enough to be practically clear of the surrounding stone work, as shown in Fig. 2, gave an increase in field strength of several hundred per cent. Absorption in the lattice stone work was very great for antenna locations such as shown in Fig. 1.

The propagation data gained from these preliminary Camden and New York tests were later enhanced by quantitative measurements made of transmission from the Empire State Building.

Transmitting Equipment

Preliminary tests made with a portable ultra-short-wave transmitter located on the top of the Empire State

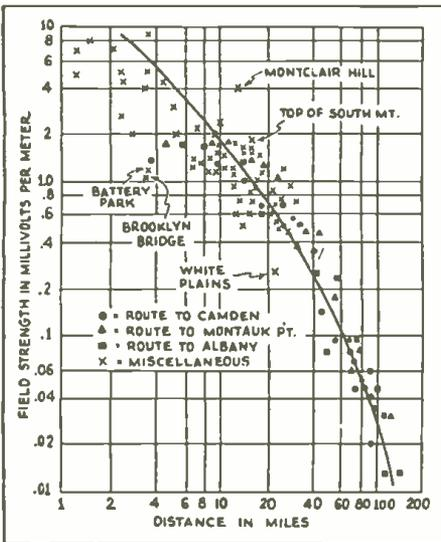

Fig. 6. Attenuations of 44 Megacycle Signal from Empire State Building.

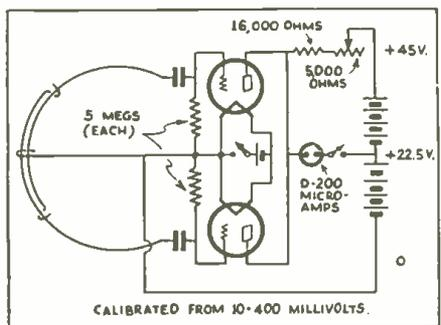

Fig. 5. Circuit Used in Low Sensitivity "Loop" Receiver.

Early Test

Early in 1930, Dr. Haigis developed low power ultra-short-wave apparatus and conducted limited propagation experiments. Since the fall of that year various transmitters operating on wavelengths down to three meters have been manufactured and sold for special purposes.

Measurements made in 1930 of the coverage of a transmitter of several hundred watts power operating on about six meters, located 120 feet above the street level in Camden, indicated that valuable broadcast services could be rendered by ultra-short-wave transmitters. Television was partly in mind in view of the impossibility of securing adequate channel widths on higher wavelengths and of eliminating the effects of sky reflections. Later, under the direction of

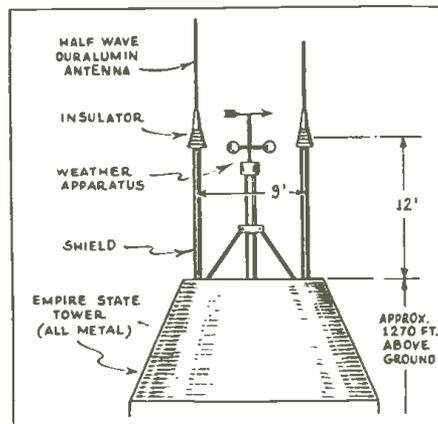

Fig. 3. General Layout of Empire State Building Antenna.

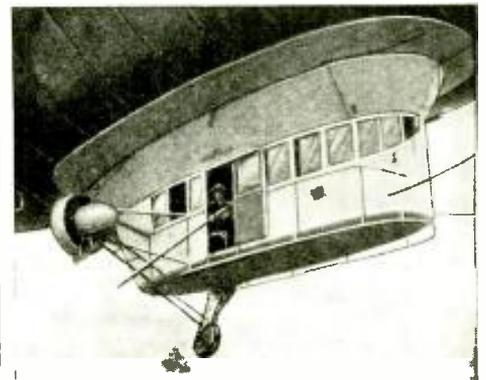

Fig. 4. Test in Dirigible, Columbia.

8 Meter Waves

By L. F. JONES, R.C.A. Victor Company

Television in every home will be with us before we realize it, and from all the present indications both the "image" and the "voice" will be transmitted on wavelengths somewhere between 3 and 8 meters. The present article is, therefore, of tremendous importance, giving as it does some of the actual measured results obtained on these low wavelengths, the majority of observations and tests having been made on television signals transmitted from the top of the Empire State Building in New York City. Signals were recorded at a distance as great as 280 miles.

building had shown the superiority of the 1300-foot altitude of this building over the 650 feet of the RCA building, and for this and other reasons space was secured on the 85th floor for the installation of television transmitters and studios. A picture transmitter operating on a frequency of forty-four megacycles (6.8 meters) with about two kilowatt output, and sound transmitter operating on 61 megacycles (4.9 meters) with an output of about one kilowatt, were installed in July of 1931. Each transmitter was coupled through a 275-foot concentric tube transmission line to its antenna. Fig. 3 shows the antennas used for the propagation measurements. Each antenna was a half wavelength long and was made of one and one quarter inch duralumin rod. The antennas were elevated above everything else, their bases being at about the same level as the top of the weather apparatus. In fact, the antennas were the highest structures above ground level ever erected anywhere. The antennas were spaced nine feet apart which rendered a reasonably small reflection effect of the one on the other.

The transmitters utilized precision quartz crystal oscillators, driving their respective power amplifiers through doubler and tripler stages. Each transmitter was modulated in its power amplifier stage, up to 100 per cent. Antenna currents as indicated by commercial thermo-couple meters were about seven amperes and five amperes on forty-four and sixty-one megacycles respectively, and are thought to indi-

cate powers of about two kilowatt and one kilowatt.

Receiving Equipment

Observations of the Empire State radiations were made by airplane, autogiro, dirigible, and automobile.

The measuring equipment used for the majority of observations consisted of a high sensitivity receiver of the superheterodyne type using detector, oscillator, three stages of six-megacycles intermediate-frequency amplification (using pentodes) and second detector. This receiver was developed and calibrated under the direction of Mr. G. L. Beers of the research division. An indicating microammeter, with bucking battery, was in the second detector plate circuit. Several stages of audio amplification followed for operating a loud speaker for the sake of convenience during certain tests. When used in an automobile the receiver was mounted on the rear seat and coupled to a half-wave vertical antenna. The receiver was calibrated by inserting a resistance of known value in the center of the half-wave receiving antenna, and by inducing therein a current of known value from a signal generator. This calibration was checked by other measurements. Although they checked reasonably closely, it is probable that considerable calibration error existed. The equipment was calibrated for field (Continued on page 373)

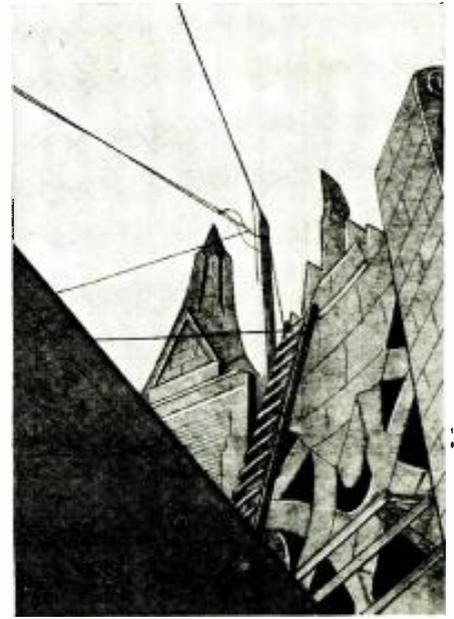

Fig. 2. Final Antenna for R. C. A. Building Test.

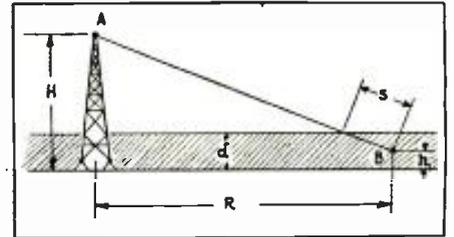

Fig. 8. Shows Graphically the Relations Existing Between Height of Transmitting Antenna, Height of Receiving Aerial, "R" the Distance Between Transmitter and Receiver, and "d" the Height of the Absorbing Layer.

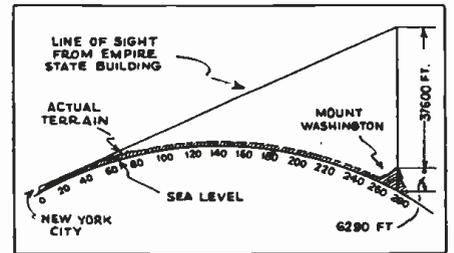

Fig. 10. Profile from New York to Mount Washington.

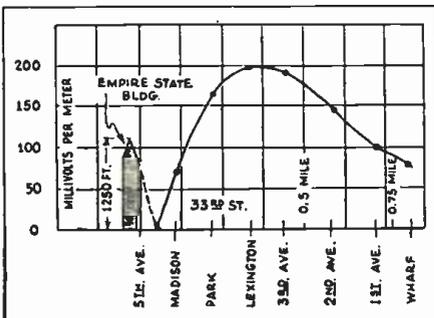

Fig. 7. (left) Field Strengths Immediately Adjacent to Transmitter.

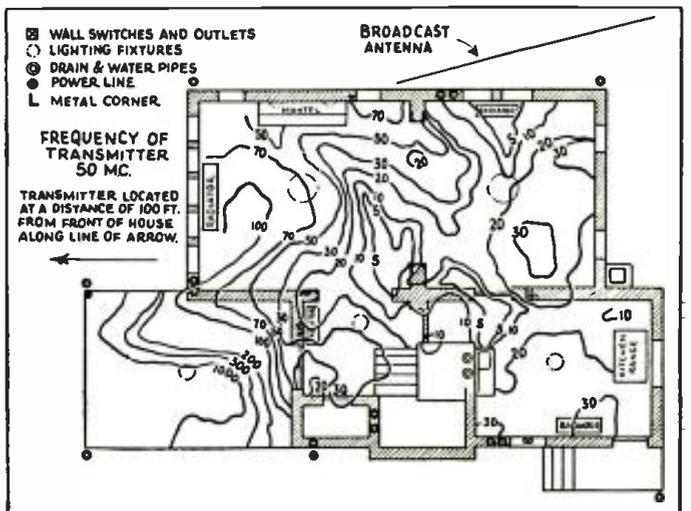
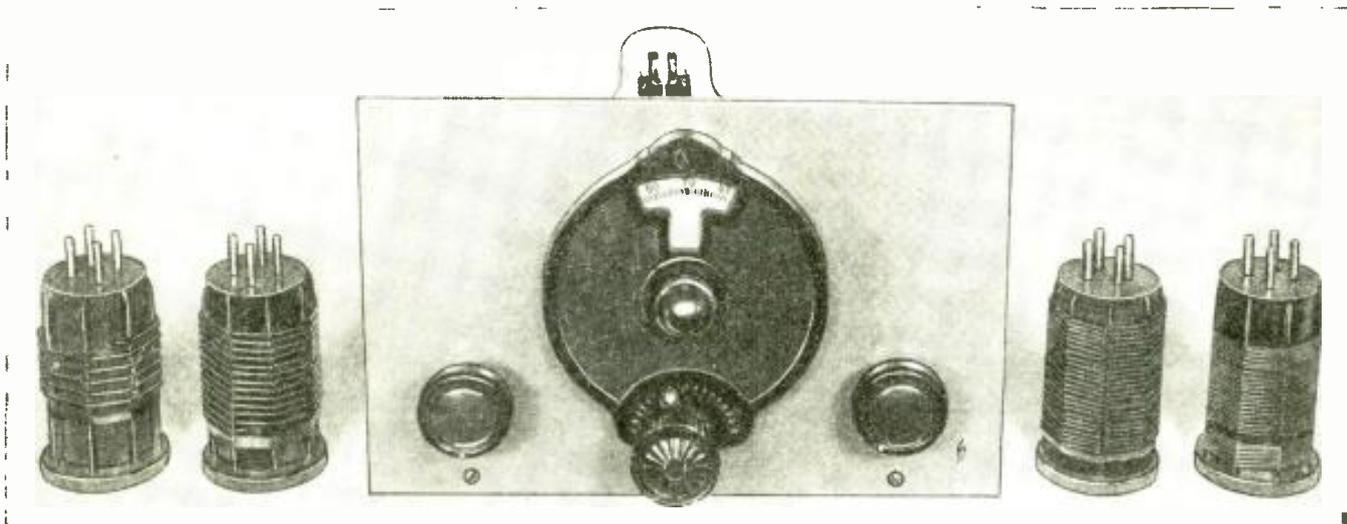

Fig. 9. (right) Field Strength within a Residence, 50 Megacycles.



Here we have a front view of the 1-tube "Twinplex" receiver developed by Mr. Worcester. 1 tube does the work of 2!

The "53" 1-Tube TWINPLEX

\$20.00 July Prize Winner

By J. A. WORCESTER, Jr.

Here's a 1-tube receiver that actually works like a 2-tube receiver, and as Mr. Worcester points out probably the most popular short-wave receiver for phone reception is the "2-tuber"—comprising a regenerative detector and a single audio amplifier stage. By taking advantage of the new type "53" tube, which really comprises 2 tubes in one, the author was enabled to evolve the "Twinplex" circuit, so that a single tube is made to operate jointly as a detector and also as an A.F. amplifier! Both CW and phone reception are afforded.



pentode without the latter's disadvantages of wiring complications and heavy plate current drain, which makes the use of an output coupling device practically a necessity if possible damage to the headphones is to be avoided. The heater-cathode construction effectively reduces hum and obviates the necessity of employing a center-tapped resistor with its consequent wiring complications.

(Continued on page 357)

● IT can be stated, without possible fear of contradiction, that the most popular short-wave receiver from the constructor's standpoint, at the present time, is a two tube affair consisting of a regenerative detector and one-stage audio amplifier. It is, of course, true that many home built receivers also include a stage of radio frequency amplification, either of the tuned or aperiodic variety, and possibly an additional stage of audio frequency amplification, as well; to provide sufficient volume for loudspeaker operation under favorable conditions. However, those fortunate enough to afford these more complicated receivers generally prefer to purchase one of the many excellent commercial receivers employing such circuits rather than to undertake the construction themselves; as the savings that can be effected thereby are generally not sufficient to justify such a procedure.

The average prospective constructors, becoming interested in short wave reception for the first time prefers as simple a receiver as possible consistent with satisfactory results. A one tube receiver is undoubtedly the ideal solution but unfortunately such a receiver of the conventional regenerative variety will not produce sufficient volume for satisfactory headphone reception. The writer has been interested for some time in designing a one tube receiver which would retain all the essential features of the conventional two tube

receiver and at the same time produce the simplification in wiring and apparatus effected by the single tube construction.

New 53 Tube Employed

The schematic wiring diagram of such a receiver is shown in Fig. 1. The tube employed is the new 53 which really consists of two tubes in one. This tube was designed as a Class B Twin amplifier but due to the comparatively large static plate current drawn, it can be readily adapted to detection and Class A amplification.

As an audio frequency amplifier this tube is very effective since its amplification factor is about 35. This permits an amplification approximating that of a

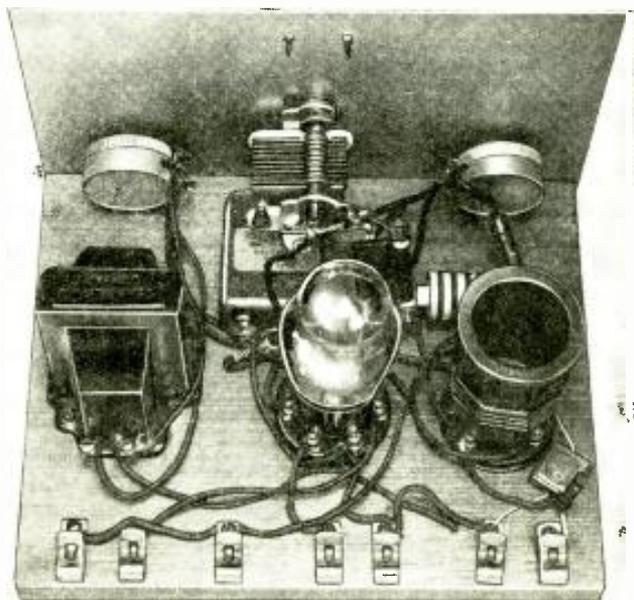

Looking at the back of the 1-tube "Twinplex," in which a single 53 type tube performs as both detector and A.F. amplifier.

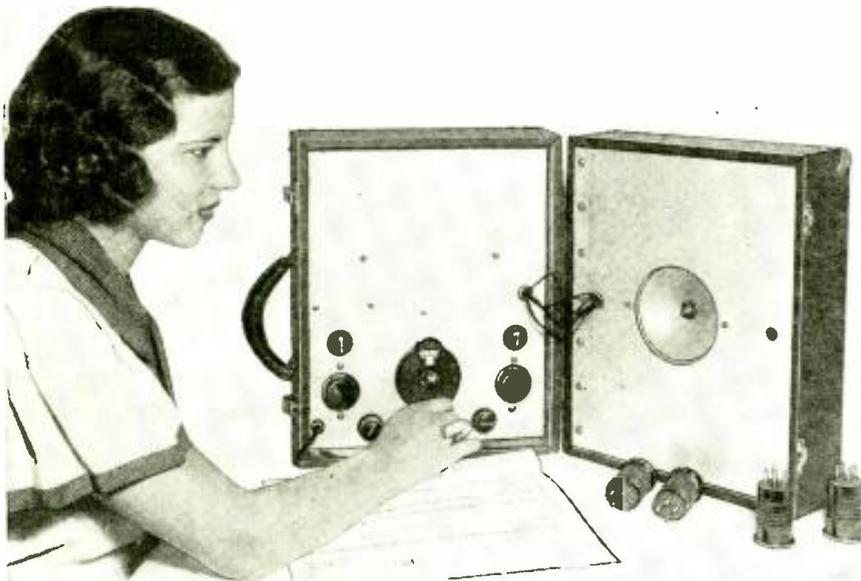

The "Rex" Portable Superhet Receiver brings in distant stations on even a short antenna.

The editors have received many requests from readers of this magazine asking for a medium weight, portable short-wave superhet receiver. They are glad to present such a portable set herewith which embodies some of the latest design features and which also employs carefully selected latest type 2-volt battery tubes. The carrying case contains all necessary batteries as well as loud speaker. "Band spread" is included among other features and high economy is assured by the use of but 5 tubes.



The "REX" Portable Superhet Short-Wave Receiver

By Clifford E. Denton and H. W. Secor

• THE problems encountered in the design of a compact short-wave superhet are manifold and this design is one of many developed in a series of tests extending over the last few months. This particular design was finally evolved as the most compact in size and most satisfactory in operation.

Band-spread tuning controls and the use of the superheterodyne circuit results in remarkable selectivity and sensitivity with a minimum of background noise. The receiver has six

tuned circuits, two of which are manually tuned by the operator and these two controls are mounted on a single shaft in such a way that *single-dial* tuning is possible over a considerable portion of the tuning dial when the *tank* tuning condensers are properly set.

Coils can be obtained on the open market permitting the operation of the

set on all wavelengths ranging from 10 to 550 meters. The intermediate frequency used with this receiver is 465 kc. and this frequency works out very well in practice.

The receiver is entirely self-contained, including the batteries and the loud speaker.

New light-weight "A" and "B" batteries play an important part in the space and weight reduction of the completed unit.

Provision is made in the *input* circuits of the first detector, so that a Lynch *doublet* type of antenna can be used, as well as the more conventional types of receiving antennas. Tests conducted under various operating conditions in conjunction with different types of antennas resulted in the choice of the doublet type for the best operation. This does not mean that this receiver can only be operated with the doublet system, but that excellent results can be obtained on most any type of antenna available.

Satisfactory loud-speaker operation can be obtained on all bands and the so-called "foreign locals" come in with ample volume.

Description

The entire set, speaker and batteries is contained in a leatherette covered carrying case measuring 14 by 11 by 7½ inches.

The shallow compartment houses the batteries and the loud speaker. The loud speaker is fastened to the aluminum panel by means of machine screws and the batteries are held in place by means of small wooden cleats fastened into place by means of wood screws.

(Continued on page 371)

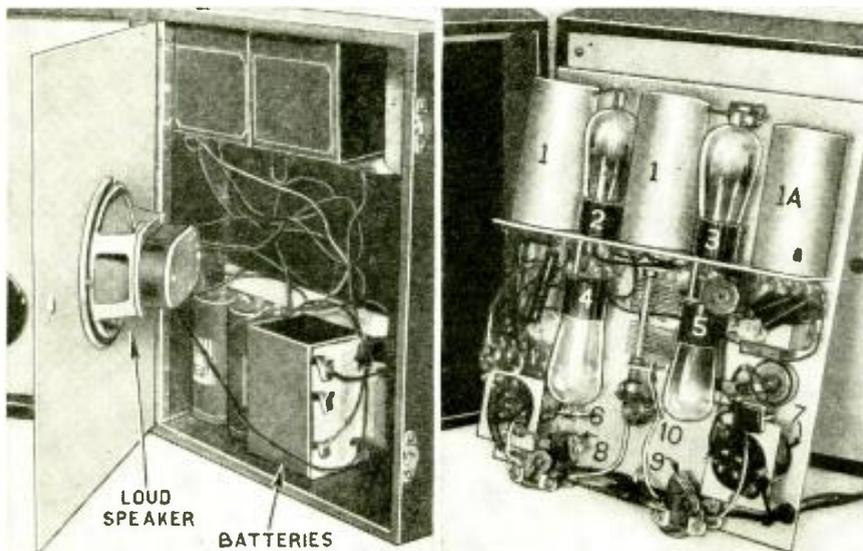

Photos above show rear view of the superhet and also interior of the loud speaker and battery compartment. The numbers on the chassis indicate the following parts: 1—l.f. transformer; 1A—33 type tube (audio amplifier) under can; 2—type 34 tube; 3—type 32 tube; 4 type 32 tube; 5—type 30 tube; 6—first detector coil; 7—oscillator coil; 8 and 9—tank condensers.

A Novel S-W Converter

By R. M. LEGATE

● YOU haven't heard from me before but for two years I have been a silent admirer of SHORT WAVE CRAFT and have read with great interest your articles and letters from "Hams."

Being an unemployed electrical engineer and knowing nothing whatever about radio, I am sending you a few details on my receiver. I have tried all kinds of circuits and combinations and obtained excellent results with some of them, but the one that has absolutely astounded me is the one I give herewith.

There is nothing new in either the broadcast or the short wave circuits; the one is a circuit I took from SHORT WAVE CRAFT'S "Question Box" of a few months ago and the other is a model 801 Westinghouse superhet broadcast receiver, but experimenting in my ignorance I hit on the attached combination. The sensitivity and volume that this receiver gives is really wonderful and is the envy of all the local "hams."

The circuit explains itself; the change-over switch shown in the assembly sketch controls two "ganged" toggle switches marked 1-2-3 and 4 on the diagram. A D.P.D.T. switch transfers the converter output to the grid cap of the 1st detector tube in the superhet, and at the same time transfers the antenna from the B.C. (broadcast) to the short-wave converter, the other switch turns on the filament of the converter tubes and at the same time cuts off the filament of the B.C. oscillator.

Please don't ask me how or why—I don't know. I am simply passing on

Here is a novel short-wave converter circuit which Mr. Legate ran across in some of his experiments with a superhet broadcast receiver. He has heard stations "all over the globe" at loud-speaker volume with his "stunt" circuit, when not a peep could be heard on a commercial 11-tube short-wave set which he used for comparison.

the results of my "discoveries." I have compared this receiver side by side to two well-known manufacturers 11-tube sets and in some cases, when I haven't

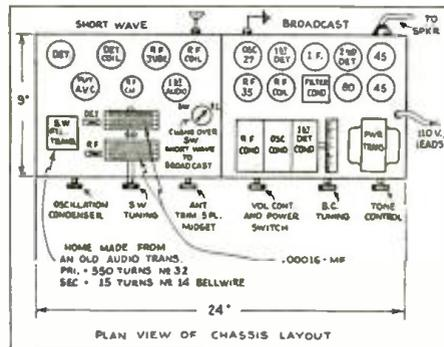

Top view of chassis layout used by Mr. Legate for his combination "short" and "broadcast" wave receiver. The short-wave receiver employs an R.F. stage, a regenerative detector, and also an audio coupling stage.

been able to pick up the wave on the manufactured set, it has come in loud and clear on my set!

Today for example, GBS-GSA and W8XK came in with such terrific volume that with my volume-control full off and oscillation condenser full out, I had to put my finger on the grid cap of the I. F. tube to reduce the volume sufficiently to understand the speech, and this isn't a tall story! This condition is no doubt due to the fact that with the way I am using the B. C. circuit I have only the one tube (I.F.) controlled.

I have tried feeding the converter output into the B.C. set antenna, but this requires that the B.C. dial be set as near 550 k.c. as possible while in my arrangement the B.C. dial does not affect the short wave tuning and the noise ratio is away down.

I wish you would publish a suitable and simple A.V.C. circuit for use with this hook-up and I would be glad to hear from you or any of the "hams" who might try this stunt circuit and let me know what they think of it. I am enclosing a partial log.

Stations Logged

Only stations received with good loud speaker volume are included here and all these stations have been logged during the past 6 months.

| | | |
|-------|----------|---------------------|
| P.T.E | 15.93 m. | W8XK |
| W3XAL | | W2XE |
| GSG | | W3XAL |
| W2XAD | | VE9GW |
| FVA | 19.68 | W9XF |
| W8XK | 19.72 m. | W8XAL |
| DJB | | W3XAU |
| GSF | | GSA |
| XDA | | W4XF |
| | | All the GB stations |

(Continued on page 362)

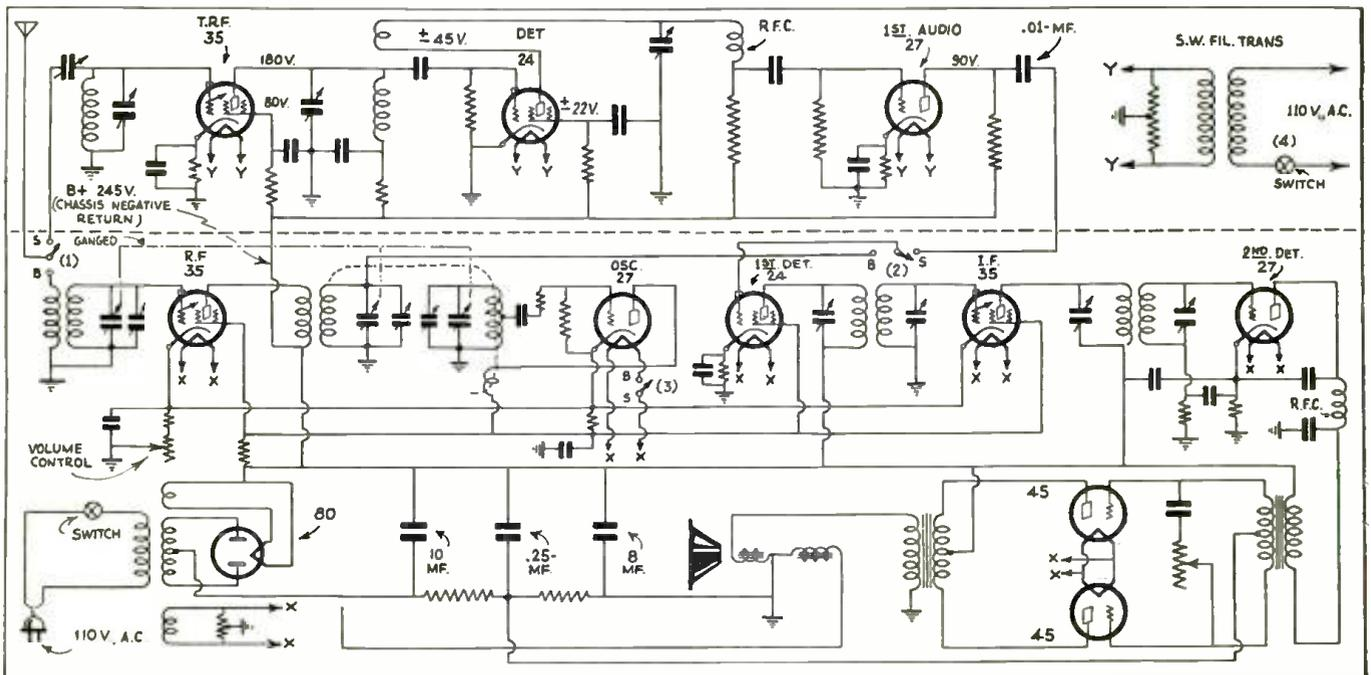

Complete wiring diagram of Mr. Legate's ingenious circuit on which he received short-wave stations from "all over the globe" with tremendous volume. The three tubes shown at the top of the circuit comprise the short-wave converter as constructed by the author, while the remaining tubes and associated apparatus indicated below the dotted line comprise the regular set-up of the standard commercial "broadcast" receiver he used. By means of the two single-pole double-throw switches indicated at 1 and 2, the operator is enabled to quickly switch from "broadcast" to "short-wave" reception, the output of the special converter being fed into the grid of the first detector of the broadcast set. By using the set-up of tubes as here shown, a very smooth and gradual amplification of the incoming signal is realized and when it finally passes through the two 45 A.F. amplifier output tubes into the dynamic speaker, the signal has some wallop!



The "Minidyne" in operation—with the latest type miniature phone which fits into the ear.

Behold the MINIDYNE!

No Aerial— No Ground!

By **SAMUEL S. EGERT** and
SAMUEL BAGNO*

This tiny one-tube receiver has picked up police and other short-wave stations over 100 miles away, without an aerial or ground! It has even picked up short-wave stations while being carried in a New York subway train under-ground. The set is entirely self-contained with batteries, tube, condensers, and loop.

AS there is a constantly increasing tendency to-day toward portability in radio receivers, your authors deemed that it might be of interest to the readers of Short Wave Craft to know of a really portable amateur band short wave set. As you can see by the illustrations, the receiver is really ultra portable, as it requires nothing but an outside ear piece in addition to its self-contained equipment. Batteries, tube and antenna are completely inclosed in the unit, along with the band changing switch, tuning and volume controls. The unit has been designed ruggedly to

make it withstand the terrific bouncing which an auto-portable would naturally have to withstand. The total weight of the receiver is $3\frac{3}{4}$ lbs., and its dimensions are 5x5x6 inches, thereby making it adaptable for any type of portable work.

A receiver of this type would make a convenient companion on mountain hikes, river trips, regular jaunts, etc. Aside from these practical applications there is the thrill of hearing things by radio when you are actually walking along in an unconcerned manner.

Highly Sensitive Circuit Used

The circuit employed in the unit is a modified form of the Flewelling super-regenerator receiver. The designs were originally conceived by the desire of the authors to make a receiver which could be used by the great armies of infantry police. It can be seen that a unit of this type could readily be adapted for that service, as it would enable headquarters to be in touch with every policeman on their individual force. Due to the rigorous requirement necessary for this type of work, the circuit was constantly im-

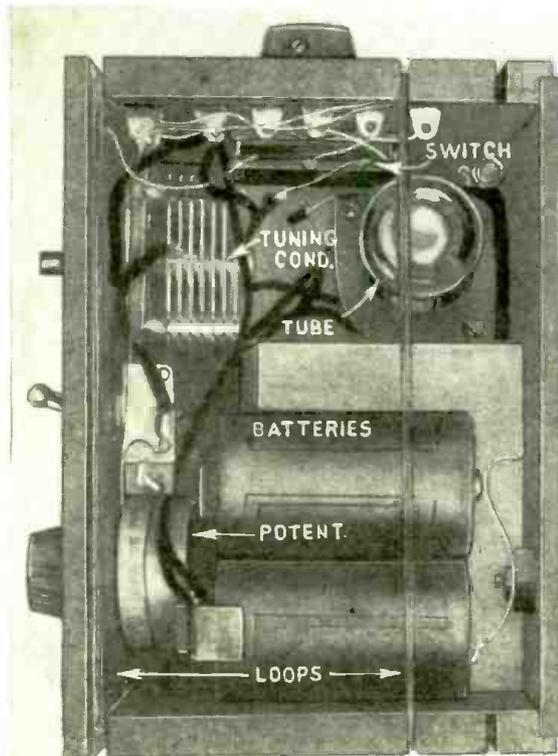

Photos here show outside and inside view of the "Minidyne"—the tiny one-tube self-contained short-wave receiver which operates without aerial or ground as you carry it about.

Photo at left shows interesting inside view of the "Minidyne"; the method of winding the pick-up "loops" in slots cut in the sides of the cabinet is made clear.

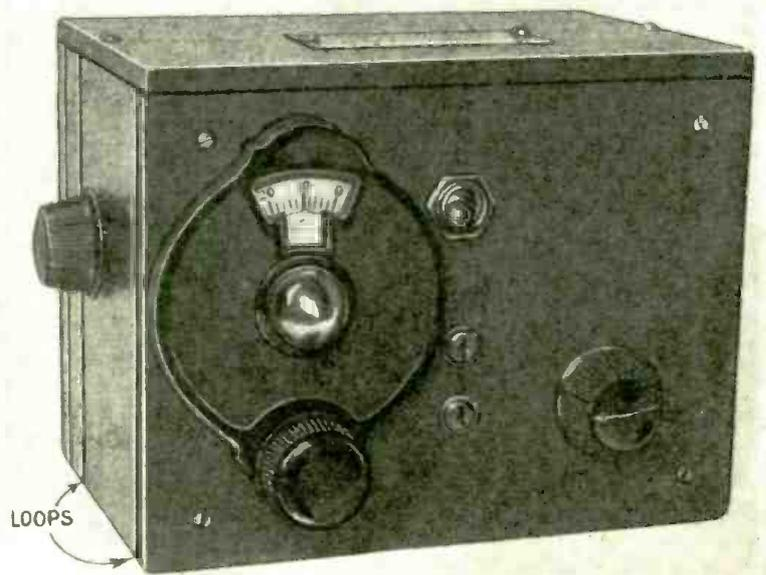

*Wireless Egert Engineering.

proved until it was felt that the sensitivity of the unit was high enough to be acceptable. The sensitivity in this way was increased to such a degree that the signals from a modulated speech police-broadcasting station were actually heard in practically every locality and every subway in greater New York. Signals were also picked up from Philadelphia and other outlying cities about New York on the 125 meter police phone band.

A great deal has been written about the super-regenerative circuit within the past six or seven years. The super-regenerative circuit is a derivative of the Armstrong regenerative circuit. Almost everyone knows of the latter.

Action of Ordinary Feed-back Circuit

Figure 1 illustrates one of the conventional methods of obtaining regenerative feed-back. The action of this arrangement is as follows: A signal from the antenna is impressed on coil A and fed inductively to coil B. This signal is then amplified by the Tube T1. After amplification some of the original signal is fed to coil C which is inductively coupled to coil B. In this circuit just enough current is fed back to overcome the resistance of the antenna circuit. There are no interruptions whatsoever in this circuit. Straight regeneration is nothing more than creating a path of zero resistance in the circuit when the latter is in a non-oscillating state.



Here is the very latest style earphone for radio receivers—it weighs but 2 ounces and fits right into the ear. It has a resistance of 2000 ohms. (Refer to No. 118.)

Super-regeneration on the other hand adds an additional oscillator to the original type of Armstrong regenerative arrangement. The circuit fundamentally operates somewhat differently than the straight regenerative.

The Super-regenerative Circuit

Figure 2 illustrates a standard type super-regenerator. In this arrangement there are two fundamental frequencies being generated, one a high frequency (frequency of the incoming signal) and the other of a lower frequency, approximately 18 to 50 kilocycles. The action of the circuit is described as follows: The incoming

signal is impressed on the loop A and amplified by the high frequency tube T1. This signal is then fed back to the antenna loop A and again reamplified by the tube T1. This action continues until the signal is amplified to some value. The signal is then made to dissipate itself in the antenna resistance by blocking off the amplifier tube. This is accomplished by means of the low frequency oscillator. It can be seen that if the amplifying tube was not blocked intermittently by the low frequency oscillating tube, the incoming signal would be completely out of control. The main advantage of the super-regenerator is this ability to amplify the incoming signal recurrently until the latter is built up enormously, and then being able to dissipate this signal before it goes out of control. In this way the sensitivity of a good super-heterodyne receiver can be obtained with one or two tubes.

Circuit Used in the Minidyne

Figure 3 illustrates the circuit employed in the Minidyne. Note that in this arrangement the feed back of the high frequency tube is brought back in the loop itself through coil E. Each frequency band has its own loop coil. Note that only one tube is employed here. The low frequency oscillator is introduced by a relaxation circuit; in this way the tube serves two purposes, as it not only acts as the amplifying tube for the incoming

(Continued on page 364)

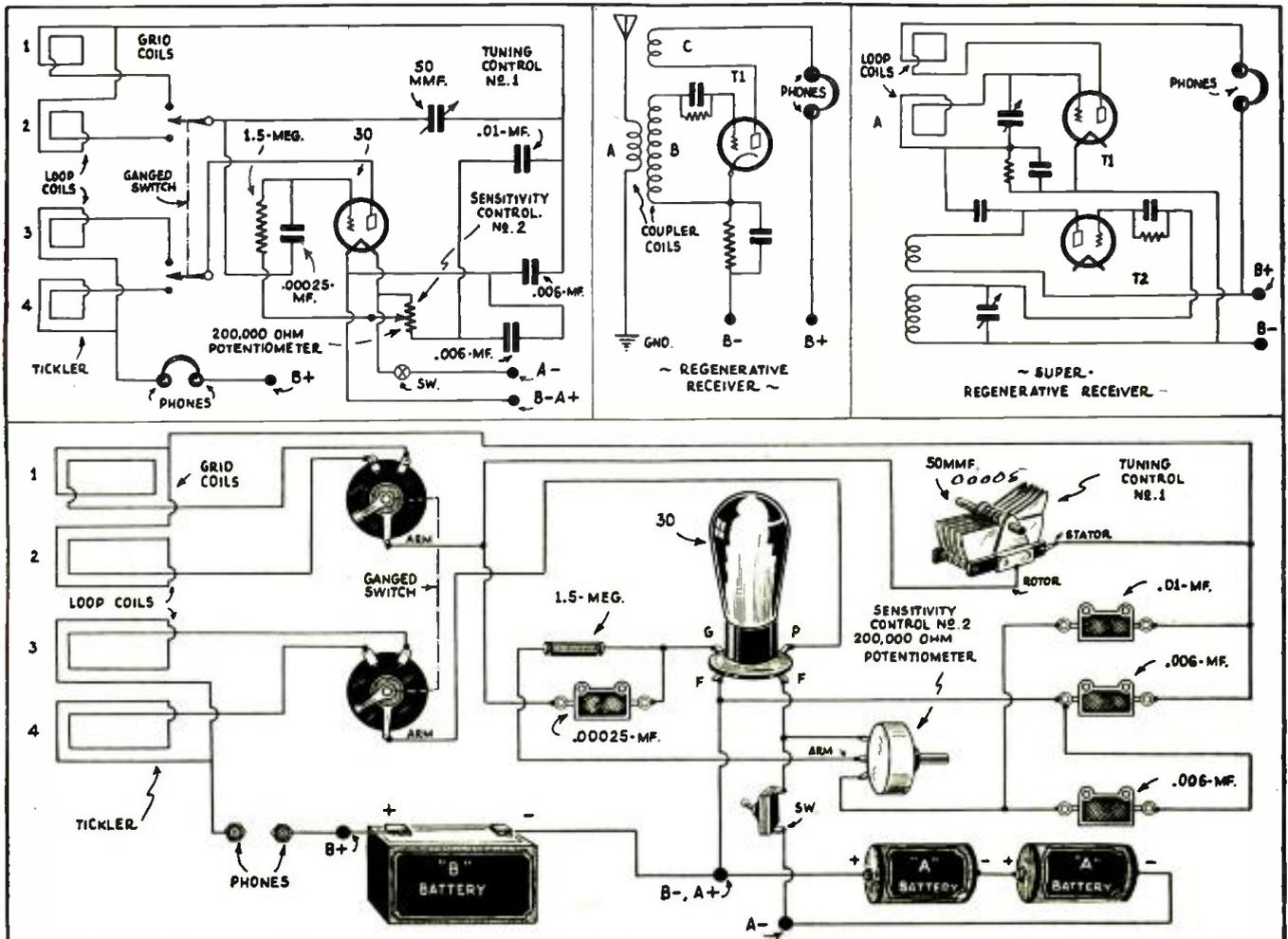

Complete wiring diagrams, both schematic and picture style, are given above showing how to build the "Minidyne." Fig. 1, Regenerative Receiver; Fig. 2, Super-regenerative circuit; Fig. 3, Top left, Minidyne circuit.

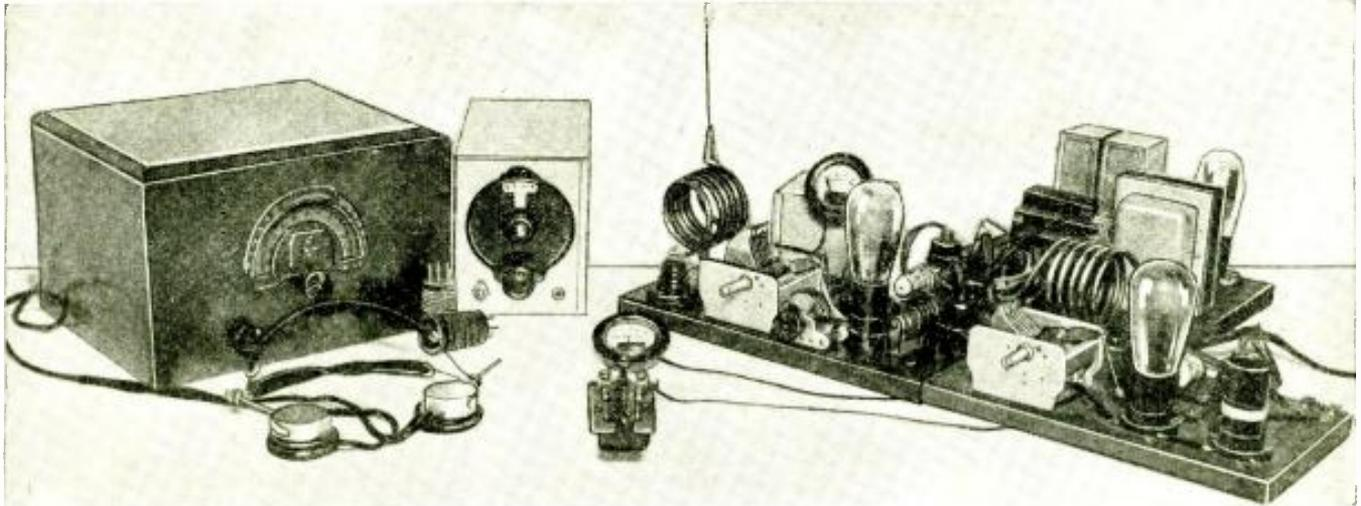

Complete short-wave station set-up, with S-W receiver at the left, together with the M.O.P.A. transmitter at the right.

Amateur Transmitters

How to Build, Install, and Operate Them

In this second article on Amateur Transmitters, Mr. Victor explains at length how to build the greatly desired *Radio Frequency Amplifier* for use with the oscillator described last month. Among other advantages gained by the use of an R.F. amplifier for transmitters are the steadier signal and the greater percentage of modulation which can be obtained.



By **LEONARD VICTOR**
W2DHN, W2DPT

● THERE are innumerable advantages to be gained by the use of a radio-frequency amplifier, among which only the major ones will be mentioned here. Uncle Sam, through the Federal Radio Commission, has enacted regulations to the effect that *phone* should not be used on a *self-excited* oscillator—hence the need for an *R.F. amplifier*. Modulating an oscillator directly causes a broad, mushy signal that eats up far too much space in our already over-crowded "ham" bands. Likewise modulating an oscillator on the 160 meter band will inevitably cause complaints from broadcast listeners in the neighborhood.

Oscillator modulation cannot be increased above 30% without bad distortion, whereas 100% modulation can be used on an amplifier. Since a ten watt, 100% modulated carrier is just as effective as a fifty watt, 30% modulated one, it will be seen that much less power gives far better results when an R.F. amplifier is employed.

An amplifier greatly increases stability, that is, gives a much steadier signal, and, usually, a better note than just a straight oscillator. Those who have used self-excited, self-controlled outfits have probably noticed that when the aerial moves in the wind, there is an annoying change in frequency. Likewise any change in plate voltage or load conditions brings about a corresponding change in the frequency of the transmitter. Using an amplifier, there will be no noticeable shift in the note, even during a heavy storm, and

the plate voltage may vary as much as 25% without detrimental results.

Just as when an amplifier is used on a receiver, greater power output is obtained. With a grid input from the tank of the oscillator of only 3 to 5 watts, outputs of the order of 15 to 25 watts can be obtained.

This particular arrangement of oscillator and amplifier works excellently on all bands and is admirably suited for future use as a *phone* transmitter.

As in the single-control transmitter, the buying cost is kept low, and the unit is very simple to build and operate.

During tests with a station in England, the power (plate volts times milliamperes) was gradually lowered until we were finally putting signals across the "big pond" with less than 10 watts input! That is, we were actually using less power to work 2,700 miles than would light a small electric light bulb!

Technical Description

A radio frequency amplifier is very much like an audio amplifier used in a receiver. It has a *grid input* circuit which gives it *push* or *excitation* as it is called from the preceding stage (in this case a self-excited, self-controlled oscillator).

A single tube of the 46 type is used; this tube is admirably suited to "ham" use because of its relatively high efficiency. It requires no *battery bias* for good operation, which eliminates one of the nuisances in *phone* work. Like-

wise, because of the very high *gain* of the tube, very little excitation is necessary. This allows running the oscillator greatly underloaded and produces a very steady note. This is likewise highly desirable for *phone* work, as with less excitation there will be less intercoupling between oscillator and amplifier.

The 46 has two grids between the filament and plate. These are tied (connected) together, making a very high impedance tube.

There is a tuned plate circuit which uses the same size coil and condenser as that employed for the oscillator, (described in first article, last month.) For *code* (C.W.) work it will be found better to use coils with a few more turns, and hence use less of the condenser capacity in tuning to the same frequency. The less condenser and the more coil used in a transmitter, the higher the efficiency. However, the less the condenser, the lower the dynamic stability. A happy medium has to be experimentally struck and is slightly different for *phone* or *code*.

The customary by-pass condensers are used in both the filament and plate circuits. Plate voltage is fed at the center of the tank coil as this is the "cold spot" of the transmitter.

Also there is a midget variable condenser, called the *neutralizing* condenser, which cancels the grid-to-plate capacity of the amplifier tube and prevents it oscillating of its own accord on a different frequency than the pre-

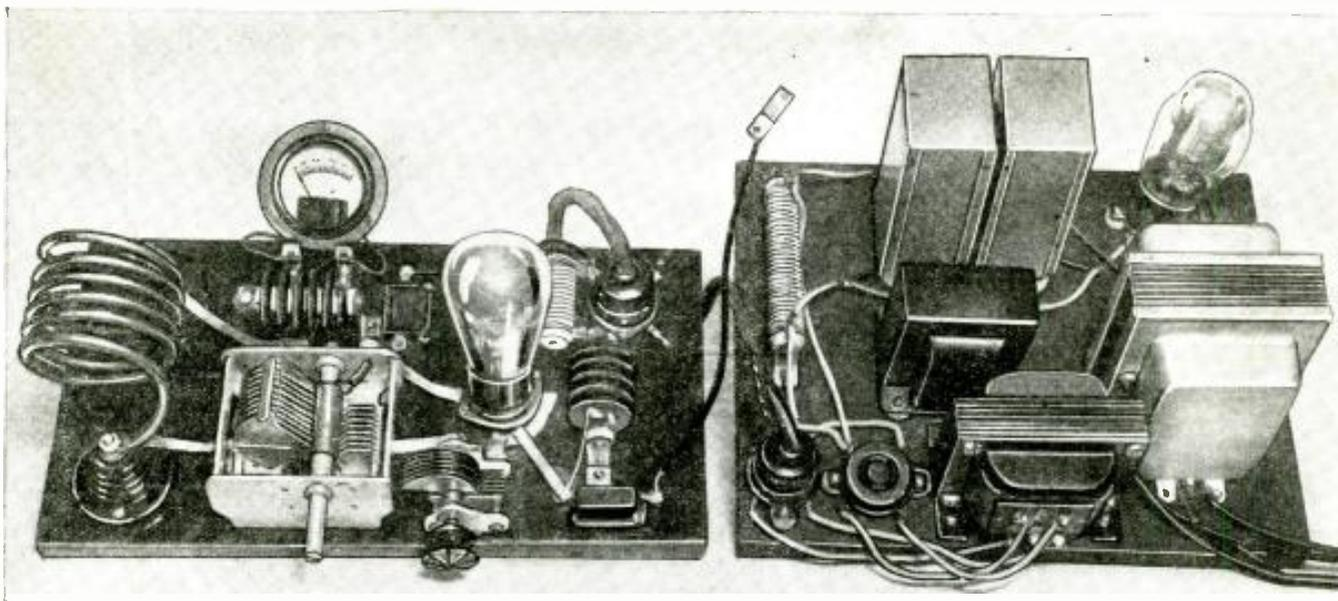

The neutralized amplifier and power-pack for use in conjunction with the Master Oscillator described in last month's article by Mr. Victor. This power amplifier uses a 46 tube and requires no external biasing battery.

ceding stage, which should not occur. The R.F. chokes used are very heavy duty units which happened to be handy, but almost any good choke can be used. Test your chokes with a neon bulb. There should be no glow at the "cold end," but a pronounced glow at the tank end of the choke.

Chokes for transmitting purposes should be of low resistance and be capable of handling heavy current. The actual value of a choke can only be proven under test.

Care should always be taken to use good fixed condensers as this has a great deal to do with the final performance of the set.

Likewise the variable tank condenser should have very good insulation between the stator and rotor.

Building the Transmitter

Looking at the accompanying pictures and diagrams there should be no trouble experienced in building the

unit. The baseboard is 7" x 13"; sandpaper and varnish this board for a neat appearance. The three condensers mounted in a row at the back of the board are the .002 mf. filament and plate by-pass condensers. The plug from the power cable plugs into the 4-prong socket at the rear right of the transmitter. What is normally the cathode connection on a 5-prong socket, and the grid connection, are soldered together for the two grids of the 46. Spacing between the stand-off insulators is five inches.

All tank connections are made with tinned copper braid, and the filament and choke connections are made of busbar covered with spaghetti insulation. Extreme care should be taken with the wiring, inasmuch as one poorly soldered connection will inexplicably spoil the operation of the transmitter.

Power Supply Details

A different power supply is used this

month, because the current drain is much higher. Also, for voice (phone) work later it will be necessary to use two power supplies. The power transformer is a substantial unit supplying 400 volts at 150 mills (milliamperes). 5Z3, the successor to the 280, is used as a rectifier tube. This tube has very low voltage drop, and passes high current. A 4mf. electrolytic, a 30 henry 150 mill. (M.A.) choke, and an 8 mf. electrolytic condenser comprise the filter circuit. A 20,000 ohm, 50 watt resistor is used as the bleeder resistance. The two power supply plugs, to go to the oscillator and amplifier have parallel plate and grid (really plus and minus) connections, but different filament supplies. A separate filament transformer is used to afford better regulation; if the filament windings were on the power transformer, their voltage would fluctuate with the load drawn from the high voltage circuit.

(Continued on page 372)

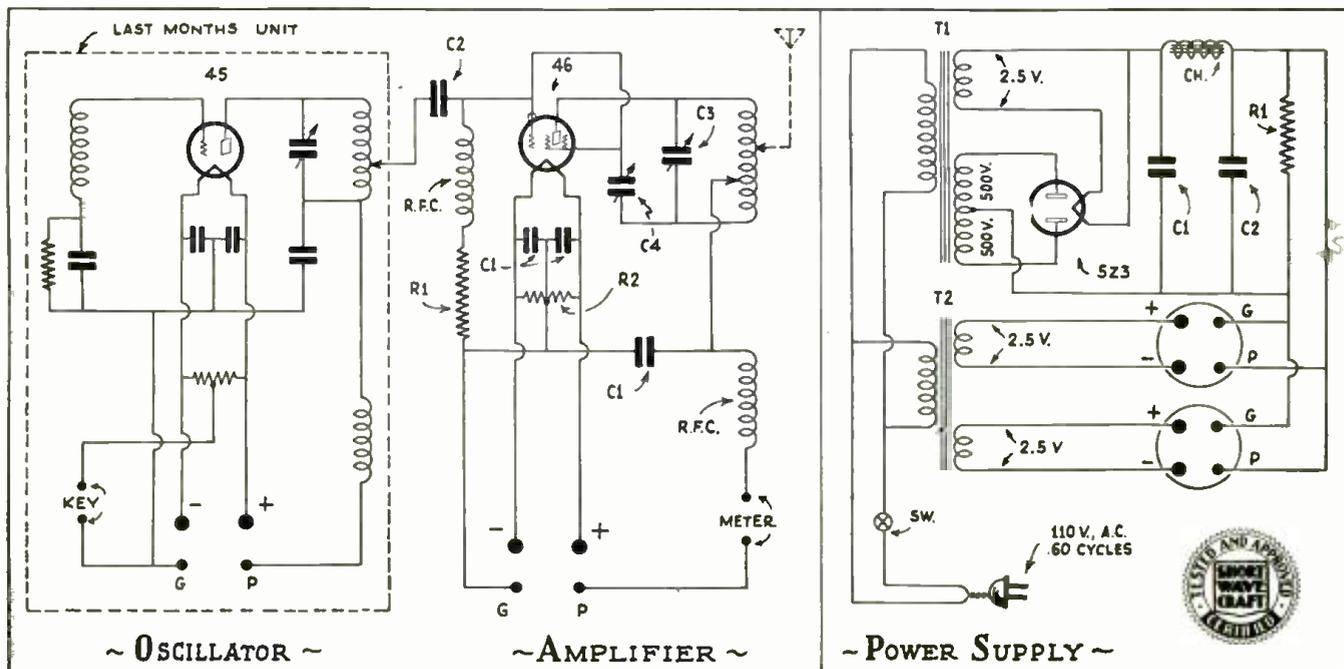

Diagram of Oscillator and Power Amplifier Circuit; also Power-Pack.



Mr. Victor is here shown in the act of calibrating the monitor.

How to CALIBRATE the MONITOR

Last month's article described how to build a monitor and in the present article Mr. Victor explains how to go about the calibration of the monitor.

● THE simplest use of a monitor is for setting a transmitter at a pre-determined frequency. To do this it is only necessary to find a blank spot in the frequency band, tune the monitor to it, and then tune the transmitter on the monitor. However, this method does not allow the setting of the transmitter on a known frequency, and frequently it is desirable to operate on an exact point for schedule purposes or traffic handling. Likewise it is occasionally necessary to operate very near the edge of the band, and this is a very hazardous proceeding, without the aid of some calibrated medium. Also a monitor that has been carefully calibrated can be used to find the approximate location of DX broadcast stations that are coming in weakly. It is a great aid to be sure you are listening to the right station when call announcements are fifteen minutes or half an hour apart.

Method of Procedure

The process of calibration is very simple, and should not take more than about five minutes per band. The first requisite is extreme stability in the monitor. All leads should be tight, all coils collodioned, and the batteries up to full voltage. Let us take the 40 meter band as an example. We know that the band covers approximately from ten to eighty-five on the monitor dial, because almost all the "ham" stations are within those limits. Just below the band, on a spot that corresponds to five on the monitor dial, we hear station ABC. Looking up ABC in your "log" book you find that its frequency is 6,975 KC. Fine, this station is right near the band and will serve as an excellent "marker" station. At the point where 6,975 KC. and 5 on the dial settings meet, put a dot on the chart and mark station ABC. Then tune in a station, of known frequency, near the center of the band and mark this down. Now tune above the band. At 95 on the dial we find station XYZ which the log book tells us is 7,350. Mark that on the graph, and then rule a line between these three points. Presto, the calibration is finished. It immediately tells us the band is from 5 to 95 on the dial, and we can set our monitor on any frequency (plus or minus about five kilocycles for error), by simply consulting the graph and

setting the monitor condenser dial according to it. The same type of calibration can be made for the short-wave broadcast bands, so that if you wish to go hunting VK3ME when a dozen other stations are on, your time will not be wasted listening to European "locals." To check calibration and make sure the dial settings are

Next month's article on Amateur Transmitters—How to Build and Operate them—will explain How to Add a Modulator for 160 Meter Phone.

O.K. merely retune the receiver to one of the "marker" stations (only those stations that are on the air consistently should be chosen as "markers"). Then tune the monitor to the incoming signal and the dial number should check to the graph. If the monitor fails to hold calibration test both tube and batteries. A one or two plate

midget condenser can be mounted in parallel with the monitor tuning condenser and be used to reset the calibration at the right number. Be very careful that this condenser is tight and does not slip while using the monitor, as it would ruin the calibration.

In like manner to the monitor, a short wave receiver can be calibrated, particularly if it has the essentials of *stability*. That is, an R.F. stage, stable detection (preferably electron-coupled) a very good vernier dial, isolantite insulated condensers, and a regeneration control that does *not* affect tuning. The receiver in use at this station has all the previously aforementioned features and was found to operate admirably, having held its calibration for several months now.

Actual stations are not mentioned for calibrations, as dial settings would obviously vary. Be sure to get an up-to-date call or "log" book, as short-wave stations frequently vary their wavelengths.

In a series of articles in future issues, very accurate methods of frequency determination will be completely described.

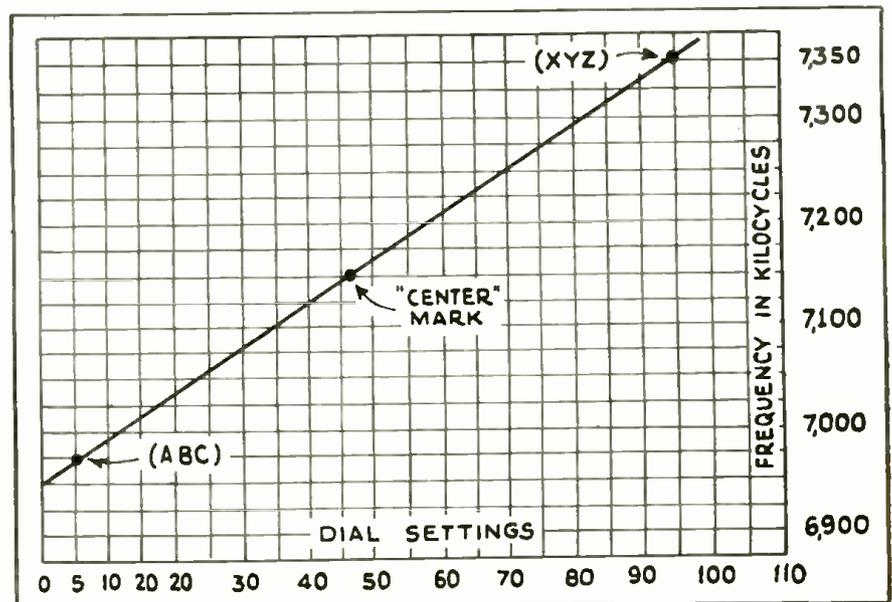

A typical monitor calibration chart.

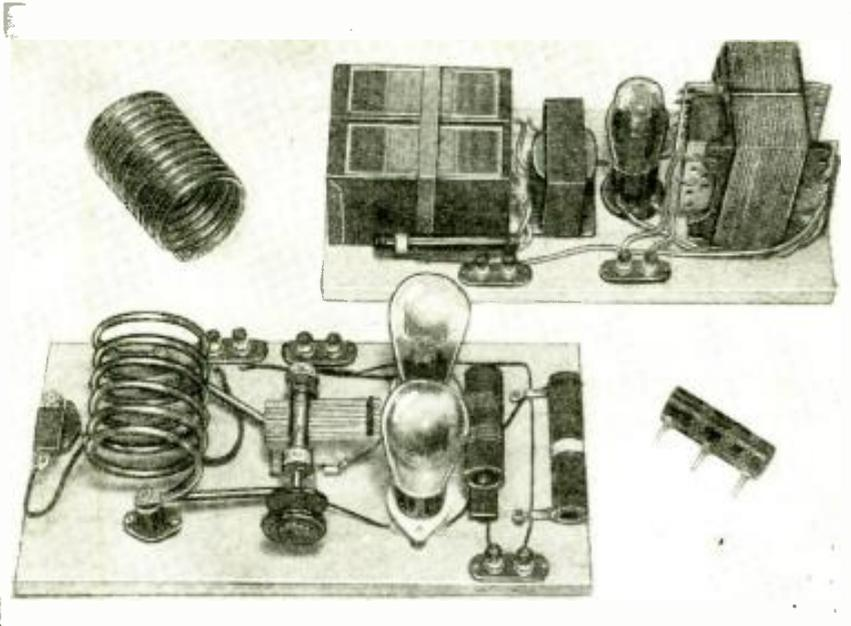

Here we have a fine view of the complete 45 push-pull Beginner's Transmitter and power supply unit. Extra wave band coils are shown.

The "RT" Beginner's Transmitter

By
GEORGE W. SHUART
(W2AMN-W2CBC)

Here is just the transmitter the beginner is looking for—it employs two type 45 tubes as oscillators, which yield practically as great an output as the 10 type tubes, at far less cost. Coil data is given as well as specifications for building the oscillator and also the power supply.

● THE transmitter described in this article is primarily a low power, low cost outfit for the beginner. Almost any one acquainted with radio transmitters will admit that a push-pull arrangement is far superior to the single tube variety. There is really no extra cost in building a push-pull oscillator, the only added expense is in the additional tube required. And for this reason the author cannot see why anyone would build a transmitter and not incorporate a push-pull circuit. Push-pull circuits are much more efficient, this is proven by the fact that just about every ultra short wave transmitter is of this type. If this type of circuit is more efficient on the higher frequencies, surely it should perform more than satisfactorily on the lower frequency bands.

Uses 2-45's as Oscillators

The outfit shown in the photographs uses two of the type 45 tubes as oscillators. This tube was used because of its low cost and the fact that it provides practically as much output as the regular 210, at one third the cost. The transmitter is divided into two sections namely, the radio frequency oscillator and power supply. The oscillator is mounted in bread-board fashion on a 7 by 15 inch plywood board which should be thoroughly dried and given a coat or two of shellac to prevent it from absorbing moisture in damp weather. The circuit is of the type using fixed-tune grid and tuned plate. All grid coils are wound on one inch bakelite tubing with fine wire, so that their natural frequency response is near the center of each amateur band. The frequency peak of this type of coil is rather broad and for this reason the entire band can be covered with the plate circuit, without the two circuits getting out of resonance. This is a desirable feature as any part of a given band can be worked on, with the plate circuit being the only tuning control. To facilitate the changing of grid coils for the different bands, each coil is equipped with three small plugs that fit into sockets mounted on a strip of bak-

elite fastened to the baseboard. The construction of these coils can be clearly seen in the drawings, and the number of turns for each band is given in the coil table.

Plate Coils of Copper Tubing

Next we have the plate circuit. The plate coils for the 20, 40 and 80 meter bands are constructed of one-quarter inch copper tubing. The 160 meter coil is of a different type. This coil is made by winding No. 12 antenna wire (solid enameled) on a two and one half inch bakelite tube four and one half inches long. Wind 25 turns on this tube very tightly, and space the turns with string of approximately the same size as the diameter of the wire. This winding is then covered with clear lacquer or some such material that is a good insulator. The other coils are spaced so that they just fit on the two stand-off insulators which are four and one half inches apart. A 500 mmf. receiving type condenser is used to tune the plate circuit and is shunted directly across the plate coil causing both rotor and stator to be at high RF (radio frequency) potential. This will cause noticeable hand capacity effects to be present when the condenser is adjusted and allowance should be made for this. Be sure to use a knob or dial that does not have its set screw exposed where the body will come in contact with it, or else a nasty burn will be the result.

Simplification Achieved

From the diagram it can be seen that no grid or filament bypass condensers are used and the familiar "RF" choke is omitted from the plate circuit. No benefit was derived from their use and for that reason they were not used. However there is no law against them; should the builder wish to incorporate them in the set, a .0005 mf. bypass condenser in the plate voltage supply lead is all that was found beneficial.

The method of coupling the antenna to the out-put circuit of the transmitter may cause some to wonder whether or not there is something wrong with the diagram. This transmitter was built

with a pair of antenna coupling coils, one coupled to each side of the plate tank and tuned with a variable condenser, just to see whether or not there was any difference in the out-put and the character of the signal. First one coil was eliminated and then both were taken out and the antenna connected directly to the plate coil with results being the same in either case.

Wiring the high-frequency part of the transmitter is done with regular hook-up wire and all connections well soldered, except the two leads connecting the plate coil to the tuning condenser; these leads are made of the same size copper tubing as the coils.

(Continued on page 371)

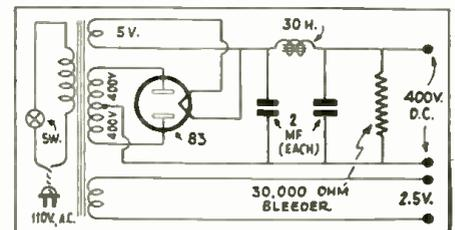

Power Supply unit diagram

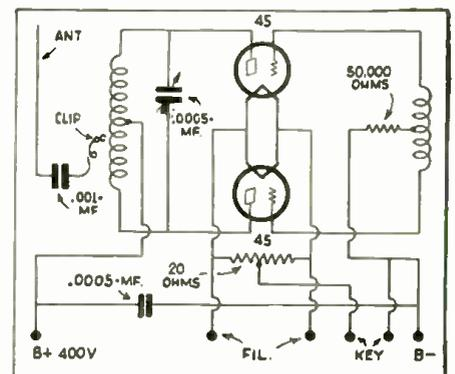

The diagram above shows the hook-up of the exceptionally few parts required in constructing the "RT" Beginner's Transmitter, which was especially designed by Mr. Shuart so as to embody the simplest possible construction at the lowest cost, without sacrificing quality and efficiency.

The EVOLUTION of

Mr. C. C. Whitehead, eminent English authority on ultra-short waves, here provides one of the finest resumes on the production of ultra short waves that the editors have seen.

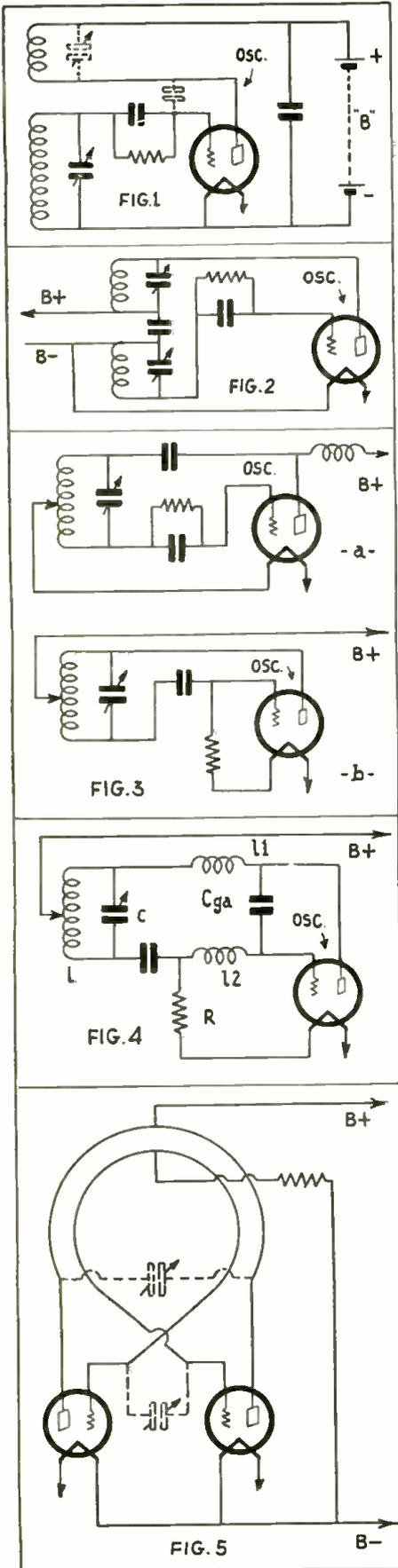

Fig. 1—The fundamental oscillator circuit. Fig. 2—Fig. 1, without (plate) battery. Fig. 3—A simplification of Fig. 2, (a) series and (b) shunt feed. Fig. 4—An oscillator for 4 meters. Fig. 5—The Mesny push-pull oscillator for waves of about 3 meters.

● SINCE the War, on account of the increasing congestion in the field of radio communication, attempts have been made to extend in every possible direction the range of frequencies available for this purpose.

At the close of the War the generally used wavelengths ranged between 100 and 20,000 metres (3,000 to 15 kc.). Since the 10-15 kc. range verges upon the audio-frequency spectrum, there was obviously no room there for extension, so wavelengths had perforce to be found in the zone below 100 metres (above 3,000 kc.). How the use of wavelengths below 100 metres and down to 15 metres was developed is now a matter of fairly common knowledge.

Of course, there was one great advantage in the possibility of using ultra-short waves, apart from the relatively efficient aerial systems which could be used in connection with them, i.e., the fact that stations could be "packed closer" (since the spacing was a matter of frequency difference) as the wavelength was reduced. Even so, the waveband between 15 and 100 metres soon became congested, and so the possibility of using even shorter waves was soon investigated.

Though it is not really within the province of this article, it may be profitable to discuss briefly the properties of these very short waves. As predicted by theory, it was very soon discovered that they were too short to be reflected or refracted by the ionosphere, and therefore there was no phenomenon of "skip distance," due to the presence of the direct and indirect rays. Also the "ground wave" suffered very rapid attenuation, so that sending or receiving apparatus situated close to the ground had a very short range. In fact, the range bore a direct relationship to the height of the antenna from the ground. If, however, the two stations were situated so as to be within sight of each other, very long ranges were obtained with very small powers. The waves behaved in this way in a very similar manner to the much shorter light waves, thus earning for themselves the name "quasi-optical."

Very early during the pioneer work on these waves in the field of communication it was suggested that it would be possible to control the "service area" of a transmitter by altering the effective height of the antenna. The use of directive aerial systems was also easy and economical.

But some workers in this particular branch of radio communication have long felt that, in spite of theory and early results, it might be possible to attain long ranges with these waves. Some recent experiments have tended to confirm this view, ranges well beyond the "optical range" having been attained, first between France and Corsica on wavelengths of the order of 3 metres, and lately between ship and shore over a distance of 168 miles on a wavelength of 57 centimetres.¹ The mechanism of propagation in these cases is not yet understood.

Prior to this time, methods of generating very short waves had been sporadically used, mostly for physical research purposes. The basis of nearly all successful methods is, of course, the triode, in one form or another.

There are two forms of circuit suitable for the generation of very short waves by means of the triode valve: First, the reaction circuit, and, secondly, the "electron-oscillation" circuit. With care, the reaction type of circuit may be used to generate wavelengths down to 1 metre in length, but the power available and the efficiency falls off rapidly below 2 metres. This is because the period of oscillation (1/f) is comparable with the time of transit of the electrons within the valve, so that it becomes impossible to ensure that there shall be the correct phase relationship between the electrode voltages and currents according to standard valve-oscillator theory to give normal efficiency.

To generate wavelengths shorter than a metre in length, use must be made of the natural period of flight of the electrons between the valve elec-

¹Ref. recent talk before the Royal Institution by Marchese Marconi.

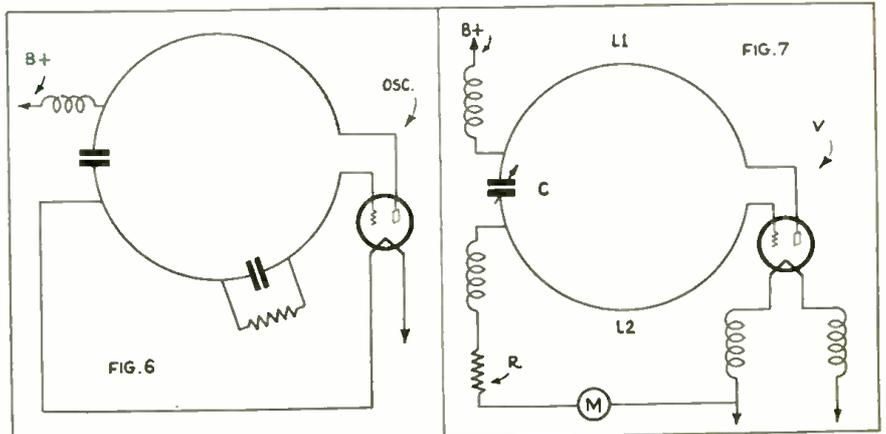

Fig. 6—An early single tube short-wave circuit of symmetrical form. Fig. 7—A later version of the circuit shown in Fig. 6.

Ultra Short Waves

This study of ultra-short-wave generators is particularly vital today, when waves only 3½ inches long have been made to carry the human voice over distances of a mile and more, and a 20 mile range predicted.

trodes. This is the basis of the "electron-oscillation" methods of generating very short waves, due in the first place to Barkhausen, Kurz, Gill, and Morrell. By these means waves as short as 5 centimetres (2 inches) have been successfully generated and controlled.

Oscillation Systems

The application of reaction methods of producing ultra-short waves is very interesting in its development, and throws light upon the question of valve oscillator circuits in general.

Consider the fundamental oscillator circuit shown in Fig. 1. The coupling between the grid and anode (plate) circuits may be either by means of the interlinking magnetic fields of the two coils, the inter-electrode capacity (grid-anode) of the tube, or a combination of both. Whether this coupling is sufficient to produce oscillation will depend, among other things, upon how close to mutual resonance the two circuits are. If they are in resonance, the slightest magnetic coupling, or the small amount of electrostatic coupling represented by the inter-electrode capacity of the tube is amply sufficient to produce oscillation. Hence the "tuned plate-tuned grid" type of oscillator favored by amateur short-wave transmitters.

The circuit of Fig. 1 may be redrawn as in Fig. 2. Since the source of H.T. (high tension or plate current) contributes nothing to the sum of the H.F. potentials, we have omitted drawing it in. The two coils and tuning condensers are seen to be virtually in series, so an obvious simplification is as shown in Fig. 3, producing the well-known Hartley circuit, either "series" (Fig. 3 (a)) or "shunt" fed (Fig. 3 (b)).

Any of the types of oscillator just described may be used with success on ordinary short wavelengths (down to 5 metres), but when we wish to generate shorter waves still they are not so satisfactory. Using an ordinary large receiving tube or small transmitting tube, the lengths of the leads within the tube

may be quite as great as the length of wire forming the coil, so that, instead of having a true Hartley circuit as in Fig. 3, we have the queer arrangement shown in Fig. 4. This leads to several troubles. First, the relative amount of inductance included between the condenser terminals is small compared with the total amount of inductance in the circuit, the parts of the inductance lying without the L-C circuit acting as chokes and reducing the potentials applied to the tube electrodes. Secondly, we can trace *two coupled circuits* in Fig. 4, one being the L-C circuit, and the other the circuit via $L-11-C_{ga}-L2$. Under these conditions, when C is reduced below a certain point, it "loses control," and the second of the two circuits, that *via* the inter-electrode capacity (C_{ga}) of the tube takes charge, and the generated wavelength suddenly jumps to some value quite unrelated to the setting of the "tuning" condenser C. The combination of these effects sets a limit (round about 4 metres, usually) to the shortness of the wavelength generated by this type of circuit. It had also two further disadvantages. First, if it was shunt fed (Fig. 3 (b)), part of the self-capacity of the H.F. choke used to introduce the anode or plate feed was added to the other effective stray capacities in the circuit, since it was connected at a point of high R.F. potential; if series fed (Fig. 3 (a)), there was the damping effect of the grid leak (generally quite low in ohmic resistance, not more than 20,000 ohms) and the capacity of the grid condenser to earth, the grid condenser, in these very short-wave circuits, being a relatively "bulky" component. Secondly, in either case both sets of vanes of the tuning condenser are at a high R.F. potential relative to earth.

A Push-Pull Circuit

To overcome most of these disadvantages, the "push-pull" circuit shown in Fig. 5 and generally ascribed to R. (Continued on page 365)

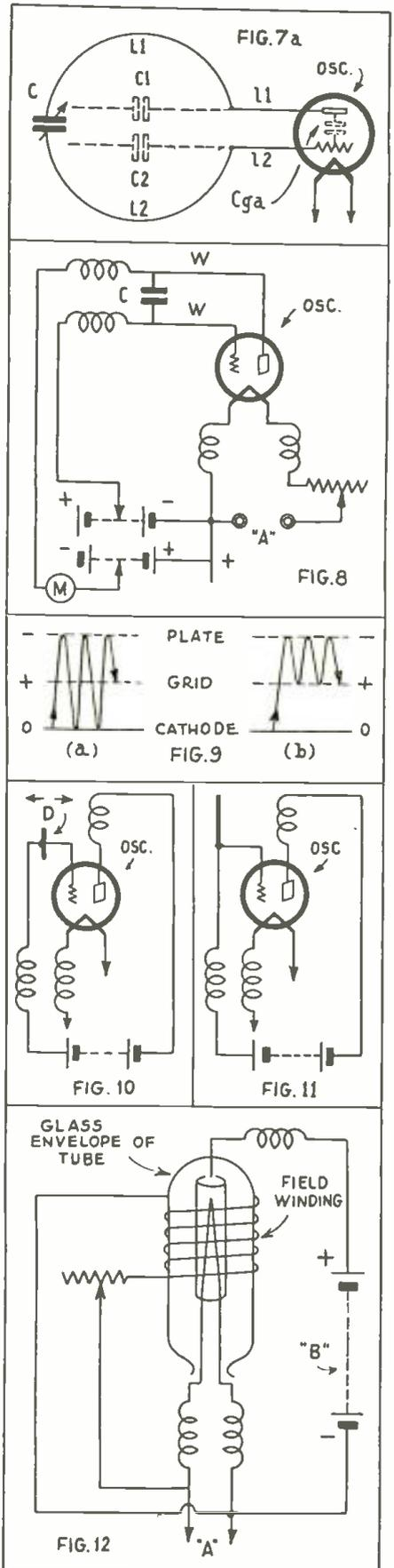

Fig. 7(a)—Equivalent of Fig. 7 with self-capacities shown. Fig. 8—"Electron oscillation" circuit. Fig. 9—Electrons may "dance" in time with oscillations. Fig. 10—Copper disc, D, arranged as a tuner. Fig. 11—A vertical wire resonator. Fig. 12—Diode with coil.

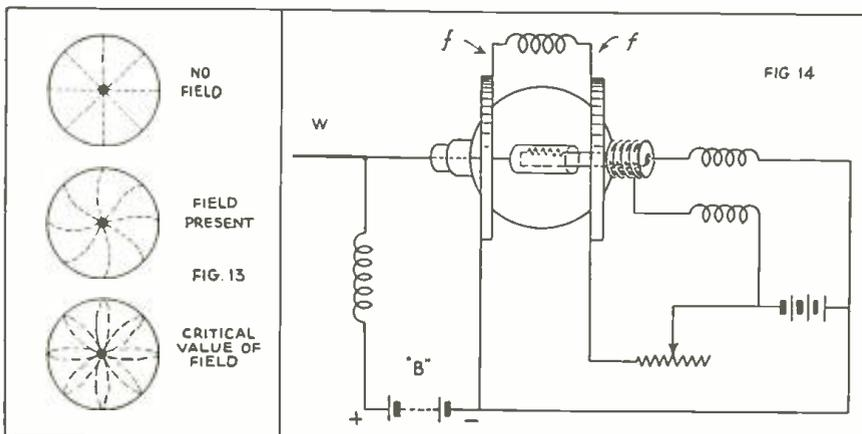

Fig. 13—Electron formation in the "Magnetron" oscillator. Fig. 14—The author's "Magnetron" arrangement with which wavelengths of from 30 to 60 cms. (12 to 24 inches) are obtainable.

WORLD-WIDE SHORT-

A Spare-Parts 5 Meter Set

(From Popular Wireless, London, England.)

RECENTLY, considerable interest was shown in 5 meter broadcasting, by British short-wave enthusiasts. A series of tests from the Crystal Palace, sponsored by Popular Wireless magazine were conducted and this receiver was built by a radio writer to listen in on the tests.

Two .00025 mf. slow-motion condensers were first dismantled and then built up again with about half the plates. The tuning condenser was given four fixed and three moving plates with double spacing. The reaction (regeneration), five fixed and four moving, with ordinary spacing. A tube socket which was considered fairly low-loss a couple of years ago, was raked up; also two 2-megohm resistors joined in series made up the grid-leak.

The R.F. choke was made from a piece of 1/2 inch ebonite (bakelite) lead-in tube, on which were wound 55 turns of number 32 enamelled wire,

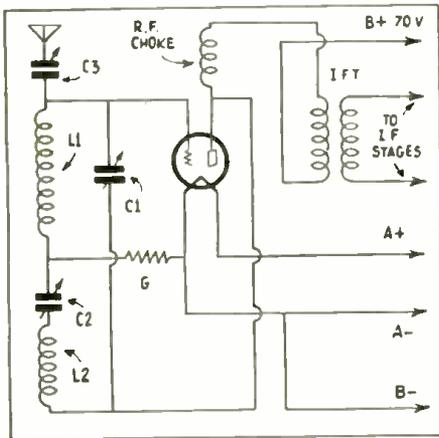

The actual 5-meter circuit is that of a combined detector-oscillator. It was coupled to a short-wave set by the "adapter" principle.

the first ten turns nearest the plate being well spaced and the remaining turns close wound.

A shallow 5-ply box about a foot square (normally used as a tray for odds and ends) formed, in an inverted position, an excellent "chassis." The condensers were mounted direct to the bottom of this by means of brass clips, thus saving the making of brackets, and positioned about six inches behind an aluminum panel. The problem of extension spindles (shafts) was solved by cutting two lengths of cane off one of the household feather dusters (fortunately not yet discovered by the domestic staff!)

The positioning of the valve holder (tube socket) and the coils was carefully considered, in order to have the wiring as short as possible. The two coils were made from 1/4 inch copper tubing which was first softened by heating and then coiled around a 1/2 inch former and sprung off. Four and a half turns comprised each coil with the turns spaced about 1/16 inch. The

The editors have endeavored to review the more important foreign magazines covering short-wave developments, for the benefit of the thousands of readers of this magazine who do not have the opportunity of seeing these magazines first-hand. The circuits shown are for the most part self-explanatory to the radio student, and wherever possible the constants or values of various condensers, coils, etc., are given. Please do not write to us asking for further data, picture-diagrams or lists of parts for these foreign circuits, as we do not have any further specific information other than that given. If the reader will remember that wherever a tuned circuit is shown, for instance, he may use any short wave coil and the appropriate corresponding tuning condenser, data for which are given dozens of times in each issue of this magazine, he will have no difficulty in reconstructing these foreign circuits to try them out.

coils were mounted direct to the condensers and about 1/4 inch apart, the ends of the windings having been left long enough to facilitate this. The choke was mounted out of the way (against possible induction interference) under the tube socket inside the chassis, and a lead taken from it to a terminal at the back of the latter. Filament leads of flex were led down through the chassis in a similar manner and then out at the back. The rest of the wiring was done with heavy gauge bare copper wire, everything being kept absolutely rigid. A .00005 mf. trimmer condenser was included in the aerial lead.

The output of this one tube unit was then coupled to the I.F. stages of a short-wave superheterodyne as a converter unit, thus giving the effect of a 5 meter superhet. The output of the single tube could have been connected directly to head phones though, with a correspondingly lower volume, of course.

Selective Band-Spreading

(From Das Funk Magazin, Berlin, Germany.)

A RATHER unusual band-spreading arrangement for short-wave receivers was described in a recent issue of Das Funk Magazin, a German radio magazine devoted mostly to short waves. The system comprised a switching arrangement which permitted the use of either normal or band-spread

reception on any part of the band, by merely throwing over a switch.

If a short-wave receiver is built with a range from 20 to 60 meters, the 40 meter band, for instance, is crowded on a small part of the scale. The illustration shows how, by merely throwing a switch over, on a normal S.W. receiver, one may get band-spreading. When the switch is placed on the left, the short-wave receiver is set for normal reception. If, however, the switch is turned to the right, the capacity of the tuning condenser is diminished by the series condenser and at the same time a parallel condenser is switched in to make up the lost capacity.

The size of the tuning condenser and the width of the band control the size of the two condensers in series with and across the main tuning condenser. They will have to be found by experiment.

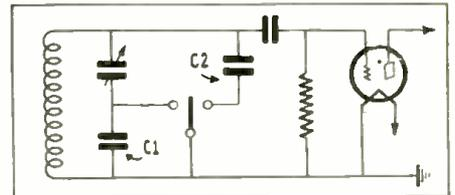

By means of the simple switch shown, either normal or "band-spread" reception may be enjoyed on any part of a band.

Simple Switching for Two Wave Ranges

(From Das Funk Magazin, Berlin, Germany.)

IN Europe, broadcasting is carried on on three different wave bands—long waves of several thousand meters; the usual broadcast band, and short waves. For this reason, their sets are ordinarily designed to cover different waves by using some form of switching. The sets used ordinarily in these countries comprise some form of regenerative circuit, using one or more stages of R.F. amplification before the detector. This usually necessitates

(Continued on page 363)

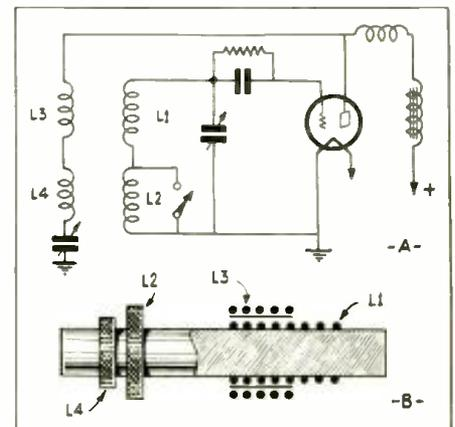

Another switching scheme for changing the wavelength to which a receiver responds (A) and (B) details of the special coil winding employed.

WAVE REVIEW

Edited by
C. W. PALMER

Direction Finding For Amateurs

(From *Wireless World*, London, England.)

● SHORT-WAVE enthusiasts in England are finding a great deal of enjoyment in a new outdoor hobby known as "transmitter hunts," in which a concealed transmitter is located by portable loop receivers. American S.W. fans who are associated with a radio club or who are acquainted with a licensed amateur will find new interest in radio through this competitive game.

Comparatively few wireless (this word is used frequently abroad) enthusiasts realize that direction finding is a pleasant and cheap hobby. Almost any set is capable of conversion for this class of work, and, alternatively, most amateurs have a collection of spare parts which can be used to build a suitable receiver.

The waveband used is from 150 to 170 meters (in U. S. this would have to be determined by the regulations of the Federal Radio Commission). A description follows of two sets which are very simple to construct and have proved satisfactory. The first is a two-valve (tube) set consisting of a leaky grid detector (grid-leak detector) with reaction (regeneration), transformer coupled to either a triode or pentode output valve (tube).

In this case, the frame aerial should consist of approximately 6 turns with 1/2 inch spacing between turns on a frame with 2 ft. sides. As will be seen from the diagram, the center tap of the frame (loop) is returned to the L.T. ("A") negative.

This set should be made inside a metal box for preference, although not essential, as this tends to eliminate direct pick-up of the signals by the wiring of the set.

It might be mentioned here that all direction finding bearings are taken on the minimum signal—i.e. with the plane of the frame aerial at right angles to the transmitting station. The small condenser A is adjusted when the approximate minimum signal is

(Continued on page 363)

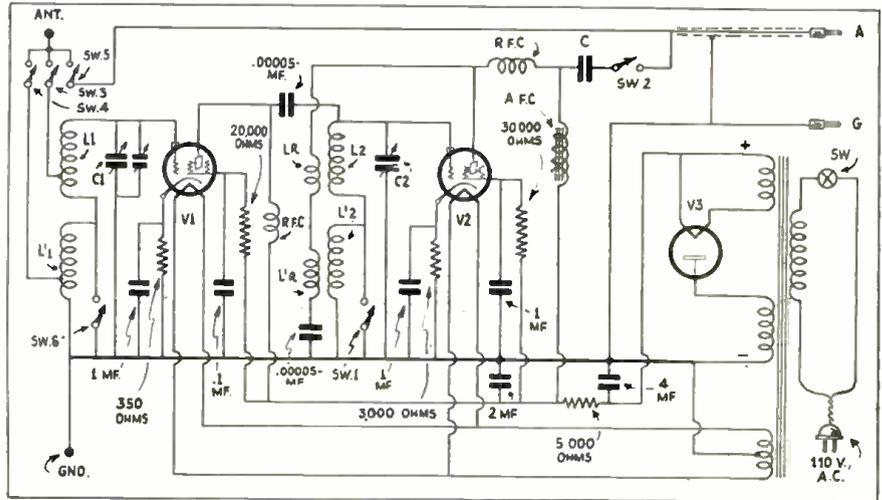

Short-wave converter hook-up having several new features, including switch for changing wave-bands.

A Superhet Converter

(From *Radio-Amateur*, Vienna, Austria.)

● THIS magazine recently described an interesting short-wave converter for making a broadcast receiver into a short-wave superheterodyne.

The unit consists of a stage of radio frequency amplification, and an autodyne type of frequency changer, as shown in the diagram. The first tube V1, is the radio frequency amplifier, V2 is the frequency changer and V3 is the rectifier tube supplying current to the plates of the other two tubes.

The coils are arranged to cover two short-wave bands, and for this purpose are divided into two parts. When the shorter waves are being tuned in, a switch is turned that automatically short-circuits part of the tuning inductance of both the R.F. tube and the frequency changer. At the same time, the aerial connection is shifted from one tap to another on the grid coil of the R.F. tube, to provide the correct amount of coupling to this tube. The same switch also provides for reception on the broadcast band, without discon-

necting the converter from the broadcast receiver. In this case, the aerial is connected directly to the broadcast set and the plate of the frequency converter is disconnected from the aerial of the set.

While the actual constructional details of this converter are probably not of interest to the American "fan," the switching arrangement can be inserted in existing converters, to advantage.

Anyone desiring to build the unit shown in the illustration will find the values of all parts on the diagram. Available coils may be substituted for those shown, and the switching of the tuning coils changed to suit. An 80 or 82 type full-wave rectifier tube will probably be preferred to the half-wave unit shown. However, the changes are obvious.

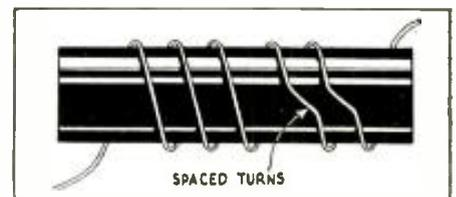

One of the latest tricks for aligning short-wave coils in "gang-tuned" circuits is to move the turns of wire on the coils as indicated, instead of using trimming condensers.

Aligning S-W Coils for Gang Control

(From *Das Funk Magazin*, Berlin Germany.)

● IF one builds a T.R.F. receiver covering several wave ranges, including also a short-wave range among them, it is not possible to equalize slight differences in the self-inductance of the short-wave coils by changing the trimmer condensers or by bending the plates of the main tuning condensers, as this would throw the circuits out of resonance on the longer waves.

Nevertheless, it is rather easy to change the self-inductance of a short-wave coil to accomplish the same re-

(Continued on page 357)

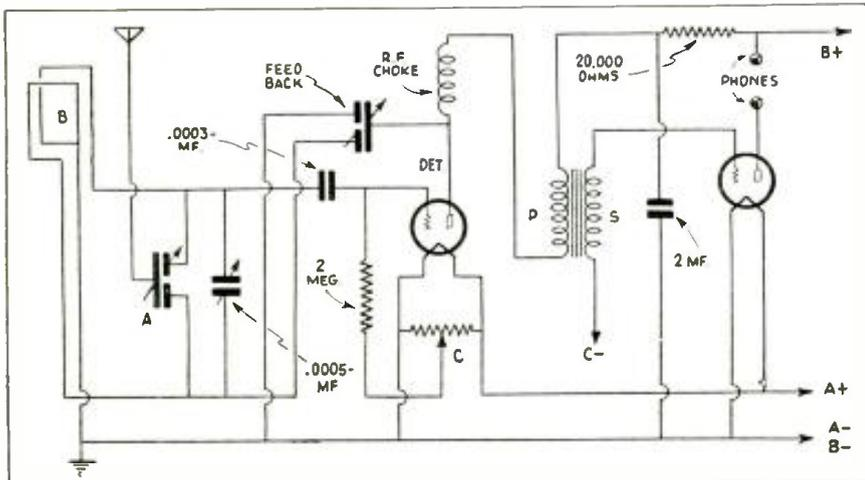

Circuit for a simple 2-tube loop receiver suitable for "direction finding" work. The detector uses a grid-leak and also regeneration, the output stage being transformer coupled.

LETTERS FROM S-W FANS

MAKES "DOERLE" WORK SPEAKER ON ALL WAVES

Editor, SHORT WAVE CRAFT:

I have been reading SHORT WAVE CRAFT since the January-February issue of 1932, and find it very interesting. I intend reading it as long as you publish it. In most every copy I find some comments on the so-called "Doerle" set. Well, I built one of them and I find that anyone who builds this set and uses good standard parts is bound to get results! I built the original 2-tube set but I soon tired of the "earphone" reception, which was about all I could get with two tubes. I undertook to make this a loud-speaker receiver. I added a pentode tube to it and now I get everything on the speaker!

It costs very little to do this as all one needs is a three-to-one audio transformer, 5-tube socket and a 33 tube; after doing this I decided to make it an all-wave receiver, which I did with very good success. The coils described with the set never got above sixty meters, so I undertook to wind some coils as follows. I bought three coil forms $1\frac{1}{2}$ " outside diameter, $2\frac{3}{4}$ " long. On the first coil I wound ten turns on the tickler, and thirty-two turns on the secondary; on the next coil I wound fifteen turns on the tickler, and fifty turns on the secondary and the last and broadcast coil—30 turns on the tickler and 110 turns on the secondary. After doing all this, I discovered that the receiver was not very selective on the higher waves. In the October issue, I saw on page 353 a diagram of an extra antenna condenser which could be cut in and out by a switch for better selectivity on the higher waves, so I inserted one of these and "believe you me" I have an all-wave receiver that can't be beat! Hi! Hi! After adding the pentode tube to the set I got a howl at the regeneration point; putting a 100,000 ohm pigtail resistor across the first audio transformer stopped that. I have had everything in the States and Canada on this set and Germany, France, England, Rome, Spain, South America and Australia—all on loud-speaker! If you publish this letter I hope it will help some of the Doerle set builders and if it does I would like to hear from some of them.

GEORGE BANNON,
3123 Hudson Ave.,
Youngstown, Ohio.

(We doff our hats and bow real low, George—you take the cake and all the medals! That was a clever idea to add the pentode tube on the Doerle so as to get "everything" on the speaker; the final master stroke of genius was shown when you made the Doerle an "all wave" receiver. We are sure that there will be a new popular wave of interest aroused in the Doerle receiver, both the 2- and 3-tube models, described in the December-January, 1932, and November, 1932, issues respectively. Fine business, O. M., let's hear from you again.—Editor.)

MEGADYNE "INHALES" DX STATIONS FOR HIM!

Editor, SHORT WAVE CRAFT:

I am a newsstand reader of SHORT WAVE CRAFT magazine and I believe it is the best short-wave magazine. I especially am interested in one and two tube sets which really can "inhale" distant stations.

I was lucky enough to procure the August (1932) issue and suddenly became interested in the Megadyne. So, I constructed the set and, at first, had little success with it. After changing the antenna and crystal detector and a few other adjustments I have received some forty-eight stations, most of these being "amateurs."

The set is constructed a little differently from your description. I used a Frost rocker-contact potentiometer, and the coil

and tube sockets are reversed in their location on the sub-panel. At present, I am using a set of Air-King plug-in coils but also have a few home-made coils. I am using ninety volts on the plate of a 38 Cunningham tube. I had difficulty in volume with the set but after changing the antenna this difficulty has been overcome.

I have an L-shaped antenna about 18 feet high at all points. One length of the antenna runs in an east and west direction, this length being 75 feet long. The branch which is about twenty-five feet long runs to the south at the west end. This branch is approximately at an 80 degrees angle to the main branch. The lead-in is about twenty feet long.

In regard to stations I have received, 43 include amateurs and four short-wave stations in the U.S. I received a foreign station, which I believe was EAQ at Madrid. All announcements were made in Spanish with the exception of the one at the closing of the program. This was made in English but I had difficulty in understanding the conversation because of an intermittent howl. The weather here in Streator was somewhat cloudy and cold. I received this station on a home-made coil, using 18 turns of No. 26 D.S.C. wire on the plate coil and 9 turns of No. 28 D.S.C. wire for the secondary coil. The form used was a tube base and a $\frac{1}{2}$ " space was left between the plate and secondary coil.

IF

YOU have a good Short-Wave Receiving Station or "Ham" Station, take a clear photo of it and send it along, with brief description. Send photo of yourself as well if you do not appear in the station photo.

Let's have more sets like the Megadyne and continue the good work in SHORT WAVE CRAFT magazine.

ANDREW CHISMAR, JR.,
1507 S. Bloomington St.,
Streator, Illinois.

(The "Megadyne" seems to have many a trick "up its sleeve," judging by the results you have obtained with it and also those recorded by the many other readers of SHORT WAVE CRAFT. Perhaps, some of you fellows will follow up this "Megadyne" circuit and develop a new high power "1-tube," by employing either the original Megadyne circuit or a modification of it, so as to utilize one of the newest pentagrid-converter tubes for example. There is a lot of research to be done in a good "one-tube" receiver, and we have a hunch that one of you boys is going to show us a very startling circuit one of these fine days. So our advice to all short-wave fans who read this, is to get busy immediately and see what you can discover along the line of a "1-tube" receiving circuit, using one of the newest tubes. Perhaps the secret of operating a loud speaker in real "loud" fashion lies in the use of one of the new power tubes.—Editor.)

"GLOBE TROTTER" GOT HIM EVERYTHING BUT A "RAISE."

Editor, SHORT WAVE CRAFT:

There are some things I must get off my chest—so here goes! I am one of the many "hams" soldering a lot of wires and gadgets together and expect to get Eng-

land, Rome and so forth. But, why worry about trying to design a circuit when you folks can do it for us. I built the "Globe Trotter" and I got everything on it but a raise in salary! The circuit is a dandy. Instead of using a .001 mf. for regeneration, I use a .00035 mf. with good results. I have built lots of circuits from the SHORT WAVE CRAFT magazine and they are all O.K.; Mister, we just couldn't get along without it.

I am constructing a "midget" set, which I hope to win a prize with from your magazine. It is 5"x5"x5" which is quite small. I will answer any questions that any of the "hams" would write to me.

L. B. HOLTZ,
1159 Brewster Avenue,
Akron, Ohio.

(We have had a lot of interesting letters concerning the "GLOBE TROTTER" but it seems you had some extra fine results with it. Yea, the "Globe Trotter" made a lot of friends and one thing about it—it's almost impossible to build a short-wave receiver "worth a ding" and composed of less parts, or using a smaller number of tubes or batteries. Glad you have found other circuits published in SHORT WAVE CRAFT quite worthwhile and "workable." Let's have a look at the midget set when you have it ready.—Editor.)

JULY NUMBER A GEM!

Editor, SHORT WAVE CRAFT:

I found the July number of SHORT WAVE CRAFT to be a "gem;" packed full of interesting articles and teeming with interest.

A. S. HUNTER, D.D.S.,
Box 311,
Durham, N. C.

(Thanks, Doctor, very much for your welcome letter; the editors are constantly aiming to make each succeeding issue of SHORT WAVE CRAFT more interesting and more valuable to each and every reader.—Editor.)

DOERLE SET "GETS" HUNDREDS OF STATIONS!

Editor, SHORT WAVE CRAFT:

I have been a reader of SHORT WAVE CRAFT ever since you started publishing it and I praise it very highly because I think it is the "swellest" magazine on the market. I built that "Doerle" two tube set described in the December-January, 1932, issue of SHORT WAVE CRAFT and it sure does work fine. I have gotten over 400 stations in a month and have all the districts except the 7th. I am hoping to pick up a cheap and dependable transmitter from someone. I am listing some short wave broadcasting stations I have received: W3XAU, W8XK, W3XL, VE9G, W9XAA, W2XAF and W9XF, etc. I wish to get in touch with someone who has a nice 20 watt job and if so, please send me the diagram. I will be glad to answer any questions regarding the Doerle set and don't be bashful, you boys.

JEROME WILLIG,
437 E. Lawson Street,
St. Paul, Minn.

(Over 400 stations in a short time and all on the Doerle 2-Tube Receiver; hot stuff!—Jerome. The editor does not recollect hearing of a 2-tube receiver which has accomplished results that could excel those achieved by short-wave "fans" all over the world with this set. You will undoubtedly find however that some of the new 1 and 2 tube sets, such as the "Oscillodyne" described by Mr. Worcester in recent numbers of SHORT WAVE CRAFT will give you plenty of thrills. The Oscillodyne certainly does a lot of things which one wouldn't expect offhand from a one or two tube set.—Editor.)
(Continued on page 378)

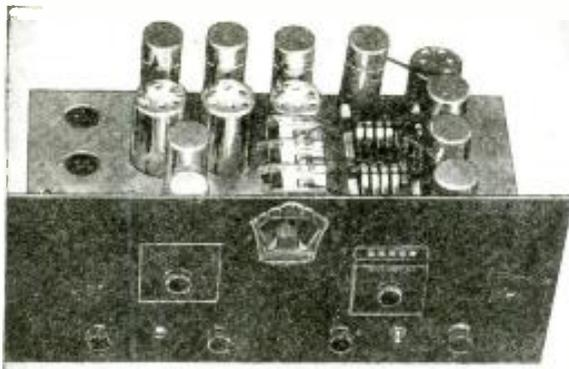

Front and top view of the 9-tube Superhet fitted with sliding "drawer" coil and switch.

9-Tube Superheterodyne Has Coil Switch

By M. S. MILLER*

Here is a well-designed 9-tube "Pro" type superhet receiver which covers the short-wave bands in four steps, with switch type "drawer" coils; it provides "band-spread" whenever desired.

● THE *Postal International* is a 9-tube short-wave professional type receiver of the genus *superheterodyne* and covers a range of 1,540 to 15,000 kilocycles in four steps. Each wave band is covered by specially designed multiformers, each set consisting of three coils individually shielded in copper compartments. The three coils for the R.F., detector, and oscillator circuits for any given band are arranged in a partitioned copper drawer or can, fitted with a bakelite top, which carries the switch contact pins arranged in rows as the picture shows. This principle of changing the coils in such a complicated circuit as the superhet, has been used in some of the commercial receivers designed and built for government service, and it therefore has a strong family tree behind it. One thing about this method of building the switch type coils is that the leads are kept short, as they should be in all short-wave receivers, and by the design of the switch springs here employed a firm and positive contact is assured at all times.

To change from one band to another all the operator has to do is to pull out one "coil drawer" and insert another,

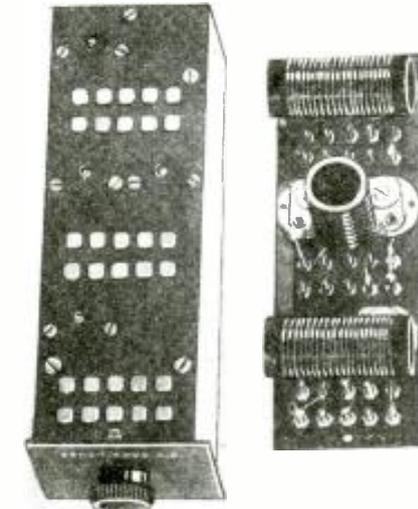

Close up of one set of coils in sliding shield box; in one position of the "drawer" "normal" tuning results—moved one half inch, "band-spread" is provided.

the front panel of each coil unit being engraved with the frequency range in K.C. to which it responds. By simply

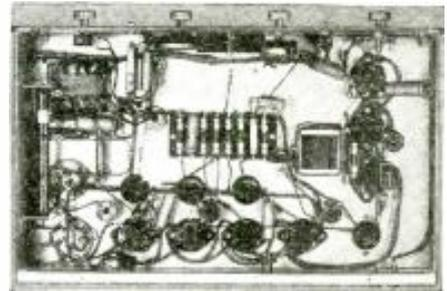

Bottom view of the 9-tube superhet.

pulling the drawer out 1/2 inch the advantage of "band-spread" tuning may be enjoyed, the band being spread over 65 degrees of the dial for example, in all of the four amateur bands.

A tuned radio frequency amplifier stage is used ahead of the first detector, which helps to eliminate repeat spots or image-frequency interference found in many superhet receivers. The variable condenser connected in series with the antenna circuit, coupled to the grid of the R.F. amplifier stage, makes it possible to match the R.F. and first detector tuning circuits, so that they will track accurately.

*Engineer, Postal Radio Corp.
(Continued on page 362)

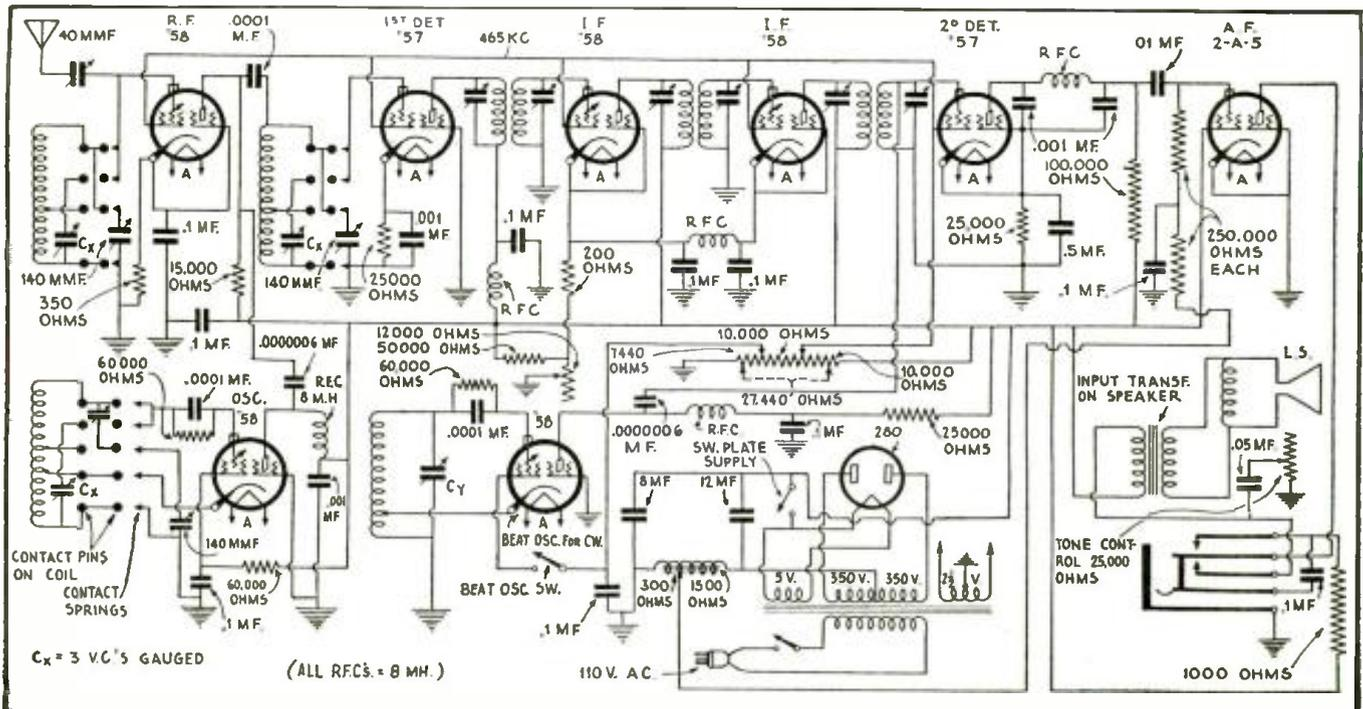

Diagram of connections used in the Postal International 9-Tube Superhet. All three coils, R.F., detector, and oscillator, are simultaneously changed in one single operation from the front panel, by a simple one-half inch movement of the complete coil shield box or "drawer"; the set being converted from ordinary tuning to band-spread tuning in a jiffy. The bands are spread over 65 degrees of the dial.

SHORT WAVE LEAGUE



HONORARY MEMBERS

Dr. Lee de Forest
 John L. Reinartz
 D. E. Replogle
 Hollis Baird
 E. T. Somerset
 Baron Manfred von Ardenne
 Hugo Gernsback
Executive Secretary

A Few "Hot" Opinions From Our Readers

"CQ." Club Wants Code Test

Editor, SHORT WAVE CRAFT:

At the last regular meeting of this club a resolution was passed that this organization go on record as protesting against that part of your program in which you foster the elimination of the code test for all below six meters. Our experience has been that the harder it is to secure a license, the more it is appreciated. In fact, there are too many amateurs on the air now who do not have sufficient knowledge of radio fundamentals to properly operate their stations.

If the bars were let down in this particular case, it would not be long before the amateur bands were so crowded with beginners that the regular "ham" would not have room to handle his traffic. We believe in encouraging the beginner in every way possible, but if he is "worth his salt" at all he will learn the code so he can take his place among the other amateurs.

We are in favor of leaving the requirements stand as they now read, and are prepared to give our entire strength and influence to that cause.

CQ CLUB,

A. C. Brown, Jr., Secretary,
 60 North 63rd Street, Philadelphia, Pa.

No Code Below 6 Meters!

Editor, SHORT WAVE CRAFT:

I have been reading your magazine for a number of years and can say I have found no better. I would like very much to become a member of your League, because I believe your aims are to be encouraged and upheld. I also believe if the "five meter" band were open to persons who could obtain licenses *without the code test*, there would be a greater amount of interest shown in ultra short waves—therefore more experimenting, and further development of this so-called "back yard band."

Understand, I do not say code should be abolished in *all* bands; heaven forbid! There are enough "rotten" operators on the air to prove that. Keep the same standards or even make them higher and I feel there will be a greater respect shown to the amateur radio game.

I believe that if code is done away with below six meters, there should be given a test on the technical part, so thorough that when the prospective operator could qualify he would be able to operate a station that would be in all respects a "true ham station."

In one way the code is a barrier to greater experimenting, as I have found out myself. I was one who thought that code was not important. After failing the "exam" once, I got busy and am now a full-fledged amateur.

All it takes is a little work, and if some who would like to become amateurs would study the code, they would learn it in the

same length of time it takes them to condemn and talk about how hard it is. I've tried it and know. Nevertheless, there would be a great deal more experimenting below six meters here in college, if it were not for the "code test."

I hope I have made myself plain. Here is my argument: No code below six meters, but a thorough exam; code in the other bands.

Jack Gardner, W9GJE
 Dept. of Physics
 Western Kentucky Teachers College
 Bowling Green, Ky.

A Voice From Minnesota

Editor, SHORT WAVE CRAFT:

I have been reading the letters in your magazine from fans and fellow members of

living any place where the "grand old mag" travels.

Bob Snow,
 Grand Rapids, Minn.

He's for Phone "Ticket"—Less Code

Editor, SHORT WAVE CRAFT:

I've been reading, nay "studying" SHORT WAVE CRAFT for a long time and also want to comment upon your proposed "phone" league. Your views are commendable.

Why should everyone be compelled to learn to "pound brass" to obtain a government license? I owned a short-wave station W8GSU, and I know that after the inconvenience of learning the code, I never had but one occasion to use it and therefore believe that the code should be optional.

Do the "brass pounders" think that either because of their intense desire to send C.W. or "lack of funds" or ambition to procure the additional equipment to make a phone station, that the rest of us should be compelled to handle a key?

I am a very busy service man and my hobby is to develop quality in various equipments for phone work or P.A. systems.

The C.W. bugs in this town develop terrific thumps and snaps and crackles in the B.C. set while the phone men are rarely ever guilty of causing even minor disturbances.

This phone work as required by the F.R.C. demands high-grade equipment, using M.O.P.A. or similar design and requires ordinarily a very different knowledge of radio. Anyone can rig up an oscillator or an osc.-amp, and zig-zag out into space.

More power to you, Mr. Gernsback. Go to it and we'll show the old "brass pounders" some real phone business.

I'm willing to be instrumental in forming local chapters of such an organization and such an organization will be recognized by the F.R.C. as there undoubtedly is plenty of room for both phone and CW in the ether, with no interference from either.

I've no quarrel with "C.W.," mind you, but when "brass rules phone"—or so attempts. Oh! Oh! One man's liberty ends where it begins to tread upon his fellow man!

J. O. Roberts,
 102 W. Saginaw,
 St. Louis, Mich.

(We shall be pleased to have your opinion regarding the "code-less" license for transmitters operating below five meters. We shall also be very glad to receive some constructive suggestions from our readers as to new subjects they would like to have discussed or presented in this department. —Editor.)

Get Your Button!

The illustration herewith shows the beautiful design of the "Official" Short Wave League button, which is available to everyone who becomes a member of the Short Wave League.

The requirements for joining the League are explained in a booklet, copies of which will be mailed upon request. The button measures 3/4 inch in diameter and is inlaid in enamel—3 colors—red, white, and blue.

Please note that you can order your button AT ONCE—SHORT WAVE LEAGUE supplies it at cost, the price, including the mailing, being 35 cents. A solid gold button is furnished for \$2.00 prepaid. Address all communications to SHORT WAVE LEAGUE, 96-98 Park Place, New York.



the SHORT WAVE LEAGUE but I did not see one from a representative in this northern Minnesota country. I "tinkered" with radios some years ago but gave it up. Then, thanks to SHORT WAVE CRAFT I took it up again. One little set that brings in the stations is the "Old Reliable" described in the March issue. I have received EAQ and GSB with a "sock," South American stations most any night, and Honolulu whenever they are on; all with "verifications." I am trying to master the old "dot and dash" code so I can soon be "on the air" to mess it up a little worse.

I think "S. W. C." is a swell magazine for anyone interested in radio. I'll never be without it.

I will gladly answer all letters from any other "fans," "hams," or "what have you,"

SOLDERING IRON SUPPORT
\$5.00 Prize Winner.

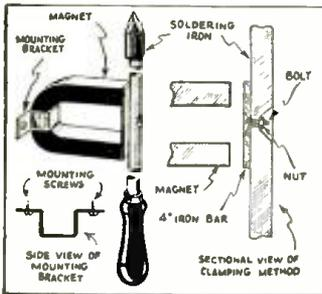

The soldering iron is a tool that always seems to be in the way, when working on radio sets. This kink offers a novel way of solving the problem. The illustration clearly shows the arrangement, but it may be well to add, that in case the soldering iron is made of iron, the small iron bar shown, of course, will not be necessary; as some irons are made of brass, etc., the magnet will not carry the iron, which calls for the use of the iron bar.

The writer obtained the steel magnet from an old cone speaker, but any good magnet will fulfill the purpose. The magnet may be mounted in any desired position. In this case it was placed on the wall right over the work bench. This kink can be used on both electric, as well as gas irons. The heat from the iron will not affect the magnet.—Henry Henriksen.

CHANGING 6 VT. BATTERY TO 2 VT.

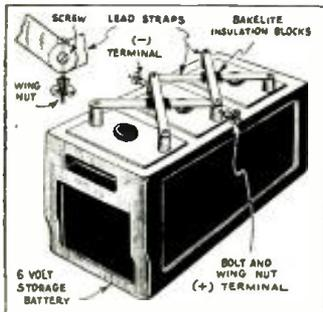

The six volt storage batteries may be easily adapted to supply the two-volt tubes by first cutting out with a hack saw the connecting straps between cells as shown in sketch. Then make four new straps of heavy lead to reach diagonally across to the three plus and three minus terminals. Then drill down into the top of each battery terminal and tap for a small machine screw; also drill holes in the ends of each of the straps. Then secure the straps to the tops of the posts as illustrated, fastening them down with brass machine screws. Drill through the two center posts to take a wing-nut. Finally solder all post connections carefully. Bakelite strips may be placed between the connecting straps to prevent a short-circuit. When charging use the two and four volt sides of the charger.—John Terceven.

BATTERY KINK

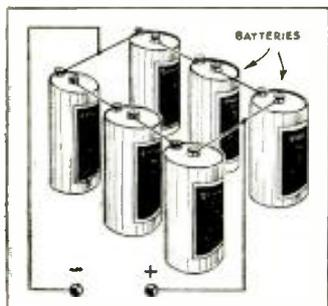

If your "A" or "B" batteries must withstand a high amperage drain there is a more economical method than connecting the cells in series and buying a new set when they are worn out. The method is to buy two sets at the same time and connect them in multiple series. They will last at least thirty per cent longer than if the two series of cells had been used consecutively.—Patrick A. Schiavone.

\$5.00 For Best Short Wave Kink

The Editor will award a five dollar prize each month for the best short-wave kink submitted by our readers. All other kinks accepted and published will be paid for at regular space rates. Look over these "kinks" and they will give you some idea of what the editors are looking for. Send a typewritten or ink description, with sketch, of your favorite short-wave kink to the "Kink" Editor, SHORT WAVE CRAFT.

AUTOMATIC LIGHTNING VALVE

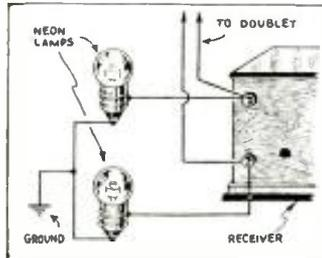

As no ground is used with the "doublet" antenna (one wire being used as a counter-pole), there must be a switch which will enable a person to "ground" the doublet antenna when not in use, especially in the summer time. The antenna should always be grounded when not in use. This device is entirely automatic, that is, it is connected across the receiver all the time and it functions whether or not the receiver is in use. It consists of two small Neon bulbs, which are mounted in a double porcelain socket. The screw action of each bulb is connected across either side of your antenna.

HOME-MADE POTENTIOMETER

By purchasing a number of different makes and sizes of ordinary lead pencils, quite serviceable rheostats and potentiometers can be made with a rotating slider arm made of spring brass arranged to slide over the graphite strip within the pencil. One side of the pencil wood being ground away or one-half of the pencil wood removed by soaking.

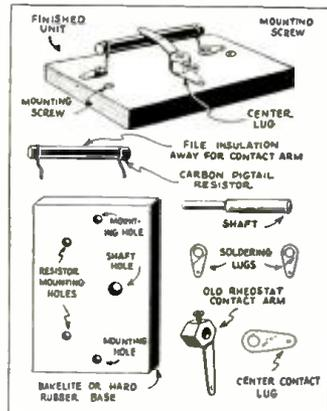

This device can be used to a great advantage and is surprisingly efficient when built correctly. Now as to the cost of construction: it runs about ten cents. To construct this "pot" first take a piece of bakelite or hard rubber about 2" x 2 1/2" and drill the holes to fit the shaft used and the resistor, which is of the carbon digital type. Next procure an old rheostat with a removable contact arm and shaft and mount on the bakelite base as shown in the drawing. Take the resistor, whether it is 1,000 or 50,000—no matter what size—and file the insulation off lengthwise, bend loops in the end and fasten down with small bolts and attach the soldering lugs. Now, if this resistor is used just to try out some new circuit which you think will be a "wow," I would advise you to buy a good volume control, as this outfit takes a very fine adjustment and covers the whole scale in about 45 degrees.—John Zoelner, Jr.

BAND-SPREAD KINK

With three plates of a condenser and a skate "toe clamp adjustment" a very good arrangement may be made to form a band-spread condenser. Use large plates; bolt the two stator plates on pieces of bakelite which in turn are fixed on a piece such as

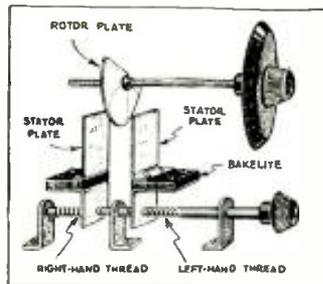

a toe clamp of a roller skate. Use the screw part to vary the distance between plates by extending a shaft on to it and a knob. If a skate "gadget" is not available a suitable arrangement may be made by threading a rod with left and right hand dies, and suitably tapping angle plates to screw on the threads.—Stuart Smith.

PHONE-SPEAKER JACK SYSTEM

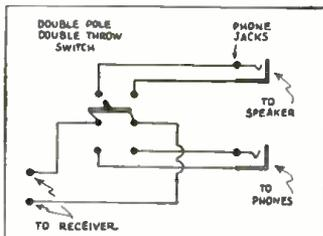

The diagram shows two phone jacks, one for "headphone" connection and the other for "loud speaker" connection. When the reception is not loud and clear for the speaker, throw the double-pole, double-throw switch to the phone position and vice-versa.—Eugene Knauss.

COATING RESISTORS

To cover unprotected carbon resistors obtain two or three old "B" batteries and remove the sealing wax that covers the top surface of the batteries. Now, place the wax in a pan or tin can and heat over a stove to melt the substance. When the wax is thoroughly melted, dip the carbon resistors in the wax.—M. Oyama.



WINDING TUBE-BASE COILS

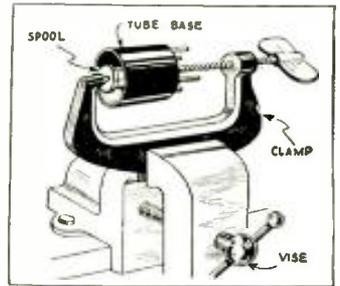

Tube-base coil forms are easily mounted for winding by means of a spool and C-clamp held in a vise as illustrated.—Alvin Falley.

CONNECTING TWO PAIRS OF PHONES

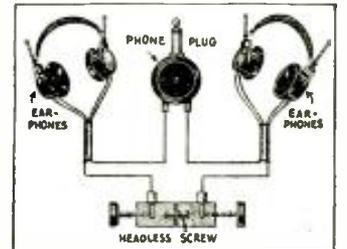

When some stray ham blows into the shark to hear your outfit perk, you hunt around, vainly seeking an elastic band to bind the phone tips together for an extra pair of phones. By joining two binding posts with a headless screw many temperamental hams have been converted into "refined gentlemen," and we are sure that this amazingly simple device will make new men of you too!—Edward S. Hill.

STAND-OFF INSULATOR

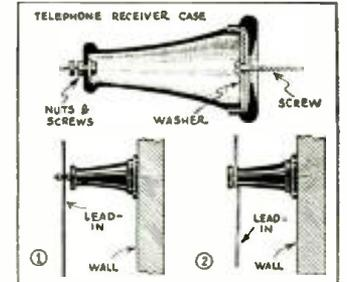

Needing a "stand-off" insulator and not having one handy, I made one from an old telephone receiver case. The cap is screwed to the wall and the other part twisted on. The wire may be hooked around the end or fastened to a nut and bolt in the hole in the end as illustrated.—Herbert Plummer.

HANDLE FOR PLUG-IN COILS

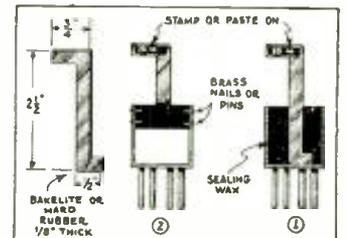

This handle protects the windings, and the coils can be plugged in with more ease. Cut a piece of bakelite as shown for each handle, pour sealing wax in the tube base, insert small end of bakelite in the base and hold in place until the wax hardens. The handle may also be pinned in place. Instead of using wax to hold it in place, it is considered the best practice to keep the inside of the coil forms empty or hollow; otherwise certain dielectric losses occur.—W. Hargett.

SHORT WAVE STATIONS OF THE WORLD

SECTION ONE

As promised in the last issue, we are presenting herewith a complete, revised and combined list of the short wave broadcasting, experimental and commercial radiophone stations of the world. This is arranged according to frequency, but the wavelength figures are also given for the benefit of readers who are more accustomed to working with "meters" than with "kilocycles." All the stations in this list, with one or two exceptions of the time stations, use telephone transmission of one kind or another and can there-

fore be identified by the average listener. The September, 1933, issue (copies mailed for 25c) contained a very fine list of police, airport and television stations, which was marked "Section Two." This will reappear in the November issue with the latest corrections and additions. Section One (this month's list) will be published again in the December issue, also with last minute changes. **Note: Stations marked with a star (*) are the most active and easily heard stations and transmit at fairly regular times.**

Stations are classified as follows: C—Commercial phone. B—Broadcast service. X—Experimental transmissions.

Around-the-Clock Listening Guide

Although short wave reception is notorious for its irregularity and seeming inconsistency (wherein lies its greatest appeal to the sporting listener), it is a good idea to follow a general schedule as far as wavelength in relation to the time of the day is concerned. The observance of a few simple rules will save the short wave fan a lot of otherwise wasted time.

From daybreak to mid-afternoon, and partic-

ularly during bright daylight, listen between 13 and 22 meters (21540 to 13000 kc.).

To the east of the listener, from about noon to 10:00 p. m., the 20-35 meter will be found very productive. To the west of the listener this same band is best from about midnight until shortly after daybreak. After dark, results above 35 meters are usually much better than during daylight. These general rules hold good whether you live in the United States or in China.

| | | | | |
|---|--|---|---|---|
| 31000 kc. W8XI 9.68 meters Westinghouse Electric SAXONBURG, PA. | 21000 kc. OKI 14.28 meters PODEBRADY, CZECHOSLOVAKIA | 19850 kc. WMI 15.10 meters A. T. & T. CO., DEAL, N. J. | 18310 kc. GAS -C- 16.38 meters General Post Office RUGBY, ENGLAND | 17770 kc. ★GSG -B- 16.88 meters British Broad. Corp. DAVENTRY, ENGLAND British Empire programs |
| 27800 kc. W6XD 10.79 meters Mackay Radio PALO ALTO, CALIF. | 20730 kc. LSY 14.47 meters BUENOS AIRES ARGENTINA Commercial radiophone | 19830 kc. FTD 15.12 meters ST. ASSISE, FRANCE | 18310 kc. FZS 16.38 meters SAIGON, INDO-CHINA 1 to 3 p. m. Sundays | 17770 kc. PHI -B- 16.88 meters HUIZEN, HOLLAND |
| 25700 kc. W2XBC 11.67 meters Radio Corp. of America NEW BRUNSWICK, N. J. | 20680 kc. LSN 14.50 meters BUENOS AIRES ARGENTINA Telephony with Europe | 19400 kc. FRO, FRE 15.45 meters ST. ASSISE, FRANCE | 18240 kc. FRO, FRE -C- 16.44 meters ST. ASSISE, FRANCE | 17640 kc. Ship. -C- 17.00 meters SHIPS Phones to Shore Work on this and higher channels |
| 24000 kc. W6XQ 12.48 meters SAN MATEO, CALIF. | 20680 kc. LSX 14.50 meters BUENOS AIRES ARGENTINA Telephony with U. S. | 19300 kc. FTM 15.55 meters ST. ASSISE, FRANCE 10 a. m. to noon | 18170 kc. CGA -C- 16.50 meters DRUMMONDVILLE, QUEBEC CANADA | 17300 kc. W8XL 17.34 meters DAYTON, OHIO |
| 21540 kc. ★W8XK -B- 13.93 meters WESTINGHOUSE ELECTRIC SAXONBURG, PA. 7 a. m.-2 p. m.; relays KDKA programs | 20680 kc. FSR 14.50 meters PARIS-SAIGON PHONE | 19240 kc. DFA 15.58 meters NAUEN, GERMANY | 18100 kc. GBK -C- 16.57 meters General Post Office BODMIN, ENGLAND | 17300 kc. W6XAJ 17.34 meters OAKLAND, CALIF. |
| 21470 kc. GSH -B- 13.97 meters BRITISH BROAD. CORP. Daventry, England British Empire programs | 20620 kc. PMB -C- 14.54 meters Bandoeng, Java 3:10-4:10 a. m.; 8:9:20 a. m. | 19220 kc. WNC 15.60 meters A. T. & T. CO., DEAL, N. J. Transoceanic radiophone | 18050 kc. KQJ 16.61 meters BOLINAS, CALIF. Transpacific radiophone | 17300 kc. W9XL 17.34 meters ANOKA, MINN. |
| 21420 kc. W2XDJ 14.00 meters A. T. & T. CO., DEAL, N. J. Experimental radiophone | 20140 kc. DWG 14.89 meters NAUEN, GERMANY Tests 10 a.m.-3 p. m. | 18820 kc. PLE -C- 15.94 meters BANDOENG, JAVA. Tues. 6-8:00 p. m.; Wed. 3:30 a. m. | 17850 kc. PLF 16.80 meters BANDOENG, JAVA ("Radio Malabar") | 17110 kc. WOO -C- 17.52 meters A. T. & T. CO., DEAL, N. J. Transoceanic radiophone |
| 21400 kc. WLO 14.01 meters A. T. & T. CO. Lawrenceville, N. J. Transoceanic phone | 19950 kc. LSG 15.03 meters BUENOS AIRES ARGENTINA | 18620 kc. GBJ 16.10 meters General Post Office BODMIN, ENGLAND Telephony with Montreal | 17850 kc. W2XAO 16.80 meters Radio Corp. of America NEW BRUNSWICK, N. J. | 17110 kc. W2XDO 17.52 meters A. T. & T. Co. OCEAN GATE, N. J. |
| 21130 kc. LSM 14.15 meters BUENOS AIRES, ARGENTINA Commercial radiophone | 19950 kc. DIH 15.03 meters NAUEN, GERMANY | 18620 kc. GAU -C- 16.11 meters General Post Office RUGBY, ENGLAND | 17830 kc. PCV -C- 16.82 meters KOOTWIJK, HOLLAND 6:00-9:00 a. m. | 17080 kc. GBC -C- 17.55 meters RUGBY, ENGLAND |
| 21020 kc. LSN 14.27 meters BUENOS AIRES, ARGENTINA Commercial radiophone | 19906 kc. LSG -C- 15.07 meters BUENOS AIRES ARGENTINA 10:30 a. m.-3:30 p. m. Commercial radiophone | 18370 kc. PMC 16.33 meters BANDOENG, JAVA. | 17780 kc. W3XAL -B- 16.87 meters NATIONAL BROAD. CO. Bound Brook, N. J. 12:30-6:30 p. m., exc. Sat. and Sun. Relays WJZ | 16300 kc. PCL -C- 18.40 meters KOOTWIJK, HOLLAND Works with Bandoeng from 7 a. m. |
| | | 18350 kc. WLA -C- 16.35 meters LAWRENCEVILLE, N. J. | | |

Short Wave Stations of the World

16300 kc. WLO
-C- 18.40 meters
A. T. & T. CO., LAWRENCEVILLE, N. J.

16200 kc. FZR
-C- 18.50 meters
SAIGON, INDO-CHINA
Radiophone to Paris

16150 kc. GBX
-C- 18.56 meters
RUGBY, ENGLAND

16060 kc. *NAA
18.68 meters
U. S. NAVY, ARLINGTON, VA.
Time signals, 11:57 to noon

15950 kc. PLG
18.80 meters
BANDOENG, JAVA
Afternoons.

15860 kc. FTK
-C- 18.90 meters
ST. ASSISE, FRANCE

15490 kc. J1AA
-X- 19.36 meters
Mornings
JAPAN

15330 kc. *W2XAD
-B- 19.56 meters
GENERAL ELECTRIC CO.
Schenectady, N. Y.
Relays WGY, Mon., Wed., Fri.,
3-4 p. m.; Sun., 2-4 p. m.

15270 kc. *W2XE
-B- 19.65 meters
COLUMBIA BROAD. SYS.
Wayne, N. J.
10 a. m.-Noon

15240 kc. *FYA
-B- 19.68 meters
"RADIO COLONIAL"
Pontoise (Paris), France
Service de la Radiodiffusion,
103 Rue de Grenelle, Paris
8-11 a. m.

15210 kc. *W8XK
-B- 19.72 meters
WESTINGHOUSE ELECTRIC &
MFG. CO.
Saxonburg, Pa.
10 a. m.-4:15 p. m.
Relays KDKA

15200 kc. *DJB
-B- 19.73 meters
ZEESEN, GERMANY
7:55 a. m.-4:30 p. m.

15140 kc. *GSF
-B- 19.81 meters
BRITISH BROAD. CORP.
Daventry, England
British Empire programs

15120 kc. *HVJ
-B- 19.83 meters
VATICAN CITY
Rome, Italy
Daily 5:00 to 5:15 a. m.

15120 kc. J1AA
-C- 19.83 meters
TOKIO, JAPAN
Irregular, early morning.

15000 kc. CM6XJ
19.99 meters
CENTRAL TINUCUR, CUBA
Irregular

14620 kc. XDA
20.50 meters
TRENDS-NEWS AGENCY
Mexico City
2:30-3 p. m.

14530 kc. LSA
20.65 meters
BUENOS AIRES, ARGENTINA

14460 kc. GBW
-C- 20.75 meters
Rugby, England

14420 kc. VPD
20.80 meters
SUVA, FIJI ISLANDS

14150 kc. KKZ
21.17 meters
BOLINAS, CALIF.

13390 kc. WMA
-C- 22.38 meters
A. T. & T. CO.,
LAWRENCEVILLE, N. J.

12850 kc. W2XCU
23.35 meters
AMPERE, N. J.

12850 kc. W9XL
23.35 meters
ANOKA, MINN.,

12820 kc. *CNR
-B, C- 23.38 meters
DIRECTOR GENERAL
Telegraph and Telephone
Stations, Rabat, Morocco

12780 kc. GBC
-C- 23.46 meters
RUGBY, ENGLAND

12290 kc. GBU
-C- 24.41 meters
RUGBY, ENGLAND

12250 kc. FTN
-C- 24.46 meters
ST. ASSISE (PARIS), FRANCE
Works Buenos Aires, Indo-
China and Java.

12250 kc. PLM
-C- 24.46 meters
BANDOENG, JAVA

12150 kc. GBS
-C- 24.68 meters
RUGBY, ENGLAND

12150 kc. FQO, FQE
24.68 meters
ST. ASSISE, FRANCE

12045 kc. *NAA
24.89 meters
ARLINGTON, VA.
Time signals, 11:57 to noon.

12045 kc. *NSS
24.89 meters
ANNAPOLIS, MD.
Time signals, 9:57-10 p. m.

12000 kc. FZG
24.98 meters
SAIGON, INDO-CHINA
Time signals, 2-2:05 p. m.

11945 kc. KKQ
25.10 meters
BOLINAS, CALIF.

11905 kc. *FYA
-B- 25.16 meters
"RADIO COLONIAL"
Pontoise, Paris
11:15 a. m.-1:15 p. m.

11870 kc. *W8XK
-B- 25.26 meters
WESTINGHOUSE ELECTRIC
East Pittsburgh, Pa.
4:30-10:00 p. m.
Relays KDKA programs

11865 kc. *GSE
-B- 25.28 meters
British Broad. Corp.
DAVENTRY, ENGLAND
British Empire programs

11830 kc. *W2XE
-B- 25.36 meters
COLUMBIA BROADCASTING
SYS., Wayne, N. J.
2:00-4:00 p. m. Relays WABC

11810 kc. *I2RO
-B- 25.4 meters
"RADIO ROMA NAPOLI"
Rome, Italy
Daily, 11:30 a. m. to 12:15 p. m.
and 1:15-6 p. m.
Woman announcer

11790 kc. W1XAL
25.45 meters
BOSTON, MASS.

11760 kc. XDA
25.50 meters
TRENDS-NEWS AGENCY
Mexico City

11760 kc. *DJD
-B- 25.50 meters
ZEESEN, GERMANY
10 a. m.-6 p. m.

11750 kc. *GSD
-B- 25.53 meters
BRITISH BROAD. CORP.
Daventry, England
British Empire programs

11730 kc. PHI
25.57 meters
HUIZEN, HOLLAND

11720 kc. *VE9JR
-B- 25.6 meters
WINNIPEG, C.,NADA

11705 kc. *FYA
-B- 25.6 meters
"RADIO COLONIAL"
Pontoise (Paris)
3-5 p. m.; 6-11 p. m.
Daily

11690 kc. *YVQ
25.65 meters
MARACAY, VENEZUELA
(Also broadcasts occasionally)

11670 kc. KIO
-C- 25.68 meters
KAHUU, HAWAII

11530 kc. CGA
26.00 meters
DRUMMONDVILLE, CANADA

11490 kc. GBK
-C- 26.10 meters
BODMIN, ENGLAND

11470 kc. IBDK
26.15 meters
S.S. "ELETTRA"
Marconi's yacht

11435 kc. DHC
26.22 meters
NAUEN, GERMANY

11340 kc. DAN
26.44 meters
NORDEICH, GERMANY
Time signals, 7 a. m., 7 p. m.
Deutsche Seewarte, Hamburg

11181 kc. *CT3AQ
-B- 26.83 meters
FUNCHAL, MADEIRA
Tues., Thurs., 5:00-6:30 p. m.
Sunday, 10:30 a. m.-1:00 p. m.

10980 kc. ZLW
-C- 27.30 meters
WELLINGTON, N. Z.
Tests 3-8 a. m.

10630 kc. PLR
28.20 meters
BANDOENG, JAVA
Works with Holland and France
weekdays from 7 a. m.; some-
times after 9:30

10540 kc. WOK
-C- 28.44 meters
A. T. & T. CO.,
LAWRENCEVILLE, N. J.
Transoceanic radiophone

10520 kc. VLK
-C- 28.51 meters
SYDNEY, AUSTRALIA

10410 kc. PDK
-C- 28.80 meters
KOOTWIJK, HOLLAND
7:30-9:40 a. m.

10410 kc. KES
-X- 28.80 meters
BOLINAS, CALIF.

10410 kc. LSY
-C- 28.80 meters
BUENOS AIRES, ARGENTINA

10390 kc. GBX
-C- 28.86 meters
RUGBY, ENGLAND

10350 kc. LSX
-X- 28.98 meters
BUENOS AIRES, ARGENTINA

10150 kc. DIS
29.54 meters
NAUEN, GERMANY
Press (code) daily; 6 p. m.,
Spanish; 7 p. m., English; 7:50
p. m., German; 2:30 p. m.,
English; 5 p. m., German.
Sundays: 6 p. m., Spanish; 7:50
p. m., German; 9:30 p. m.,
Spanish

10000 kc.
30 meters
BELGRADE, JUGO-SLAVIA

9950 kc. GCU
-C- 30.15 meters
RUGBY, ENGLAND

9890 kc. LSN
-C- 30.30 meters
BUENOS AIRES
Phone to Europe

9870 kc. J1AA
-X- 30.4 meters
TOKIO, JAPAN
4-7 a. m., irregularly

9860 kc. *EAQ
-B- 30.4 meters
TRANSRADIO ESPANOLA
Alcala 43-Madrid, Spain
(P. O. Box 951)
5:30-7:00 p. m. daily

9790 kc. GCW
-C- 30.64 meters
RUGBY, ENGLAND

9750 kc. WOF
30.75 meters
LAWRENCEVILLE, N. J.

9640 kc. HSP2
31.10 meters
BROADCASTING SERVICE
Post and Telegraph Department
Bangkok, Siam
9-11 a. m., daily

9600 kc. *CT1AA
-B- 31.25 meters
LISBON, PORTUGAL
Tues. and Friday, 4:30-7:00
p. m.

9600 kc. LQA
31.25 meters
BUENOS AIRES

9600 kc. LGN
31.23 meters
BERGEN, NORWAY

9600 kc. *XETE
-B- 31.25 meters
MEXICO CITY, MEX.
2:30-5:30 p. m., 6:30 p. m.-
12 midnight

9595 kc. *HBL
-B- 31.27 meters
League of Nations
GENEVA, SWITZERLAND
5:30-6:15 p. m., Saturdays

9590 kc. *VK2ME
-B- 31.28 meters
AMALGAMATED WIRELESS,
Ltd., Sydney, Australia
Sun., 12:30-2:30 a. m., 4:30-8:30
a. m.; 9:30-11:30 a. m.

9590 kc. *HBL
-B- 31.27 meters
League of Nations,
GENEVA, SWITZERLAND
Sundays, 5-5:45 p. m.

9585 kc. *GSC
-B- 31.29 meters
BRITISH BROAD. CORP.
Daventry, England
British Empire programs

9580 kc. *W3XAU
-B- 31.32 meters
BYBERRY, PA.
relays WCAU

9570 kc. *W1XAZ
-B- 31.35 meters
WESTINGHOUSE ELECTRIC &
MFG. CO.
Springfield, Mass.
6 a. m.-midnight, daily

9560 kc. *DJA
-B- 31.38 meters
REICHSPOSTZENTRALAMT
11-15 Schoenberge Strasse
(Berlin)
3:00-9:00 p. m., Germany

9530 kc. *W2XAF
-B- 31.48 meters
GENERAL ELECTRIC CO.
Schenectady, N. Y.
Relays WGY programs
6:45 p. m.-1 a. m.

9510 kc. *GSB
-B- 31.55 meters
BRITISH BROAD. CORP.
Daventry, England
British Empire programs

9510 kc. *VK3ME
31.55 meters
AMALGAMATED WIRELESS,
Ltd.
G. P. O. Box 1272L, Melbourne,
Australia
Wed., 5:00-6:30 a. m., Saturday,
5:00-7:00 a. m.

Short Wave Stations of the World

| | | | |
|---|---|---|---|
| <p>9490 kc. SR1 -B- 31.6 meters POZNAN, POLAND Tues., 1-3 p. m. Wed., 6-7 a. m. Thurs., 1-2:30 p. m.</p> | <p>8630 kc. WOO 34.74 meters OCEAN GATE, N. J.</p> | <p>7230 kc. DOA 41.46 meters DOEBERITZ, GERMANY Irregular</p> | <p>6270 kc. HKC 47.81 meters BOGOTA, COLOMBIA 8:30-11:30 p. m.</p> |
| <p>9375 kc. EH90C 32.00 meters BERNE, SWITZERLAND 3-5:30 p. m.</p> | <p>8630 kc. W2XDO 34.74 meters OCEAN GATE, N. J.</p> | <p>7150 kc. HJ4ABB 41.6 meters MANIZALES, COLOMBIA Sat., 11 p. m.-Midnight</p> | <p>6250 kc. ★CN8MC 48 meters CASABLANCA, MOROCCO Monday, 3:00-4:00 p. m. Tuesday, 7:00, 8:00 a. m. and 3:00-4:00 p. m.</p> |
| <p>9330 kc. CGA -C- 32.15 meters 6 p. m.-6 a. m. DRUMMONDVILLE, CANADA</p> | <p>8570 kc. WOO -C- 35.02 meters OCEAN GATE, N. J.</p> | <p>6976 kc. EAR110 43 meters MADRID, SPAIN Tues., Sat., 5:30 p. m.</p> | <p>6243 kc. HKD 48.05 meters BARRANQUILLA, COLOMBIA</p> |
| <p>9310 kc. GBC -C- 32.22 meters RUGBY, ENGLAND</p> | <p>8450 kc. PRAG 35.50 meters PORTO ALEGRE, BRAZIL 8:30-9:00 a. m.</p> | <p>6860 kc. KEL -C- 43.70 meters BOLINAS, CALIF. Transpacific Radiophone</p> | <p>6167 kc. XIF 48.65 meters MEXICO CITY, MEXICO</p> |
| <p>9280 kc. GCB -C- 32.33 meters RUGBY, ENGLAND</p> | <p>8120 kc. PLW -C- 36.92 meters BANDOENG, JAVA</p> | <p>6860kc. Radio Vitus 43.70 meters PARIS, FRANCE 4-11 a. m., 3 p. m.</p> | <p>6147 kc. ★VE9CL 48.8 meters WINNIPEG, CANADA 7:00-9:30 p. m.</p> |
| <p>9230 kc. FLJ 32.50 meters PARIS, FRANCE (Eiffel Tower). Time signals 2:56 a. m. and 2:56 p. m.</p> | <p>8036 kc. CNR -B- 37.33 meters RABAT, MOROCCO Sunday, 2-4 p. m.</p> | <p>6840 kc. CFA 43.80 meters DRUMMONDVILLE, CANADA</p> | <p>6140 kc. ★W8XK -B- 48.86 meters WESTINGHOUSE ELECTRIC & MFG. CO. Saxonburg, Pa. Relays KDKA programs, 4:30 p. m.-midnight</p> |
| <p>9200 kc. GBS 32.61 meters RUGBY, ENGLAND Transatlantic phone</p> | <p>7390 kc. DOA 37.80 meters DOEBERITZ, GERMANY 1 to 3 p. m. Reichpostzentramt, Berlin</p> | <p>6753 kc. WOA -C- 44.40 meters LAWRENCEVILLE, N. J.</p> | <p>6075 kc. ★OX Y 49.4 meters SKAMLEBOAEK, DENMARK Irregular, 2:00-6:30 p. m.</p> |
| <p>9020 kc. GCS -C- 33.26 meters RUGBY, ENGLAND</p> | <p>7890 kc. VPD 38.00 meters SUVA, FIJI ISLANDS</p> | <p>6660 kc. F8KR 45 meters CONSTANTINE, ALGERIA</p> | <p>6072 kc. UOR2 -X- 49.41 meters VIENNA, AUSTRIA Tues. and Thurs., 8:30 a. m.- 4 p. m.</p> |
| <p>8928 kc. TGX 33.50 meters GUATEMALA CITY, C. A.</p> | <p>7880 kc. J1AA -C- 38.07 meters TOKIO, JAPAN</p> | <p>6515 kc. WOO 46.05 meters DEAL, N. J.</p> | <p>6069 kc. VE9CS 49.43 meters VANCOUVER, B. C., CANADA Fri., 12:30-1:45 a. m.; Sun., 12 noon-12 midnight</p> |
| <p>8872 kc. NPO 33.81 meters CAVITE (MANILA) Philippine Islands Time signals 9:55-10 p. m.</p> | <p>7830 kc. PDV 38.30 meters KOOTWIJK, HOLLAND After 9 a. m.</p> | <p>6438 kc. REN 46.6 meters MOSCOW, U. S. S. R.</p> | <p>6060 kc. ★W8XAL 49.50 meters CROSLEY RADIO CORP. Cincinnati, O. Relays WLW</p> |
| <p>8872 kc. ★NAA 33.81 meters ARLINGTON, VA. Time signals 9:57-10 p. m., 2:57-3 p. m.</p> | <p>7799 kc. HBP -B- 38.47 meters LEAGUE OF NATIONS, GENEVA, SWITZERLAND Saturdays, 5:30-6:15 p. m.</p> | <p>6425 kc. W9XL 46.70 meters ANOKA, MINN.</p> | <p>6060 kc. ★W3XAL 49.50 meters BYBERRY, PA. Relays WCAU, Philadelphia</p> |
| <p>8850 kc. W2XCU 34.68 meters AMPERE, N. J.</p> | <p>7770 kc. FTF 38.60 meters ST. ASSISE, FRANCE</p> | <p>6425 kc. ★W3XL -B- 46.70 meters NATIONAL BROADCASTING CO. Bound Brook, N. J.</p> | <p>6060 kc. CMCI 49.5 meters HAVANA, CUBA 9:00-11:00 p. m.</p> |
| <p>8850 kc. W8XAG 34.68 meters DAYTON, OHIO</p> | <p>7770 kc. PCK -C- 38.60 meters KOOTWIJK, HOLLAND 9 a. m. to 7 p. m.</p> | <p>6425 kc. VE9BY 46.7 meters LONDON, ONTARIO, CANADA</p> | <p>6060 kc. ★W3XAU 49.50 meters BYBERRY, PA. Relays WCAU, Philadelphia</p> |
| <p>8850 kc. VE9BY 34.68 meters LONDON, ONTARIO, CANADA</p> | <p>7660 kc. FTL 39.15 meters ST. ASSISE, FRANCE</p> | <p>6425 kc. ★YV1BC -B- 49.02 meters CARACAS, VENEZUELA 10:30 a. m.-1 p. m.; 5:15- 10:00 p. m., nightly</p> | <p>6060 kc. ★GSA 49.58 meters BRITISH BROAD. CORP. Davenport, England British Empire programs</p> |
| <p>8850 kc. W4XG 34.68 meters MIAMI, FLA.</p> | <p>7520 kc. CGE 39.74 meters CALGARY, CANADA Testing, Tues., Thurs.</p> | <p>6110 kc. VE9CG 49.10 meters CALGARY, ALTA., CANADA</p> | <p>6110 kc. VUC -B- 49.1 meters CALCUTTA, INDIA 9:30 a. m.-12 noon, except Fri. and Sat.</p> |
| <p>8650 kc. W3XX 34.68 meters WASHINGTON, D. C.</p> | <p>7460 kc. YR 40.20 meters LYONS, FRANCE Daily except Sun., 10:30 to 1:30 a. m.</p> | <p>6382 kc. HC1DR 47.00 meters QUITO, ECUADOR 8-10 p. m.</p> | <p>6335 kc. VE9AP 47.35 meters DRUMMONDVILLE, CANADA</p> |

Short Wave Stations of the World

| | | | | |
|--|---|--|---|---|
| <p>6040 kc. PK3AN 49.67 meters SOURABAYA, JAVA 6-9 a. m.</p> | <p>6000 kc. EAJ25 50 meters BARCELONA RADIO CLUB, BARCELONA, SPAIN 3-4 p. m., Saturday</p> | <p>5690 kc. FIQA 50.1 meters ADMINISTRATION DES P. T. T. Tananarive, Madagascar Tues., Wed., Thurs., Fri., 9:30- 11:30 a. m. Sat. and Sun., 1-3 p. m.</p> | <p>4795 kc. W3XZ 62.56 meters WASHINGTON, D. C.</p> | <p>4105 kc. ★NAA 74.72 meters ARLINGTON, VA. Time signals, 9:57-10 p. m., 11:57 a. m. to noon</p> |
| <p>6040 kc. ★W4XB 49.67 meters LAWRENCE E. DUTTON care Isle of Dreams Broadcast Corp., Miami Beach, Fla.</p> | <p>6000 kc. ★RV59 B 50 meters RADIO MOSCOW, U. S. S. R. 2:00-5:00 p. m. daily</p> | <p>5550 kc. W8XJ 54.02 meters COLUMBUS, OHIO</p> | <p>4795 kc. VE9BY 62.56 meters LONDON, ONTARIO, CANADA</p> | <p>3620 kc. DOA 82.90 meters DOEBERITZ, GERMANY</p> |
| <p>6040 kc. W1XAL 49.67 meters BOSTON, MASS.</p> | <p>5970 kc. ★HVJ -B- 50.26 meters VATICAN CITY (ROME) 2-2:15 p. m., daily. Sun., 5-5:30 a. m.</p> | <p>5170 kc. PMY -C- 58.00 meters BANDOENG, JAVA</p> | <p>4770 kc. ZL2XX 62.80 meters WELLINGTON, NEW ZEALAND</p> | <p>3560 kc. OZ7RL 84.24 meters COPENHAGEN, DENMARK</p> |
| <p>6030 kc. VE9CA 49.75 meters CALGARY, ALTA., CANADA</p> | <p>5900 kc. HJ4ABE -B- 50.80 meters MEDELLIN, COLOMBIA Mon., 7-11 p. m.; Tues., Thurs., Sat., 6:15-8:00 p. m.; Wed. and Fri., 7:30-10:30 p. m.</p> | <p>5170 kc. PMB 58.00 meters SOURABAYA, JAVA</p> | <p>4760 kc. Radio LL 63.00 meters PARIS, FRANCE</p> | <p>3256 kc. W9XL 92.50 meters CHICAGO, ILL.</p> |
| <p>6023 kc. XEW 49.8 meters MEXICO CITY, MEXICO</p> | <p>5857 kc. XDA 51.22 meters MEXICO CITY, MEXICO</p> | <p>5714 kc. HCK -B- 52.5 meters QUITO, ECUADOR, S. A.</p> | <p>4750 kc. WOO 63.13 meters OCEAN GATE, N. J.</p> | <p>3156 kc. PK2AG 95.00 meters SAMARANG, JAVA</p> |
| <p>6020 kc. DJC -B- 49.83 meters ZEESEN, GERMANY 7:00-9:00 p. m., irregular</p> | <p>5835 kc. HJ1ABB -B- 51.40 meters BARRANQUILLA, COLOMBIA Daily, 8-10 p. m.; Thurs., 8-10:30 p. m.</p> | <p>5145 kc. OK1MPT -X- 58.31 meters PRAGUE, CZECHOSLOVAKIA</p> | <p>4700 kc. W1XAB 63.79 meters PORTLAND, ME.</p> | <p>3124 kc. WOO 96.03 meters DEAL, N. J.</p> |
| <p>6005 kc. VE9DR -B- 49.96 meters CANADIAN MARCONI CO. Drummondville, Quebec 7 a. m.-11 p. m., daily, exc. Sun.; 11 a. m.-10 p. m., Sun.</p> | <p>4975 kc. W2XV 60.30 meters RADIO ENGINEERING LAB- ORATORIES, Inc. Long Island City, N. Y.</p> | <p>4795 kc. W9XAM 62.56 meters ELGIN, ILL. (Time signals.)</p> | <p>4430 kc. DOA 67.65 meters DOEBERITZ, GERMANY 6-7 p. m., 2-3 p. m., Mon., Wed., Fri.</p> | <p>3076 kc. W9XL 97.53 meters CHICAGO, ILL.</p> |
| <p>6005 kc. VE9CU CALGARY, CANADA Irregular</p> | <p>5710 kc. VE9CL 52.50 meters WINNIPEG, CANADA</p> | <p>4273 kc. ★RV15 70.20 meters FAR EAST RADIO STATION Khabarovsk, Siberia Daily, 3-9 a. m.</p> | <p>4116 kc. WOO 72.87 meters DEAL, N. J.</p> | <p>2342 kc. W7XAW 128.09 meters FISHER'S BLEND, INC., Fourth Ave. and University St. Seattle, Washington</p> |
| <p>6005 kc. VE9CU CALGARY, CANADA Irregular</p> | <p>5710 kc. VE9CL 52.50 meters WINNIPEG, CANADA</p> | <p>4116 kc. WOO 72.87 meters DEAL, N. J.</p> | <p>1560 kc. W1XAU 199.35 meters BOSTON, MASS.</p> | |

A Word of Explanation About S. W. Schedules

This list is compiled from many sources, all of which are not in agreement. In fact, conflicting data are received sometimes from the stations themselves. We are constantly writing to stations all over the world and reading reports from hundreds of correspondents. We invite individual listeners to inform us of any stations not listed herewith, or operating on frequencies or hours different from those indicated. All times given are Eastern Standard.

Listeners living in zones operating on daylight saving time must make their own corrections.

Special note: please do not ask us to identify unknown stations from snatches of voice or music. This is utterly impossible. Make a notation of the dial setting and try for the station again until you get an understandable announcement. This list will appear again with last minute corrections, in the December issue.

When to Listen In

By M. Harvey Gernshack

Daylight Saving Time

Daylight time ends the last Sunday in September in the U. S. and Canada and slightly later in France and England. The English Empire stations' schedules will not be affected, as they are fixed on Greenwich Time all year round. Many U. S. and some foreign stations will make extensive changes in their schedules at the time of the change-over. Listeners should make note of this and be prepared for recording the changes.

The British Empire Stations

These stations are at present operating as follows:

Zone 1 (Australia, New Zealand) 12:15 2:15 a.m. on GSF (15, 140 kc.) and GSD (11,750 kc.)

Zone 2 (Indian Ocean) 8:30 a.m.-12:30 p.m. as follows: GSG (17,790 kc.) 8:30 a.m.-9:30 a.m. GSB (9,510 kc.) 11:30 a.m.-12:30 p.m. GSF (15,140 kc.) 9:30 a.m.-11:30 a.m. GSE (11,865 kc.) 9:30 a.m.-12:30 p.m.

Zones 3 and 4 (East and West Africa and South America) 1-5:30 p.m. on GSB (9,510 kc.) GSD (11,750 kc.)

According to "World Radio," the publication of the B. B. C. devoted to empire broadcasting, a new antenna array is now being used in connection with GSD trans-

missions to Zone 4 from 3-5:30 p.m. This antenna is directed so that it will cover South America and the West Indies, as well as West Africa.

From 1:00 to 3:00 p.m. both GSB and GSD are directive to East Africa and the eastern Mediterranean, and from 3:00 to 5:30 p.m., GSB is directed at West Africa, which GSD also embraces the West Indian and also South America area.

Zone 5, Canada, North America 6:00 to 8:00 p.m. GSB (9,510 kc.) GSF (15,140 kc.)

(GSF will probably have been abandoned in favor of GSD or GSA by mid-September.)

SHORT WAVE QUESTION BOX

BEST WIRE SIZE

Harrison J. Blind, W. Lafayette, Ind., asks,

(Q) What is the best wire size for short-wave plug-in coils wound on tube bases or similar forms?

(A) Several years ago this simple question would have aroused a storm of articles and arguments about "low losses." However, we now know from experience that the size of wire used on short-wave coils intended for regenerable receivers is not at all critical. For small forms like tube bases, anything between No. 20 and No. 26 D. C. C. wire is perfectly satisfactory for the grid windings; for ticklers and primaries wire as thin as No. 28 is all right.

For coils requiring only a few turns on larger forms, No. 18 or No. 14 enameled wire is recommended because it holds better against the form and will not work loose through handling as readily as thinner wire will.

Enamel insulation is all right only if the turns are spaced. For close-wound coils it makes the turn-to-turn capacity too high. Double cotton covering gives much greater spacing and brings this "dead" capacity down to a reasonable amount.

BLUEPRINTS

We wish to advise our readers that we have no blueprints or other prepared diagrams of any kind other than the diagrams and picture layouts that appear in the magazine. These diagrams are prepared at considerable expense, and are as clear as any radio drawings can be. The picture layouts particularly are self-explanatory and should enable any experimenter to build the sets illustrated. These diagrams have been followed successfully by people who never before built radio sets—a tribute that speaks for itself.

2 TUBE DIAGRAM

Russell Morgan, Charleston, W. Va. (Q) Will you please publish the circuit of Mr. Denton's "2-Tube A.C. All-Around Short-Wave Receiver" which appeared in the September issue of SHORT WAVE CRAFT in 1932?

(A) The diagram you request is shown on this page. Coils that will work with this set will be found on page 333.

SIZE OF R.F. CHOKES

James E. Anderson, Keyser, W. Va. (Q) What is the exact size of the R.F. chokes used in the "4,000 Mile Receiver" described in August, 1933 SHORT WAVE CRAFT?

(A) About the most satisfactory size

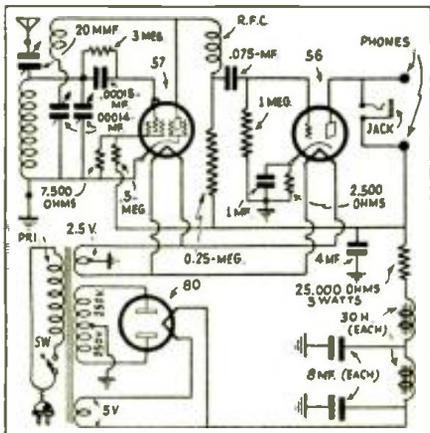

Circuit for Mr. Denton's 2-Tube A.C. All-Around S-W Receiver.

● Because of the amount of work involved in the drawing of diagrams and the compilation of data, we are forced to charge 25c each for letters that are answered directly through the mail. This fee includes only hand-drawn schematic drawings. We cannot furnish "picture-layouts" or "full-sized" working drawings. Letters not accompanied by 25c will be answered in turn on this page. The 25c remittance may be made in the form of stamps or coin.

Special problems involving considerable research will be quoted upon request. We cannot offer opinions as to the relative merits of commercial instruments.

Correspondents are requested to write or print their names and addresses clearly. Hundreds of letters remain unanswered because of incomplete or illegible addresses.

R.F. choke to use in an all band short-wave receiver is 5 millihenries.

(Q) Has the high voltage winding of the plate voltage a center tap and where is it connected?

(A) The high voltage winding has a center tap (which was not shown in the diagram). It is connected to the common ground indicated by the heavy line.

(Q) Where can I obtain the coil data for this receiver?

(A) On page 213 of the August issue you will find complete data for detector coils. The coils used in the detector of the "3-Tube Electrified Signal Gripper" will work O. K. with Mr. Dunsmore's set.

IDENTIFYING I.F. TRANSFORMERS

Albert J. Miller, Scranton, Pa., asks,

(Q) Several months ago you told how to tell the difference between the primary and the secondary of an audio transformer, according to their relative resistances. I have an assortment of intermediate-frequency transformers taken from some old super-heterodynes. How can I tell the two windings apart on these? The resistance method doesn't seem to work.

(A) While there is a very marked difference in resistance between the primary and secondary of an audio transformer, there is only a very slight difference in most I.F. transformers; in fact, the two windings are likely to be pretty nearly alike in this respect.

In many I.F. transformers only one tuning condenser is employed, and almost without exception this is connected across the secondary, with the fixed plate going to the grid lead. Once you have the secondary spotted, you can readily try reversing the primary leads for best results. If the transformer has two tuning condensers, you are pretty safe in using either winding as either primary or secondary.

RADIO INTERNATIONAL GUILD

Victor M. Zerbi, Trudeau, N. Y., asks, (Q) Will you please inform me as to whether the Radio International Guild still exists, and if so, what is its address?

(A) To the best of our knowledge the Radio International Guild has been out of existence about two years. Its headquarters were formerly at Lawrence, Mass., and previously in Brooklyn, N. Y.

MF. AND MMF.

H. Newman, Bronx, N. Y., asks, (Q) In your diagrams and lists of parts I see condensers listed as both "mf." and "mmf." I am confused by these abbreviations and wish you would explain them clearly.

(A) The abbreviation "mf." stands for "microfarad," which is one-millionth of a farad, the unit of electrical capacitance. The abbreviation "mmf." is a millionth of a millionth of a farad, and is used to designate the sizes of very small conden-

sers whose value in "mf." would require a lot of ciphers. For instance, a condenser of .00005 mf. capacity is easier to list if it is given as 50 mmf. The popular .00014-mf. variable condenser used for short-wave tuning may also be written as 140 mmf. For the sake of convenience in talking, the "mmf." may be expressed as "micromikes."

TUNING CONDENSER FOR "PERCOLATOR" RECEIVER

George Bixler, Milwaukee, Wisc. (Q) What size tuning condenser is used in the "Percolator" receiver on page 72 of the June, 1933 SHORT WAVE CRAFT?

(A) With the coil data given in the text a 75 mmf. condenser will be needed to cover the various bands.

(Q) Would a wire-wound potentiometer work better than a carbon one?

(A) If a one microfarad by-pass condenser is shunted across the potentiometer, there will be no difference in the operation of either the carbon or wire-wound type.

"SIGNAL GRIPPER" QUERY

Walter Strzalkowski, Dover, N. J. (Q) Can you tell me the value of the R.F. choke coil used in the "3-tube Signal Gripper" described in SHORT WAVE CRAFT, November, 1932?

(A) The value of the choke coils used in the various Doerle receivers is 5 millihenries.

(Q) Is a 100 mmf. condenser suitable for the R.F. and detector stages?

(A) A 100 mmf. condenser will work O. K. but with the coils described for this set there will be no over-lap in the tuning range and there may be a slight space not covered between the ranges of the coils.

BAND-SPREAD

Edward Frye, St. Albans, N. Y. (Q) Could you please tell me the value of the R.F. choke used in the "Electrified 3-Tube Doerle Signal Gripper"?

(A) This is a 5 millihenry choke.

(Q) Could I introduce "band spreading" in this circuit by simply paralleling the regular tuning condenser with one of a smaller value?

(A) Yes—the added condensers will then be used for tuning and the large ones for setting the bands. The capacity of the added condensers would be between 20 and 25 mmf.

S. W. ADAPTER

J. W. Fuller, Chattanooga, Tenn. (Q) Would you publish a diagram of the "Simple Short Wave Adapter" described in the May, 1933 SHORT WAVE CRAFT using a 227 instead of the battery type tube?

(A) Here is a circuit of the simple short wave adapter modified to use the type 27 tube with 2½ volts A.C. on the filament.

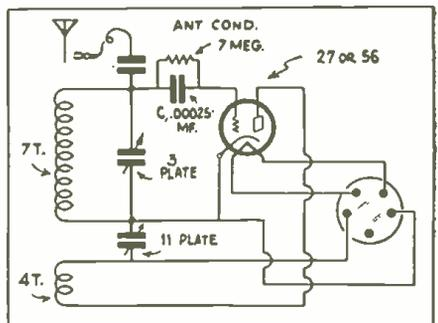

Hook-up for S-W Adapter, using a 27 tube instead of a battery type tube.

The "53" 1-Tube Twinplex

(Continued from page 332)

Detector Action Strong

The use of this tube as a detector results in a substantially greater output than is possible from the usual low- μ triode, while maintaining the desirable characteristics of this type of regenerative detector; namely stable and foolproof operation and simplified construction. As is well known, a screen-grid detector is often rather tricky in operation, especially when regeneration is controlled by screen-grid voltage variation, which often proves somewhat confusing to a beginner.

Regeneration is controlled by varying the plate voltage by means of a 25,000 ohm potentiometer. Independent volume control is provided by a 200,000 ohm potentiometer across the audio frequency transformer secondary as the volume often becomes too great for comfortable headphone reception particularly on strong amateur and 49 meter broadcasting stations.

The tuning condenser has a capacity of 140 mmf. and is employed in conjunction with a set of short wave octo coils.

Plate Supply from Batteries or "B" Eliminator

It will be noted that a plate potential of 180 volts is required and this may be obtained either from dry batteries or a well filtered "B" supply. The heaters require 2½ volts A.C. which may be obtained from a suitable step down transformer.

The general layout of the various parts can be noted from the photographs. It will be seen that an aluminum panel is employed in conjunction with a wood baseboard. The panel is 6"x9"x1/16" and the baseboard 7"x9"x¼". The variable condenser along with the two potentiometers are mounted on the front panel while the remaining apparatus is mounted to the baseboard. External connections are made by means of Fahnestock clips mounted at the rear of the baseboard.

The antenna compensating condenser is made by connecting a piece of bus-bar wire to the antenna clip and bending upright as shown. The other electrode consists of about 15 turns of hook-up wire coiled around the bus bar. Adjustment is effected by moving the coil off of the wire until the desired coupling is obtained. For this reason, it is desirable not to wind the hook-up wire too tightly around the bus-bar or it will not be possible to slide the coil conveniently. The adjustment of this condenser is not critical and for normal operation can be left "all in." When "dead spots" produced by antenna absorption are encountered the coil can be moved off the busbar until the dead area is reduced to one or two dial divisions. As this results in decreased input it is advisable to increase this capacity when the "dead spot" area has been passed.

When wiring the set it is absolutely essential to ground one of the heater lines, as shown, if satisfactory operation is to be obtained.

Operation and Results Obtained

In operation, the set is exactly the same as the conventional two tube regenerative receiver and consequently it will not be necessary to go into detail regarding same. The results obtained during a week of testing have been exceedingly good. The foreign stations received during this period include EAQ, GSB, GSA, DJC, HKD and OXY. No listening was done during the daytime which accounts for the absence of 25 meter stations. The receiver is also very satisfactory for C.W. reception.

Parts Required

- C₁—See text
- C₂—Hammarlund "Midline" midget variable condenser—140 mmf., Type MC-140-M.
- C₃—Molded mica condenser—.0001 mf.
- C₄, C₅—5-.5 mf. dual by-pass condenser.
- C₆—.0005 mf. Molded mica condenser.
- L₁, L₂—Set of short-wave Octo-Coils 16-200 meter.

THOROUGHbred

... the FB-7

THOROUGHbred horses usually win. So do thoroughbred receivers. There is a pedigree behind the NATIONAL FB-7. NATIONAL CO. has been making Engineering Specialties since 1914. In 1922, it pioneered a fully equipped Radio Laboratory and entered the Radio field. Since then the name of NATIONAL has been synonymous with fine radio. Five full years ago, short-wave listeners heard around the world with the first NATIONAL Short-Wave THRILL BOXES. Each year since then NATIONAL Short-wave Receivers have been developed and improved. . . . Pedigree counts. The FB-7 is a winner.



FB-7 Highspotted

The FB-7 has a 7-tube superheterodyne circuit, with an electron-coupled beat-frequency oscillator which helps materially in tuning in distant foreign stations. Exclusive features include: Front-of-panel coil-change without disturbing shielding; Full-vision velvet-vernier dial; Tuning-chart on front panel; Class A power-pentode output . . . Loudspeaker operation with fine quality; "True-tracking" single control tuning; Calibrated volume-control; All adjustments made from top without removal of chassis from cabinet; No frequency-drift. Complete specifications given in our catalogue.

NATIONAL FB-7 SHORT-WAVE RECEIVER



"Air-Dielectric" Tuned I. F.

Using the Type AT-500 NATIONAL Air Dielectric condenser tuned transformer with self-locking velvet vernier drives and improved litz-wound coils on Isolantite forms. Both peaking adjustments on top. Recommended in place of standard model with standard NATIONAL I. F. transformers, particularly for use in the Tropics and other locations with high humidity.

Power-Operated

The FB-7 operates on A.C. from the NATIONAL 5887 or 5880 Short-Wave Power Units, or if maximum undistorted output is desired, from the NATIONAL 5897 Power Unit. R. C. A. Licensed. Made also for 6 volt D.C. operation.

Send in Coupon Today!

NATIONAL CO., INC.
61 Sherman St., Malden, Mass.

Gentlemen: Please send me your latest 16-page catalogue. I enclose 6c in stamps to cover mailing cost.

Name

Address

SWC 10-33

Aligning S-W Coils

(Continued from page 347)

- RFC—Hammarlund isolantite R.F. choke, 8. millihenrys, Type CH-8.
- R₁—3 meg. grid-leak; Lynch (International).
- R₂—400 ohm wire-wound Resistor.
- R₃—200,000 ohm potentiometer (Acratest)
- R₄—25,000 ohm potentiometer (Acratest)
- R₅—50,000 ohm resistor, Lynch (International).
- T₁—Audio frequency transformer.
- 1—Alden 4 prong socket, type 481X.
- 1—Alden 7 prong socket, Type 487.
- 7—Fahnestock clips.
- 1—Type 53 Tube.
- 1—Roll hook-up wire.
- 1—National Type "B" Velvet-Vernier dial (0-100-0).
- 1—Aluminum panel 6"x9"x1/16".
- 1—Baseboard 9"x7"x¼".
- 1—Type 53 tube; Gold Seal, Arco, Van Dyke.

sult. Unwinding turns is not feasible as the coils do not ordinarily vary sufficiently to necessitate this, and it is difficult to remove just enough wire. To unwind half a turn or even less is not practical, because that would mean drilling new holes through which to lead the wires.

The problem is solved by moving the turns of wire on the coils, which serves the same purpose as bending the plates of the tuning condensers. The illustration shows how two turns of a coil are being slid away, so that the self-induction can be reduced by increasing the spacing between turns. The spaced turns can then be held in place by paraffin or sealing wax.



1 + 2 =
The Nozac*
 (no sack).
 You know when it's filled, when to refill it. Demand the quick, easy, positive mechanical Nozac filling action. See the Nozac before you buy... Compare... \$5 and more. Other Conklin \$2.75, \$3.50 and more. Pencils \$1.00 and more... Ask your dealer.

THE CONKLIN PEN COMPANY
 Toledo
 Chicago San Francisco
 *Proved by over 2 years of general public use.

Conklin
NOZAC
REG. U.S. PAT. OFF.
SATISFACTION GUARANTEED



STOPPANI BELGIAN COMPASS
 Worth \$60
 your price **\$4.50**
GOLD SHIELD PRODUCTS CO.
 112 Chambers St. S. W. E. New York, N. Y.

SEXOLOGY

THE MAGAZINE OF SEX SCIENCE

SEXOLOGY, foremost educational sex magazine, is written in simple language and can be read by every member of the family. It is instructive, enlightening—not a risqué book—contains no jargon. Devoted to Science of Health Hygiene.

(Contains 25 important articles on Sex Science, 68 pages, with attractive two-color cover. Here are a few of the more important articles: Pregnant men; Sex Starvation; Circumcision of Women; Men Who Suckle Infants; Church and Sexual Education; Menstruation in Monkeys; the Birth of Stone Babies; Sex Crimes; A Boy or a Girl? Sexual Selection; Control of Syphilis; Sexual Deficiencies; Impotency in Young Men; White Man Turns Negro, etc.)

Get a copy of SEXOLOGY on any newsstand, or if your dealer cannot supply you, send 25c in stamps for a copy of the current issue.

SEXOLOGY 23 West Broadway New York, N. Y.

A Pocket-Sized S-W Receiver

(Continued from page 329)

wire close wound in a single layer, beginning $\frac{1}{8}$ " from one end. The tickler coil, wound adjacent to the secondary, consists of approximately 18 turns of No. 34 D. S. C. copper wire, wound in the same direction as the secondary. This winding will have to be experimented with in order to obtain oscillation over the entire range of the secondary condenser by means of the throttle condenser. Be sure to make these adjustments with the box lid closed as the proximity of the metal affects the frequency range as well as the degree of regeneration and oscillation. The primary winding consists of a single turn of No. 28 D. C. C. copper wire, wound directly over the secondary, one end being connected to the aerial tip-jack, the other to the grounded side of the secondary. The tuner is fitted with bakelite and supports "T", the tube passing through holes in them, which are screwed to the bakelite block under the tuner. This block is screwed to the back of the set, supporting the assembly. The leads from the windings pass through holes in the upper end support "T" to a terminal block "U" screwed to the back of the box under the 30 tube.

[The editor appends a table below giving coil data for use with a 90 mmf. tuning condenser; this corresponds approximately with the capacity (maximum) of the book-type condenser described by the author. You can also use a 100 mmf. condenser without causing any great change in the wavelength response.]

Coil data (National Co.) for use with .00009 m. f. (60 m. m. f.) tuning condenser connected across grid coil.

| P. | S. | T. | Wave Length Range in Meters |
|--------------|--------------|-------------|-----------------------------|
| 38 T. No. 32 | 63 T. No. 28 | 5 T. No. 32 | 200-115 m |
| 22 T. No. 34 | 35 T. No. 24 | 4 T. No. 32 | 115-65 m |
| 13 T. No. 34 | 20 T. No. 18 | 4 T. No. 32 | 70-40 m |
| 8 T. No. 34 | 12 T. No. 18 | 3 T. No. 32 | 41-23 m |
| 4 T. No. 34 | 6½ T. No. 16 | 3 T. No. 32 | 25-14.5 m |
| 2 T. No. 34 | 3 T. No. 16 | 3 T. No. 32 | 15-9 m |

Dis. form 1½", 6 pin.
 T = tickler; S = secondary or grid coil; P = primary or antenna coil.

Tuning Condenser

The tuning condenser in this set is a hinged plate affair with mica dielectric. It is controlled by means of a toothed celluloid disc "E" similar to the one used on the throttle condenser and has a pinch wheel vernier drive to the cam shaft, which gives a turns ratio reduction of 5½ to 1. A cam shaft is fitted with a 1/16" bevelled edge brass wheel which engages with a much smaller split wheel, the halves of which pinch the brass wheel due to the pressure of a spring washer and cause it to rotate when the small wheel is turned by means of the celluloid disc. The cam on the same shaft with the large brass wheel is so fashioned as to give about a quarter inch of motion to the open or free end of the movable condenser plate, with one complete revolution of the cam. A spiral steel spring pulls the movable plate away from the side of the box, which serves as the stationary plate of the condenser, at an angle causing it to bear against the cam and to move in either direction with the rotation of the cam. The movable plate measures 2½" by 1½" and must be notched out 1½" by ¼" to clear the brass vernier wheel. The plate is hinged to the side of the box with ¼" brass hinges using 2-56 screws. However, the plate must be insulated from the box with bakelite strips in order not to short-circuit the condenser. Mica .0005" thick is cemented to the under side of the movable plate as a dielectric. The cam and vernier shafts have bearings in a "U"-

shaped frame which is screwed to the back side of the box, supporting the whole vernier assembly.

The rheostat for controlling filament voltage is a midget of 20 ohms resistance fitted with a 1/16" notched celluloid wheel 1½" in diameter. The disc does not project through the box but is gotten at through a notch in the side of box, as shown in the photos. With all the resistance in circuit, the tube will receive very close to two volts or correct filament voltage. This leaves all of the resistance to be cut out as the filament cells drop in voltage with use. The rheostat is mounted by means of an "L"-shaped bracket to the back side of the set box, as shown in the photo.

The filament battery consists of two 1½ volt unit flashlight cells connected in series by means of a system of clips, giving 3 volts maximum. The positive and negative clips, are of stiff spring brass or bronze screwed to a ¼" bakelite block 2" square. This block is supported from the back of the box by means of four ¼" brass pillars ½" high, leaving space for mounting the grid condenser and grid-leak, of which more anon. A series connecting plate, "O," is screwed to the bakelite block on the edge opposite from the spring clips. This plate has a dent in one corner for connecting to the negative of the left cell, but is left smooth for connecting to the positive cap on the right cell. Side retainers of thin aluminum are screwed to the bakelite block to keep the cells in line with the connection clips as shown in the photo.

Assembling the "B" Battery

Although most constructors would not care to fuss with the construction of a "B" battery, the one shown here is very easily constructed. It consists of 15 cells placed five in a row and three deep cemented together with "Tom Collins" celluloid cement. A good procedure is to cement five cells to a strip of writing paper and to each other. Make three groups of this sort and then cement them on top of each other, forming a rigid block. Then cover the block with a layer of writing paper and connect the cells in series by soldering a wire from the positive of one cell to the negative of the next, from cell to cell, running the leads down through the little spaces between the cells. In other words, the positive terminals all face one way and the negative the other. This scheme is used so that when the tops of the cells are treated with sealing wax to insulate them and protect the series connecting wires, there will not be wax projecting beyond both ends of the cells to unnecessarily use up valuable space in the box. The "B" battery is composed of seven ½" batteries, or 15 cells of the smallest sized fountain pen flashlight type, and will last six or eight months with the small amount of current drawn by the 30 tube.

The grid condenser is a .00025 mf. unit screwed to the under side of the "A" battery block, as already mentioned. The grid-leak is of 9 or 10 megohms resistance and consists of the resistance element from a glass tube enclosed type leak. It is connected across the terminals of the grid condenser and is held there by two tiny spring clips under the condenser terminal.

Dials may be made and cemented to the celluloid control discs, viewing them through holes in the lid.

The tuner may be wound for the 20 or 40 meter bands or even for the broadcast band, rather a part of it, as the condensers are not large enough to accommodate the whole band.

The circuit used is the well known regenerative one with throttle condenser control of regeneration and is shown in the accompanying diagram.

WORLD'S FINEST PHOTO-INSTRUMENT

*In all the
WORLD
No Other
CAMERA
Like This!*



The only Quick-Acting, Automatic Winding, Ground Glass Focusing Camera using Standard Roll Film. Good for all purposes. No Separate Parts or Attachments are Necessary!

**No Double Exposures with "PAL KO!"
It THINKS and COUNTS for you.**

Used by Government Educational Experts and leading Publications. Simple! Positive! Dependable!

3 Cameras in One! "PAL KO" takes full postcard 3A, or 2/3 or 1/3 this size—19 pictures on a 6 exposure film!

SAVINGS ON FILMS ALONE WILL SOON PAY FOR "PAL KO"

SATISFACTORY PERFORMANCE GUARANTEED OR MONEY REFUNDED!

SOLD DIRECT "FROM MANUFACTURER TO YOU."

WRITE TODAY FOR FREE CATALOG.

PAL KO Inc.

819 Wash. Blvd. CHICAGO Dept. S-C



**Infra Red
Health Lamp**

Table or Floor Model

Recommended by all health institutions and physicians *all over the world.*

Saves doctor bills!
Saves your health!
Saves your family a trip to the doctor or \$5.00 per trip.

Carbon Type Table Model

\$3.75

worth double the price.

Bulb Model—Write for special price.

Send for *instructive literature*

Gold Shield Products Co.

112 Chambers St., N.Y. City

speaker connected at the aft deck, a dance orchestra can be reproduced to its natural volume without any trace of distortion and with a degree of fidelity only possible with strictly custom design. The audio components of the power amplifier are all of high quality, the circuits carefully filtered and padded.

Power Pack

The power pack for this receiver consists of a full wave rectifier circuit using two type -81 tubes. The set speaker (1,000 ohms) is the main filter reactor, used in connection with an additional filter reactor. The filter condenser has a total of 18 microfarads, there being no noticeable A.C. hum in any of the speakers. The voltage divider is an extra large vitreous enameled type which, like all other parts, must be free from deterioration from salt air moisture. 450 volts D.C. are fed to the power amplifier tubes, well filtered and free from variations under full load.

Short-Wave Tuner

The short wave tuner is a super-heterodyne. The wavelength range of 15 to 200 meters is obtained using a switching arrangement in four bands. The first detector is a -24 tube, the oscillator a -27. The coupling between these two circuits is taken care of in the mechanical design of the antenna and oscillator coils both being wound on common forms for each band. The intermediate radio frequency amplifier has three high gain stages, tuned to 465 kilocycles. The intermediate radio frequency transformers are tuned on both the plate and grid sides, providing high selectivity. Selectivity being an important consideration on short waves, some quality of reproduction must be sacrificed at this point but not enough for the average listener to notice.

The output of the intermediate amplifier feeds into a second detector, -24, the plate circuit of which is resistance coupled. From this plate output, terminating in a jack, a patch cord is used to connect the output to the input of the broadcast receiver power amplifier for the reproduction of short wave programs over the loud speaker system.

The short wave tuner has its own power pack using a -80 full wave rectifier tube. No speaker being directly connected with this tuner, the power pack has a separate filter reactor in two sections together with filter condensers totaling 8 m.f.

The sensitivity obtained with this short wave tuner is very high and enough for all ordinary purposes.

Phonograph

The automatic electric phonograph is in a separate teakwood cabinet, the chassis being mounted on gimbals so that the mechanism stays level with the ship under way. This record changing mechanism takes ten records, 10-inch or 12-inch intermixed. Controls are provided enabling the rejection of any record, repetition, or even to turn a record over. The 33 1/2 r.p.m. or long playing records can be used as well as the standard type. Used with the main broadcast audio and power amplifier, the reproduction is second to none. The volume available is more than ordinarily required but of course it can be regulated to any desired level.

The receivers are mounted on teakwood panels which in turn are mounted on a teakwood frame (Fig. 4). By pulling the frame out on rollers, the entire assembly is available for inspection or adjustment. Connecting leads are flexible and long enough to permit operating the set while the frame is out of the cabinet.

In this cabinet space there are outlets for the field and voice lines from the

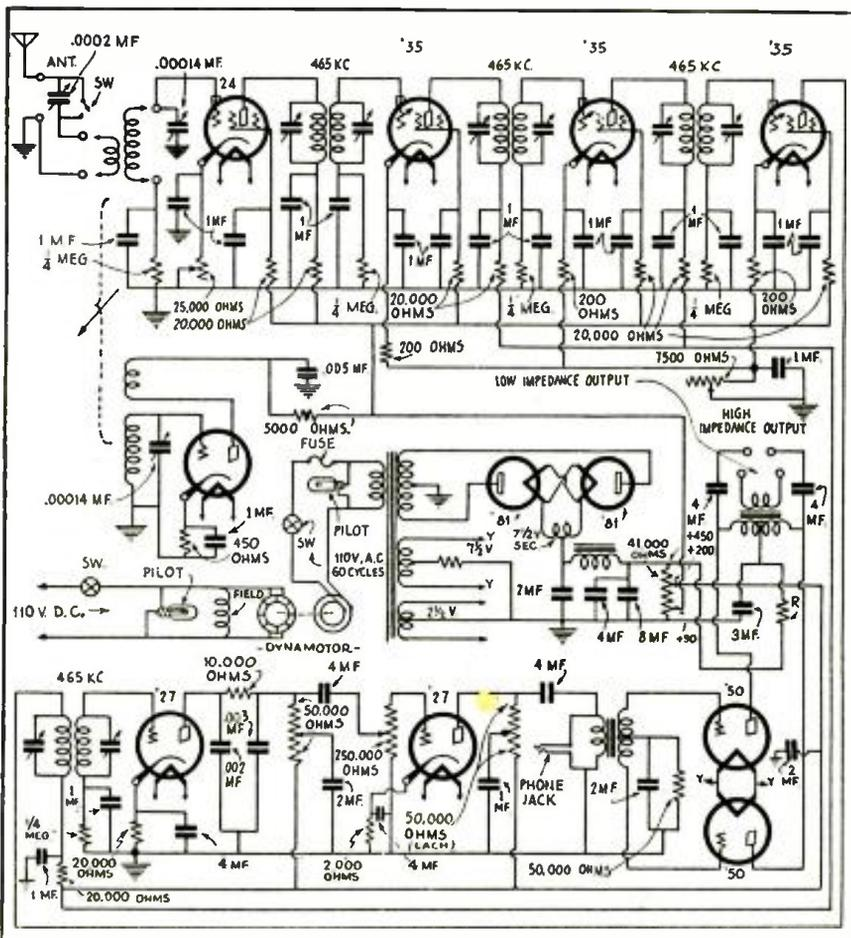

Wiring diagram for the "short-wave" superhet receiver installed on the yacht "Migrant."

different points for the portable speaker, also outlets to the rotary converter. On the front panels of the frame are the various auxiliary controls.

The antenna is run to a switch from which point it can be directed to either the main or auxiliary receiver. When directed to the main receiver it runs to a second antenna switch so that it can be connected either to the broadcast or short wave tuner. Switches are provided so that the portable speaker can be connected either to the main set or to the auxiliary set.

When the main switch is turned "on", it starts the rotary converter in the engine room which in turn feeds 110 volts 60 cycles A.C. to the gang of outlets. These outlets run to the main set, auxiliary set, short wave set and electric phonograph, each having an individual power switch. All these circuits are fused. The complete fundamental schematic wiring diagram is shown in Fig. 5.

Yacht "Migrant" Installation

The "MIGRANT" being a schooner, the problem is entirely different from that of any other type craft. On a schooner, the space is limited, everything must be compact and efficient. The fact that sails must be raised and lowered limits the antenna construction.

The top deck smoking room was the only place available for the main broadcast receiver, and as the room has a low height, the teakwood cabinet was correspondingly low. The cabinet must be fastened to the deck permanently to prevent shifting while under way. Allowing for this, the cabinet top is hinged, the front sections hinged and the lower compartments provided with removable doors, making everything accessible from the front. The entire rear of the cabinet is a copper wire screen on a frame but the bannister prevents this being removed unless the cabinet is moved.

The dynamic loud speakers for this set are permanently located at the Dining Room, Aft Deck, Radio Operator's Room, Officers' Mess and Crew's Quarters, besides the set speaker. These can be turned on and off from the set. The volume can be regulated at each speaker.

N. Y. Stations Heard at Panama

The main broadcast receiver is very similar to that on the "ARAS," two -50 power tubes push pull being used in the output stage. All six speakers can be driven to full volume without any trace of distortion. This receiver was designed primarily for quality reproduction and with reasonable range. In actual use, New York broadcast stations have been received in the afternoon while the yacht was lying in Gatun Lake, Panama Canal. Good daylight reception from New York was received during winter afternoons with the yacht at Miami.

The yacht has a large number of electrically driven appliances, such as pumps, generators, ventilators, steering engine, etc., some of which caused disturbances. Elimination tests were made to determine which motors caused the trouble and these were provided with filters or suppressors.

As the "MIGRANT" cruises on long trips, the short wave feature was most important. A powerful short wave superheterodyne was designed, constructed and installed in the Radio Operator's room so that the owner could have the operator tune same. The signals received on this short wave set are sent over a transmission line to the smoking cabin where they can be fed through the main set's power amplifier and to the six different speakers. The schematic wiring diagram is shown on page 360.

13.8 to 200 Meter S.-W. Range

This short wave receiver covers 13.8 to 200 meters with six sets of coils. Other coils are provided to tune wavelengths up to 1,000 meters so that the apparatus can

OCTOCOILS

A Standard for Short Wave Set Builders Since 1928
Now in Use in More Than 60 Foreign Countries

The New Price is now \$2.25 per set of four

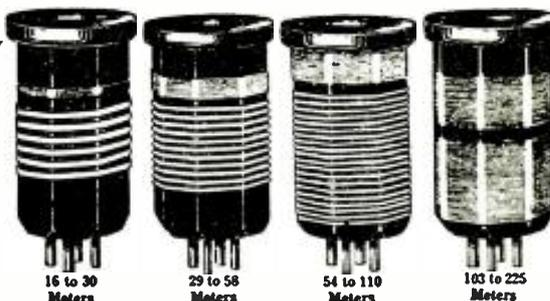

Wave-length Range 15 to 225 meters

Increased production has enabled us to tremendously reduce the price of OCTOCOILS always listing at \$5.00 per set. Wave length range 15 to 225 meters with .00015 variable condenser—wound on perfect dielectric bakelite forms in attractive colors—Ask the Hams—they know OCTOCOILS—At your dealer or all Kresge \$1.00 Stores—or sent pre-paid anywhere on receipt of price.

SHORTWAVE AND TELEVISION CORPORATION

Division of General Electronics Corporation, 70 Brookline Ave., Boston, Mass. Pioneer manufacturers of Television and short wave apparatus. Owners and operators of television and sound stations W1XAV, W1XAU, W1XG and W1XAL.

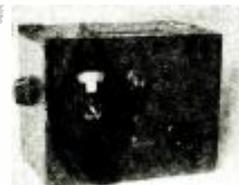

Size 4 x 4 1/2 x 6. Weight 3 lbs.

Minidyne

BRAND NEW CIRCUIT

No aerial! No ground! Easy to tune! Self contained with batteries and tube.

For 80 and 160 meterphone bands *Especially*. In actual test it picked up Police Calls over 100 miles. Convenient to carry under arm, in subway or auto.

Designed and built by one of the foremost engineering firms and pioneer short wave specialists. **\$7.95** Complete with a plain turning knob

WIRELESS EGERT ENGINEERING CORP.

175 Varick St., Dept. 8

New York City

International "Pro"

9-tube Short Wave Superheterodyne

With the International "Pro," Postal has reached the highest realm of the most advanced Short Wave Enthusiast. Tremendous sensitivity, high signal to noise ratio, true tracking, single dial control, band spreading and numerous other features—actually places the International "Pro" in a class by itself. The only 9 tube professional Short Wave receiver using a stage of R. F. ahead of the 1st detector that sells at this price.

CIRCUIT DESIGN

Entirely A.C. operated and humless, using 58 tuned R. F., 58 electron coupled oscillator, 57 1st detector, 2-58-465 K. C. I. F., 37 second detector, 58 audio beat oscillator, a 2A5-3 watt output and a 280 rectifier.

SECRET OF EFFICIENCY

The stability and sensitivity lies in the unique constructed coils (multiformers). Each band consists of an R. F. oscillator and first detector coils, individually compensated, shielded and accurately calibrated. By one half inch movement of the coil, contact is made for band spreading over 65% of dial. This circuit eliminates repeat spots, dead end losses and simplifies changing to different bands. Consistent foreign reception on this loud speaker a reality.

POSTAL RADIO CORP.

137 Liberty St., Dept. 5W, New York, N. Y. Cable Add. PostalRN



List Price \$175.00

The complete "Pro" kit with power supply and all necessary parts semi-assembled as illustrated \$41.50
 The above receiver completely wired, laboratory tested, calibrated and supplied with coil for any band 49.50
 9 matched Arceturus tubes 6.75
 Full range Rola dynamic speaker to match Beautiful black crystal finish sturdy metal cabinet with hinged top 5.50
 Drawer type coils for any band, sold separately 7.85
 Size in cabinet: 21" long, 10" high, 12" wide. Weight 38 pounds. 4.95

NEW

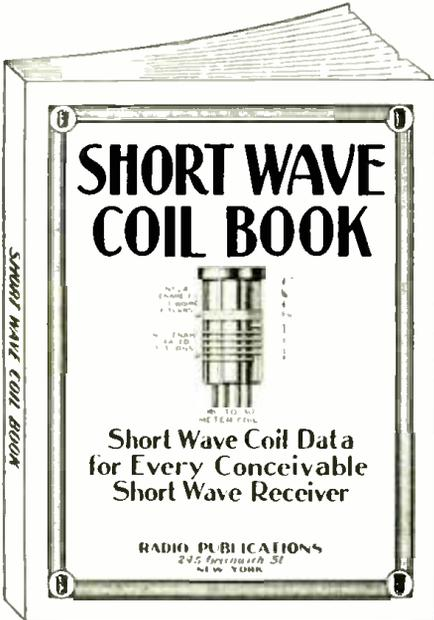

FOR the first time, it is now possible for the experimenter and short wave enthusiast to obtain the most exhaustive data on short wave coil winding information that has ever appeared in print.

As every experimenter who has ever tried to build a short wave set knows only too well by experience, the difference between a good and a poor receiver is usually found in the short wave coils. Very often you have to hunt through copies of magazines, books, etc., to find the information you require. The present data has been gotten up to obviate all these difficulties.

Between the two covers of this book you now find every possible bit of information on coil winding that has appeared in print during the past two years. Only the most modern "dope" has been published here.

No duplication. Illustrations galore, giving not only full instructions how to wind coils, but dimensions, sizes of wire, curves, how to plot them, by means of which any coil for any particular short wave set can be figured in advance, as to number of turns, size of wire, spacing, etc.

There has never been such data published in such easy accessible form as this.

Take advantage of the special offer we are making today, as due to increasing costs, there is no question that the price will increase soon.

RADIO PUBLICATIONS
245 Greenwich Street
NEW YORK, N. Y.

Radio Publications,
245 Greenwich Street,
New York, N. Y.

Please send immediately upon publication, your Short Wave Coil Book, for which I enclose 25c herewith (coin, U. S. stamps or money order acceptable). Book is to be sent prepaid to me.

Name.....

Address.....

City and State.....

also be used for regular broadcast band reception as an auxiliary.

Tubes are arranged as follows:

- 27 Oscillator
- 3 -35 Intermediate radio frequency stages at 465 K.C.
- 27 Second Detector
- 27 First Audio
- 2 -50 Power Push Pull tubes
- Power Pack (in separate case) has 2 -81 rectifiers

Two main controls cover the change of wavelength, one for the oscillator and the other for the antenna circuit. Auxiliary adjustments are provided, consisting of antenna series condenser, detector sensitivity, intermediate radio frequency amplifier sensitivity, and audio frequency amplifier input.

When the entire receiver is used, the output goes to a dynamic speaker in the *Radio Operator's* room. In cases where the output is directed to the main set's power amplifier over the transmission line, the dynamic speaker is disconnected in the voice coil circuit. The field of this speaker is used as the filter reactor of the power pack. Provision is made to use head phones and also a magnetic speaker as a monitor if desired.

The main set has its rotary converter in the engine room. The rotary converter for the short wave set is separate and is located in a valet's press room right next to the radio room. The converter for short wave work must be thoroughly filtered and of excellent design or it will cause trouble on some of the shorter wavelengths due to electrical disturbances.

This short wave set has high sensitivity and a very low noise level. Excellent results have been obtained including good reception from American short wave broadcast stations while the "MIGRANT" was in the Mediterranean.

9-Tube Superheterodyne Has Coil Switch

(Continued from page 349)

The main circuit of the 9-tube super consists of a 58 tuned R.F. stage, a 57 high sensitivity first detector, a 58 electron-coupled oscillator, a 58 first I.F. amplifier, a 58 second I.F. amplifier, 57 second detector, 58 electron-coupled audio "beat" oscillator for "CW" reception, a 2A5 output power tube in the A.F. stage, delivering three watts of undistorted audio signal energy; the rectifier tube being a type 280.

The I.F. amplifier stages are tuned to 465 kilocycles, with dual tuned I.F. transformers, which are wound with Litz wire, a voltage gain of approximately 100 times being thus obtained.

This "pro" type receiver while especially designed for commercial and amateur short-wave communication purposes, is simultaneously an excellent short-wave receiver for the general short-wave "fan" who is interested in hearing the "foreign" DX stations, due to the high sensitivity and selectivity of the set.

List of Parts—Postal Superhet

- 4—Postal Multiformers
- 1—Special Postal socket, for Multiformer
- 1—3 gang 140 mmf. Postal condenser
- 1—40 mmf. Ant. comp. condenser
- 3—465 K.C. I.F. transformers
- 1—Audio beat oscillator coil 456 K.C.
- 1—Power transformer, to handle 9 tubes
- 1—12 mf. condenser 450 volt working v.
- 1—8 mf. condenser 450 v. working v.
- 1—12,000 ohm. volume control and switch
- 1—75,000 ohm tone control
- 1—Single circuit jack, with single pole double throw switch
- 1—Toggle switch for "B" supply
- 1—Rotor switch for audio "beat" oscillator
- 1—dial and front plate
- 5—58 sockets
- 2—57 sockets
- 1—2A5 sockets
- 1—280 sockets
- 1—Speaker 5 prong socket
- 5—8 millhenry R.F. chokes

In designing special receivers which are guaranteed to give definite results and uninterrupted service, cost cannot of course be a first consideration. However, there are limits as to a reasonable cost for such special equipment.

Protection Against Salt Air

Salt air moisture ruins an ordinary set in a short period. Steel must be excluded unless essential. These special chassis are either heavy copper or aluminum, free from riveted joints which could corrode. As there is considerable vibration, all electrical joints are made mechanically first and then soldered. Alcohol and rosin soldering flux prevents these joints from corroding. Other mechanical joints are all made with lock washers. Where ordinarily a ½ or 1 watt resistor would be sufficient, a 5 watt resistor is used. Filter and by-pass condensers only taking 180 volts are designed to stand 800 volts continuously. The power transformers can stand a fifty per cent overload for 4 hours. The rotary converters can run continuously as they are only loaded to 65% capacity. All through the design this liberal degree of safety and security is carried out. All new tubes are inserted every four months and consequently the apparatus runs continually and satisfactorily and is expected to do so almost indefinitely.

The above described apparatus is not crowded, more than sufficient space being allowed originally for the components used. With this foresight it is now possible to modernize the receivers, substituting -58's in place of the -24's and -56's in place of the -27's with the extra parts required for still further improvements. It is contemplated that this will be done in the near future as the design enables it being accomplished quickly and economically.

- 1—Ant. Gnd. binding post.
- 8—.1 mf. tubular condensers
- 1—.05 mf. tubular condenser
- 1—.01 mf. tubular condenser
- 4—.001 mica fixed condensers
- 3—.0001 mica fixed condensers
- 1—.0000006 mmfd. condenser
- 1—25 watt wire-wound resistor 27,440 ohm; tapped 10,000 ohm, 10,000 ohm, and 7,440 ohm.
- 1—10 watt wire-wound resistor 1,000 ohm
- 2—60,000 ohm, 113 watt, pigtail resistors
- 1—15,000 ohm, 1 watt pigtail resistor
- 1—60,000 ohm, 1 watt pigtail resistor
- 3—25,000 ohm, 1 watt pigtail resistors
- 2—250,000 ohm, 1 watt pigtail resistors
- 1—350 ohm, 1 watt pigtail resistor
- 1—200 ohm, 1 watt pigtail resistor
- 1—100,000 ohm, 1 watt pigtail resistor
- 1—Cord and plug
- 1—Chassis 11"x19"x3"
- 1—Steel front panel 9¼"x20½"
- 6—Knobs.

A Novel S-W Converter

(Continued from page 337)

- | | | |
|-------------|----------|-------------------|
| FYA | 25.16 m. | Rocky Point |
| W8XK | 25. | WSBN |
| GSE | | GFVV |
| 12R0 | | GLSQ |
| WIXAL | | Amateurs all over |
| XDA | | Canada & U. S. |
| GSD | | |
| VE9 JR | | Code |
| FXA | 25.6 m. | LSX |
| LSX | | HAT |
| EAQ | | HAS |
| VK2ME | | SUR |
| GSC | | PLF |
| W3XAU | | TIR |
| | | DIM |
| HRP | | DHA |
| WIXAZ | | PPX |
| DJA | | UOR |
| W2XAF | | GOS |
| GSP | | etc. |
| VK3ME | | etc. |
| Rabat. Mov. | | (Am not of course |
| HKC | | including the "W" |
| HKA | | stations) |

Direction Finding for Amateurs

(Continued from page 347)

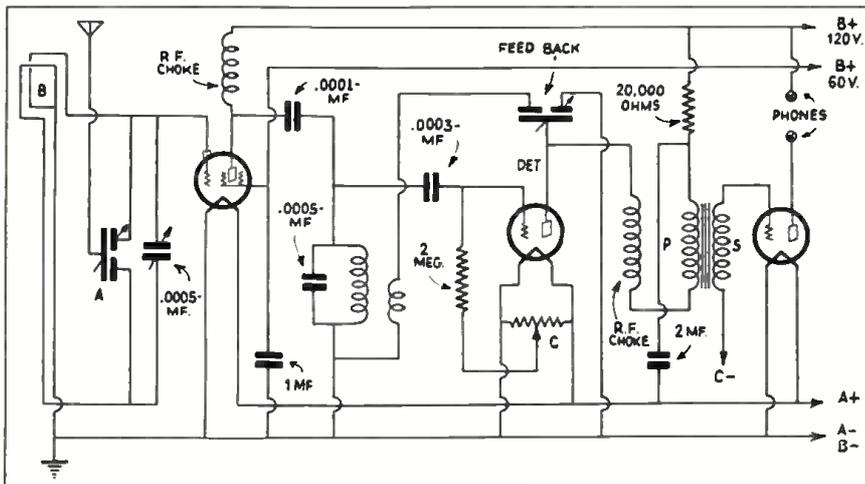

A 3-tube loop receiver for "direction finding," comprising a shield grid stage followed by a regenerative detector and a transformer coupled A.F. output stage.

found, until at a certain setting it will be found that signals disappear at a sharply defined position of the frame.

In the case of the three-valve (tube) set a similar frame aerial may be used; one consisting of ten turns on 12 inch sides, with 3/8 inch spacing is quite satisfactory. As a screen-grid valve (tube) will be used, it is essential to have fairly good screening (shielding), and again it is desirable to mount the entire set inside a metal box. The tuning arrangement following the S.G. valve (tube) may be conventional, and consists of either tuned anode (tuned plate) or tuned grid, with reaction (regeneration) winding. The number of turns depends, of course, on the type of coil; usually about two-thirds the

number of turns required for broadcast reception. Alternatively a special coil may be made on a 2 1/2 inch former, consisting of 35 turns with 9 turns for reaction (regeneration).

Those who do not mind the extra constructional work involved would do well to try adding the aerial and the earth (ground) shown in the diagram connected to the small single plate differential condenser, A, for neutralizing the effects of the vertical component, which tends, unless balanced out, to flatten the minimum volume positions. For the 160 meter band, the aerial need only consist of a vertical metal rod about 3 feet long, and the condenser should consist of a single moving plate and two separate fixed ones, each with an area of about 1 inch square.

Simple Switching for 2 Wave Ranges

(Continued from page 346)

switching not only the tuned circuits but also the regeneration coil or tickler of the detector circuit as well.

It is in the interest of simplicity and safety of operation to reduce the num-

ber of switches as much as possible. For this reason a back coupling coil (regeneration coil) common for both wave ranges is ordinarily used. But there is no doubt but that, by separate

\$20.00 Prize Monthly For Best Set

● THE editors offer a \$20.00 monthly prize for the best short-wave receiver submitted.

If your set does not receive the monthly prize you still have a chance to win cash money, as the editors will be glad to pay space rates for any articles accepted and published in SHORT WAVE CRAFT.

You had better write the "S-W Contest Editor," giving him a short description of the set and a diagram, BEFORE SHIPPING THE ACTUAL SET, as it will save time and expense all around. A \$20.00 prize will be paid each month for an article describing the best short-wave receiver, converter, or adapter. Sets should not have more than five tubes and those adapted to the wants of the average beginner are much in demand.

Sets must be sent PREPAID and should be CAREFULLY PACKED in a WOODEN box!

The closing date for each contest is sixty days preceding date of issue (October 1 for the December issue, etc.)

The judges will be the editors of SHORT WAVE CRAFT, and George Shuart and Clifford E. Denton, who will also serve on the examining board. Their findings will be final.

Articles with complete coil, resistor and condenser values, together with diagram, must accompany each entry. All sets will be returned prepaid after publication.

REQUIREMENTS: Good workmanship always commands prize-winning attention on the part of the judges; neat wiring is practically imperative. Other important features the judges will note are: **COMPACTNESS, NEW CIRCUIT FEATURES, and PORTABILITY.** The sets may be A.C. or battery-operated. Straight Short-Wave Receivers, Short-Wave Converters, or Short-Wave Adapters. No manufactured sets will be considered; **EVERY SET MUST BE BUILT BY THE ENTRANT.** Tubes, batteries, etc., may be submitted with the set if desired, but this is not essential. **NO THEORETICAL DESIGNS WILL BE CONSIDERED!** The set must be actually built and in working order. Employees and their families of SHORT WAVE CRAFT are excluded. Address letters and packages to the SHORT WAVE CONTEST EDITOR, care of SHORT WAVE CRAFT Magazine, 96-98 Park Place, New York, N. Y.

IMPROVE Your Radio with HAMMARLUND PARTS

EXPERIENCED builders don't have to be told that radio efficiency can be only as good as the parts used.

That is why Hammarlund parts have been first choice of experts since the beginning of broadcasting. They perform better and cost less in the long run.

Mail coupon for General Catalog.

S-W CONDENSERS

Special designs for receiving, transmitting, band-spread tuning, balancing. All types for short-wave, ultra short-wave and broadcast work. Built with watch-like precision.



COIL FORMS - SOCKETS



Sockets have Isolantite base and perfect spring contacts, for 4, 5 and 6 prongs. Isolantite Coil Forms for Short and Ultra Short Waves. No drilling. 4, 5 and 6 prongs.



SPECIAL

New 10-meter coils, for use in the famous COMET "PRO" and other short-wave receivers, now ready—\$5.00 a pair.

R-F CHOKES

Compact. Low loss. All types for short-wave, ultra short-wave and broadcast receivers and transmitters.

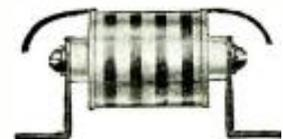

HAMMARLUND MANUFACTURING CO., 424-438 W. 33rd Street, New York, N. Y.

.....Check here for folder on COMET "PRO" Short-Wave Superheterodyne.

.....Check here for General Catalog "33."

Name

Address

SW-10

FREE 116 Page RADIO and SHORT WAVE TREATISE



Avail yourself now of the opportunity to receive the free 1933 summer edition of our Radio and Short Wave Treatise, No. 26. 116 solid pages of useful information, radio items, diagrams, illustrations, etc. Considerably larger and more instructive than our No. 25 issue. If you had our treatise No. 25 and incidentally all our previous issues, you are familiar with the type of book we publish; but the new No. 26—what a book! The entire editorial section is new from beginning to end—not a word remains. Considerable space has been devoted to articles for the radio beginner. This alone is worth its weight in gold. The Superheterodyne principle is thoroughly explained in this issue in clear, simple language. No. 26 is not just another catalog. It contains more valuable and up-to-date information than can be found in any radio text book on the subject.

Over 100 New Hook-Ups, Etc., 1000 Illustrations.

Over 100 New Hook-Ups, Etc., 1000 Illustrations. Incidentally all our previous issues, you are familiar with the type of book we publish; but the new No. 26—what a book! The entire editorial section is new from beginning to end—not a word remains. Considerable space has been devoted to articles for the radio beginner. This alone is worth its weight in gold. The Superheterodyne principle is thoroughly explained in this issue in clear, simple language. No. 26 is not just another catalog. It contains more valuable and up-to-date information than can be found in any radio text book on the subject.

PARTIAL LIST OF CONTENTS

Fundamental Principles of Radio—Ohm's Law—Discussion of New Tubes—Constructing a Triple Twin Amplifier—Constructing a Tiny A.C.-D.C. Portable Receiver—All About Superheterodynes—Eliminating Man-made Static—Constructing a Two-tube Short Wave "Globetrotter" Receiver—Completely revised and up-to-date Radio Tube Chart—\$3.00 Prize Suggestions—Radio Kinks, Etc., Etc.

WRITE TODAY. Enclose 4 cents for postage. Treatise sent by return mail.

RADIO TRADING CO.

100A Park Place New York City

1933 SHORT WAVE MANUAL BY DON.C. WALLACE

Winner of The Hoover Cup

ONE DOLLAR

Tells you hundreds of things you never knew before about short-waves.

This Manual with more than 156 pages of short-wave data shows you how to build models of the internationally famous Wallace sets. This famous Wallace Cup Set Winner costs approximately twenty dollars to build.

Here is something entirely new in short-waves. A complete receiving and transmitting system that uses no grounds. The Wallace System is the accepted method for greatest long-distance reception with least interference. It is the winner of the Hoover Cup for best short-wave communication.

What a surprise you will get when you receive your Manual. Acclaimed everywhere as the new authority on the subject. Only \$1.00 per copy, postpaid, in U. S.

Over 156 Pages—Over 200 Illustrations—Size 6x9 Inches—Flexible Covers—Attractive Colored Front Cover.

Mail This Coupon Today!

RADIO PUBLICATIONS
245-S Greenwich St.,
New York, N. Y.

Here is \$1.00. Rush a copy of the Wallace Short Wave Manual to

Name

Address

City..... State.....

back coupling coils which can be made for the given wave range, more can be accomplished and more even control will result.

Following is shown a solution in which, in spite of the separate back coupling coils (regeneration coils) a switch for the long wave feed-back coil is superfluous. The switching diagram for the Weagant regenerative scheme, for instance, is shown in the diagram at A. At B, the constructional details of the coils are shown.

Behold the Minidyne!

(Continued from page 339)

signal, but it also operates as the low frequency interrupter.

It may be of interest to point out that the sensitivity of the receiver is to a great extent dependent upon the frequency of the low frequency interrupter. The lower the frequency of the interrupter the greater the sensitivity of the receiver. It can be seen that when the frequency of the interrupter is lower, it allows the higher frequency oscillator more time to feed back upon itself and therefore amplify itself. However there is an optimum here which exists when the frequency of the interrupter becomes so low that the high frequency amplifier enters a state of oscillation, due to too much gain.

Two Main Controls

There are two main controls employed. One is a variable condenser which regulates the resonance frequency of the high frequency circuit; the other is a variable resistance which regulates the frequency of the low frequency relaxation circuit. Aside from these two controls there are the frequency change-over switch, filament and plate switch and jacks for the earphones.

In conclusion it may be of interest to the reader to point out that this receiver is ideal for remote control work, by utilizing a sensitive relay in the output circuit. The receiver can be energized by means of a small oscillator. Also due to its minuteness, it can readily be employed for operating models, etc.

Coil Data and Parts List for "Minidyne"

The loop and aeriels used on the "Minidyne" are wound in slots extending around the cabinet. The mean size of these slots are 4 1/4 by 5 1/4 inches, the slots being about 1/8 inch deep and 1/8 inch wide. For the 80 meter band, the grid coil consists of 5 turns of No. 32, double silk covered (D.S.C.) magnet wire; the tickler coil consists of four turns of the same sized wire, wound in the same slot.

In the model shown, the coils were not wound in even layers, but they may be if the builder so desires.

For covering the 160 meter band, the grid coil is made up of 10 turns of No. 28 D.S.C. wire (or No. 10-30 Litz wire may be used.) The tickler coil comprises 5 turns of No. 32 D.S.C. magnet wire.

The experimenter can easily wind other loop coils for this set to cover any desired bands, by simply using a smaller or greater number of turns of wire on the loop.

List of Parts—Minidyne

- 2 Loop coils as specified.
- 1 Wooden cabinet
- 1 Earphone, preferably new miniature 2,000 ohm earphone (or pair of light weight phones) No. 118. Name and address of manufacturer furnished on receipt of stamped, addressed envelope.
- 1 Set of 2 pin jacks
- 1 200,000 ohm potentiometer, Acra-test
- 1 1.5 megohm grid leak, Lynch, (International)
- 1 .00025 mf. condenser
- 2 .006 mf. condensers
- 1 .01 mf. condenser
- 1 50 mmf. variable condenser, Hammarlund, (National)
- 1 2-gang single-pole, double-throw switch, Eby
- 1 4 prong tube socket, Eby, (Na-Ald, Hammarlund, National)
- 1 30 type tube; Gold-Seal, (Arco, Van Dyke)
- 1 22 1/2 volt small "B" battery unit
- 2 1 1/2 volt flash light cells for "A" battery

DATAPRINTS

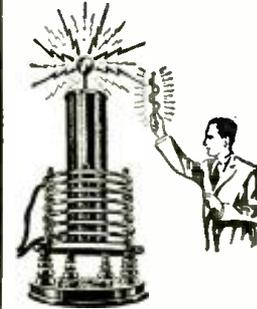

Just the Technical Information You Need To Build Electrical Apparatus

Dataprint containing data for constructing this 3 ft. spark Oudin-Tesla coil. Requires 1 K. W. 20,000 volt transformer as "exciter"; see list below.

..... \$7.95
Includes condenser data.

OTHER "DATAPRINTS" TESLA OR OUDIN COILS

- 36 inch spark, data for building, including condenser data\$0.78
- 8 inch spark, data for building, including condenser data; requires 1/4 K. W. 15,000 volt transformer; see list below 0.75
- Violetta type, high frequency coil data; 110 volt A.C. or D.C. type; 1" spark; used for "violet ray" treatments and "Experiments". 0.50
- How to operate Oudin coil from a vacuum tube oscillator 0.50
- 3 inch spark Tesla coil; operates on Ford ignition 0.50
- 3 inch spark Oudin coil; 110 volt A. C. "Klek-Coil" 0.50

TRANSFORMER DATA

- Any size, 200 to 5000 watts. (1 Primary and 1 secondary voltage data supplied—specify watts and voltage desired) \$0.60
- 1 k.w. 20,000-volt transformer data, 110-volt, 60-cycle primary. Suitable for operating 3 ft. Oudin coil 0.50
- 1/4 k.w. 15,000-volt transformer data, 110-volt, 60-cycle primary. Suitable for operating 8-inch Oudin coil 0.50
- Electric Welding Transformer (State secondary voltage) 0.50
- Induction Coils—1 to 12 inch spark data..... 0.50

MAGNET COIL DATA

- Powerful battery electro-magnet; lifts 40 lbs.....\$0.50
- 110 Volt D.C. magnet to lift 25 lbs. 0.50
- 110 Volt D.C., 300 lb. Lift, electromagnet 0.50
- 110 Volt D.C. solenoid; lifts 2 lb. through 1 inch 0.50
- 110 Volt D.C. solenoid, lifts 6 lb. through 1 inch 0.50
- 12 Volt D.C. solenoid, lifts 2 lb. through 1 inch 0.50
- A. C. Solenoid, powerful, 110-volt, 60-cycle 0.50
- MOTOR—1/16 H.P., 110 volt A.C. 60 cycle (suitable for driving 12" fan or light apparatus), constructional data 0.50
- 1200 cycle Synchronous motor 0.50
- 60 cycle Synchronous motor 0.50

TELEGRAPHONE—Records Voice or "Code" signals on steel wire by magnetism. Code can be recorded "fast" and translated "slow". Construction data (special)\$0.50

CLOCKS—Electric chime ringer. How to make one to fit on any ordinary clock..... 0.50

MISCELLANEOUS DATAPRINTS—

- Electric Ice Skates—How to make..... 0.50
- How to Thaw Pipes by Electricity (including 2 K. W. 110 vt. to 18 vt. transformer data)..... 0.50
- 20 motor circuits—hook-ups..... 0.35
- 20 practical telephone hook-ups..... 0.35
- Treasure Locator 0.50
- 100 mechanical movements for inventors 0.50
- Polarized Relay—Ultra Sensitive 0.50
- Electro-medical coil (shocking coil) 0.50
- Water-Wheels—How to build, and Light your house 0.50
- Model Ship plans 0.50
- Public Address System..... 0.50

20 "Electrical Tricks" for LODGES and PARTIES\$0.50

How To Fry Eggs on Cake of Ice Electrically... 0.50
"Rewinding" Small Motor Armatures..... 0.50

Other DATAPRINTS on—Centrifugal Pump for Small Fountains, etc; Model Electric Train—will carry child; Compressed Air power plant for model planes; etc. Write for prices.

(20% Discount on all orders for \$3.00 or more. No. C.O.D.)

The DATAPRINT COMPANY
Lock Box 322 RAMSEY, N. J.

The Evolution of Ultra Short Waves

(Continued from page 345)

Mesny was used. Here the tube inter-electrode capacities are effectively in series as regards the tuned circuit, and a high degree of electrical symmetry, which is very desirable, is attained. But the latter objection urged against the Hartley circuit still exists. Also, on account of the fact that only half of the tuned circuit is effective as a load in the plate of each tube, the effective anode load decreases much more rapidly with a decrease of wavelength than in the case of the single-tube circuit, though this is partly offset by the smaller effective inter-electrode capacities. The Mesny type of circuit is usually successful down to about 3 metres with ordinary tubes. Note that the effective reaction coupling in this case is partly electromagnetic. If the coils are constructed the wrong way round (uncrossed), the two reaction effects (electromagnetic, *via* the coils, and electrostatic, *via* the tube inter-electrode capacities) may cancel out and no oscillations be obtained.

A suitable single-tube circuit, apart from avoiding the necessity of pairs of matched tubes, can, if properly designed, be made to operate at shorter wavelengths than the Mesny type of circuit. The forerunner of the most successful type of single-tube circuit for this purpose seems to have been devised by Messrs. Gutton and Touly round about the year 1919, and is shown in Fig. 6. One comment upon it is necessary: the mistake was made of having the grid condenser in the position shown, where it is (to use an illuminating expression that the writer once heard) "knocked about at a high-frequency potential above earth." A later version of the circuit is shown in Fig. 7. When we examine it closely we find that it is hard to describe it in terms of conventional tube circuits. The beauty of this arrangement lies in the fact that the external inductances L1, L2 are continuous with the internal leads l1, l2 (Fig. 7 (a)), the whole tuned circuit being formed by the two inductances L1-l1, L2-l2 and the two capacities C and Cga, forming a "link." If carefully arranged, this circuit is much less likely to show the undesirable coupled circuits effect of the Hartley circuit previously described. Furthermore, there is no limit to the shortness of the external leads (L1, L2) beyond that of the length necessary for mechanical reasons, to connect C. Moreover, the grid and anode current leads can be led in (as shown *via* chokes) at points of low or zero H.F. potential with regard to earth.

Practically, the circuit values for Fig. 7 may be: V = any receiving power or super-power tube, Ra about 2,000-4,000 ohms; L1 and L2, pieces of stout copper wire, bent into semicircles, each piece about 4 in. long; C, any good make of air-dielectric miniature variable condenser, about 0.0001 mf., max.; and R, 10,000-20,000 ohms.

The grid and anode chokes may each consist of about fifty turns of fine wire on a former 3/8 in. diam. Filament chokes will usually be found necessary and may consist of the same number of turns (fifty) of stouter wire (say, 30 B.&S., for a tube taking not more than 0.25 amp. filament current) wound in bifilar (non-inductive) fashion on a former about 3/8 in. diam.

With the arrangement described, the wavelength obtained will be somewhere in the neighborhood of 2 1/4 metres. This circuit has the great advantage that it never refuses to oscillate, provided that the tube is O.K. By "decapping" the tube, cutting the external leads as short as possible, carefully adjusting the value of R (the grid leak), using a selected tube, and applying as much plate voltage as it will stand safely, the generated wavelength (with C at its minimum value consistent with os-

cillation) may be brought down to the neighborhood of 1 1/2 metres.

A close inspection of Fig. 7 (a) will show that if the self-capacities between the various parts are considerable (especially in the cases of the leads as shown by C1, C2) and the wavelength short, this circuit approaches the condition of a "tuned plate-tuned grid" circuit, with C as a coupling capacity. This means that in some circumstances the coupled circuit effect previously discussed may appear, but it is not usually troublesome. The only real snag is that, as the value of the tuning condenser C is decreased, there comes a point where the oscillations cease, owing to the fact that this condenser is also acting as a coupling between the grid and anode circuits, and decreasing its value in order to reduce the wavelength also reduces the coupling. The grid-current meter M (suitable value 0-2 ma.) provides a good indication of output, and is very useful for wavelength-measuring purposes in connection with absorption circuits and Lecher wire systems.

When it is desired to generate waves shorter than 1 metre, use must be made, as before mentioned, of an entirely different principle of operation. Strangely enough, and as a matter of interest, the circuit used is mechanically almost identical with the Gutton-Touly type of reaction circuit just described. In fact, the same circuit and tube may (provided conditions are suitable) be used without any (mechanical) change for the production of both types of oscillation. The general arrangement used is shown in Fig. 8. The point to notice is that the positive H.T. potential is applied to the grid, and a negative potential of lesser value is applied to the plate, which is rather an unconventional arrangement.

The dance of the electrons

The actual way in which this arrangement functions does not seem to have been definitely settled so far, but a plausible explanation which fits the experimental facts is as follows:—

On switching on the circuit, a cloud of electrons starts from the cathode and is attracted strongly towards the grid by the powerful positive potential thereon. Some of them are caught by the grid during their first flight, and take no part in the oscillatory action. Many, however, attain a high velocity and pass through the spaces between the grid wires, travelling towards the plate, where they are repelled by the negative potential thereon. If this latter potential is of the right value, the majority of the electrons just manage to reach within a short distance of its surface before their velocity is reduced to zero, when the positive charge on the grid again affects them and they are finally drawn back to it and absorbed. If the constants of the circuit connected to the electrodes are suitable, this rush of electrons (= a rush of current; in fact, a "transient") impels the circuit, the return swing of which assists the retarding voltage upon the plate to return the electron cloud towards the grid. During this impulse the second return swing (again in the positive direction with respect to the cathode) helps the positive potential upon the grid to attract a further batch of electrons from the cathode, and may also reattract many of those which had been repelled from the plate back towards it.

The net result is that the clouds of electrons may "dance" in time with the oscillations in the external circuit either between cathode and plate (Fig. 9 (a)) or between grid and plate (Fig. 9 (b)). In either case the frequency and therefore the wavelength is dependent upon the time of swing of the electrons between the two electrodes in

(Continued on page 368)

FREE



1933 Official Auto-Radio Service Manual

With every order of ARCO TUBES for \$6.00, or multiple thereof, you can get one, two, or three Auto-Radio Service Manuals absolutely FREE.

If you prefer, you can have copies of the 1934 Official Radio Service Manual FREE with orders for both Manuals for orders of \$13.00. Remember that the regular list price of the 1933 Auto-Radio Service Manual is \$2.50 and the 1934 Official Radio Service Manual, \$3.50.



THIS OFFER IS SUBJECT TO WITHDRAWAL WITHOUT NOTICE.

Complete Stock Ready for Immediate Shipment

Order from this page—Receipt 20% with order, balance C. O. D. All prices are F.O.B. FACTORY, Newark. Shipments to forward address of Parcel Post. No order for less than \$5.00 accepted.

| Type | Voltage | Description | Your Cost |
|---------|---------|--|-----------|
| UX-201A | -5.0 | Detector Amplifier | \$.30 |
| UX-226 | -1.5 | Amplifier (A-C Filament) | .30 |
| UY-227 | -2.5 | Detector Amplifier (A-C Heater) | .30 |
| UX-171 | -5.0 | Power Amplifier 1/2 amp. | .30 |
| UX-171A | -5.0 | Power Amplifier 1/2 amp. | .30 |
| UX-240 | -5.0 | Voltage amplifier | .40 |
| UX-120 | -3.3 | Power Amplifier | .40 |
| UX-199 | -3.3 | Detector amplifier | .40 |
| UV-199 | -3.3 | Detector amplifier short plug | .40 |
| UV-199 | -3.3 | With a standard 2 1/2 A base | .40 |
| UX-112A | -3.0 | Amplifier detector 3/4 amp. | .40 |
| UX-112 | -5.0 | Amplifier detector 3/4 amp. | .40 |
| UX-200A | -3.0 | Detector | .40 |
| UY-224 | -2.5 | Screen grid R-F amplifier (A-C Heater) | .40 |
| UX-245 | -2.5 | Power amplifier (A-C Filament) | .40 |
| UX-201B | -5.0 | Detector amplifier 1/2 amp. | .60 |
| UY-246 | -2.5 | Dual Grid Power amplifier (A-C Fil.) | .60 |
| UY-247 | -2.5 | Power amplifier pentode (A-C Fil.) | .60 |
| UY-257 | -2.5 | Power amplifier pentode (D-C Fil.) | .65 |
| WD-11 | -1.1 | Detector amplifier | .60 |
| WD-12 | -1.1 | Detector amplifier | .60 |
| UX-230 | -2.0 | Detector amplifier | .60 |
| UX-231 | -2.0 | Power amplifier | .60 |
| UX-232 | -2.0 | Screen grid radio frequency amplifier | .60 |
| UY-233 | -2.0 | Power amplifier pentode | .65 |
| UX-234 | -2.0 | Super-control R-F amplifier pentode | .65 |
| UY-235 | -2.5 | Super-control R-F Amp. (A-C Heater) | .60 |
| UY-236 | -0.3 | Screen-Grid R-F Amp. (A-C Heater) | .85 |
| UY-237 | -0.3 | Detector amplifier (A-C Heater) | .85 |
| UY-238 | -0.3 | Power amplifier pentode (A-C Heater) | .85 |
| UY-239 | -0.3 | R-F amplifier pentode (A-C Heater) | .85 |
| UY-251 | -0.3 | Super-control R-F Amp. (A-C Heater) | .60 |
| 2A3 | -2.5 | Power amplifier triode (A-C Heater) | 1.10 |
| 2A7 | -2.5 | Pentagrid converter (A-C Heater) | 1.10 |
| 2B7 | -2.5 | Duplex-Diode Pentode (A-C Heater) | 1.10 |
| 6A7 | -0.3 | Pentagrid Converter (A-C Heater) | 1.10 |
| 6B7 | -0.3 | Duplex-Diode Pentode (A-C Heater) | 1.10 |
| 2A5 | -2.5 | Power amplifier pentode (A-C Heater) | .85 |
| 41 | -0.3 | Power amplifier pentode (A-C Heater) | .60 |
| 42 | -0.3 | Power amplifier pentode (A-C Heater) | .60 |
| 43 | -25.0 | Power amplifier pentode (A-C Heater) | .85 |
| 44 | -0.3 | R-F amplifier pentode (A-C Heater) | .85 |
| 48 | -30.0 | Power amplifier Tetrode (D-C Heater) | 1.10 |
| 49 | -2.0 | Dual Grid power amplifier | .85 |
| 55 | -2.5 | Duplex-Diode Triode (A-C Heater) | .60 |
| 56 | -2.5 | Super-Trio de amplifier (A-C Heater) | .60 |
| 57 | -2.5 | Triode-grid detector Amp. (A-C Heater) | .60 |
| 58 | -2.5 | Triode-grid R-F amplifier (A-C Heater) | .60 |
| 59 | -2.5 | Triode grid power Amp. (A-C Heater) | .60 |
| 75 | -0.3 | Duplex-Diode Triode (A-C Heater) | .85 |
| 76 | -0.3 | Triode-grid R-F amp. (A-C Heater) | .85 |
| 78 | -0.3 | Class B Twin amplifier (A-C Heater) | .85 |
| 79 | -0.3 | Duplex Diode Triode (A-C Heater) | .85 |
| 89 | -0.3 | Triode grid power Amp. (A-C Heater) | .60 |
| P2N | -2.5 | Power amplifier pentode (A-C Heater) | .85 |
| UX-220 | -2.5 | Power amplifier oscillator (A-C Heater) | 1.10 |
| UX-222 | -3.3 | Screen grid radio frequency amplifier | 1.10 |
| UX-257 | -2.5 | Power amplifier (A-C Filament) | 1.10 |
| UY-227A | -2.5 | Detector amplifier (quick heater) | .60 |
| UY-224A | -2.5 | Screen grid R-F amplifier (quick heater) | .60 |
| UX-184 | -5.0 | Sparton type power Amp. (A-C Fil.) | .85 |
| UX-185 | -2.5 | Sparton type power Amp. (A-C Heater) | .85 |
| UY-486 | -3.0 | Sparton type detector Amp. (A-C Heater) | .85 |
| UY-486 | -3.0 | Sparton type power Amp. (A-C Fil.) | 2.10 |
| UY-686 | -1.0 | Sparton type amplifier | .85 |
| UX-401 | -3.0 | Kellong type triode (A-C Heater) | 1.50 |
| UX-403 | -3.0 | Kellong type output triode (A-C Heater) | 2.00 |

RECTIFIER AND CHARGER BULBS

| | |
|---|-------|
| 125 Mill. rectifier tube B.H. (Raytheon type) | 1.25 |
| 6-10 Amp. trickle charger Bulb (Tungar type) | 2.00 |
| 2 Amp. charger Bulb (Tungar type) | .60 |
| 5 and 6 Amp. charger Bulb (Tungar type) | 3.75 |
| 15 Amp. charger Bulb (Tungar type) | 7.50 |
| 1 | 2.75 |
| 1 | .85 |
| UX-280M | 1.10 |
| UX-280 | 1.10 |
| UX-871 | 1.10 |
| UX-280 | .40 |
| 25Z5 | .85 |
| 25Z5 | .85 |
| UX-281 | 1.10 |
| UX-281 | .85 |
| UX-283 | .85 |
| UX-218B | .85 |
| UX-218 | .85 |
| UY-84 | .85 |
| UX-872 | 11.00 |

Specifications and quotations on PHOTOLECTRIC CELLS, TELEVISION TUBES, TRANSMITTER TUBES, CRATER TUBES, HIGH VACUUM TYPE CATHODE RAY TUBES suitable for television and standard oscillographic uses, SUBMITTED ON REQUEST.

ARCO TUBE COMPANY
38-S Park Place Newark, N. J.

Skeptical of Short Waves? we actually Guarantee Results



BUY GUARANTEED

These Are Fool-Proof Short-Wave Sets

And here are letters from those who have actually tried these Short-Wave sets:

THE OSCILLODYNE

HOW IT WORKS

I have constructed the OSCILLODYNE RECEIVER and boy! how it works!

The first day without any trouble I received Spain, England, France, and other foreign countries. Amateurs! why I never knew there were that many until now. With the one tube Oscillodyne, I bring in more stations on one plug-in coil than with a set of coils on different short-wave sets.

IF ANY ONE IS TRYING HIS LUCK ON SHORT-WAVE SETS, IT WILL BE WORTH WHILE TO CONSTRUCT THE ONE TUBE OSCILLODYNE.

PAUL KORNEKE, JR., N. S. Pittsburgh, Pa.

A PEACH

The oscillodyne receiver, believe me is a "peach." I get short-wave stations from Germany, France, Spain and Italy—not to mention the American stations, including amateurs all over the United States.

I heartily recommend this set to any Short-Wave fan. HENRY TOWNSEND, Ramsey, N. J.

THE DOERLE RECEIVERS SOME LIST

Have just completed your Doerle two-tube. I received the following on the loudspeaker: XDA, IQA, GMB, VE9DR, VE9GW, KKQ, WIXAZ, W2XAF, W3XAL, W3XAU, W8XK, W8XAL, W9XF, W9XAA; Bermuda, Honolulu, Budapest, Hungary, and "hams" in 38 states.

MAURICE KRAAY, R. F. D. 1, Hammond, Ind.

THIS IS GOING SOME!

Today is my third day for working the Doerle set, and to date I have received over fifty stations. Some of the more distant ones I shall list. From my home in Maplewood, N. J., I received the following: WVR, Atlanta, Ga.; WJK, Ohio; W9BHM, Ft. Wayne, Ind.; W9AYB, Elgin, Ill.; W8ERK, Girard, Ohio; and best of all, XDA, Mexico; PZA, Surinam, South America; TIR, Cartago, Costa Rica; G2WM, Leicester, England. I have also received stations WJC and PJQ, which I have not found listed in the call book.

JACK PIOR, 9 Mosswood Terrace, Maplewood, N. J.

A DOERLE ENTHUSIAST

I have just completed my two-tube Doerle, and it sure is a great receiver! It works fine on all the wave bands. Nobody could wish for any better job than this one. I can get W8XK and W9XAA to work on the loudspeaker at night, and the code stations come in with a waftor behind them.

SAMUEL E. SMITH, Lock Box 241, Graving, Mich.

FRANCE, SPAIN, ETC., ON LOUDSPEAKER

I hooked up my two tube Doerle Kit and I received France, Rome, Spain, Germany and England on the loudspeaker as well as over 100 amateur phone stations.

I am very pleased with the receiver and would not part with it for anything. I have listened to many factory built short-wave receivers, but believe me, my DOERLE is the set for me.

ARTHUR W. SMITH, Springfield, Mass.

REGULAR FOREIGN RECEPTION

A few days ago, I purchased one of your TWO TUBE DOERLE WORLD WIDE SHORT WAVE RECEIVERS. I just want to tell you that this set does all you claim. In the short time I have had the set, I have brought in stations in England, Germany, France and South America, Devonshire, England, and Nauem, Germany can be picked up daily with very strong volume. THE DOERLE IS A FINE SET.

ARTHUR C. GLUCK, Brooklyn, N. Y.

THRILLED BY DOERLE PERFORMANCE

I am very much pleased with the DOERLE S.-W. radio I received; the local amateur stations come in loud and clear. The first foreign station I received was DJA, Zeesau, Germany. I certainly received this station with a thrill. Yours for success.

RANDOLPH GRAY, Quincy, Mass.

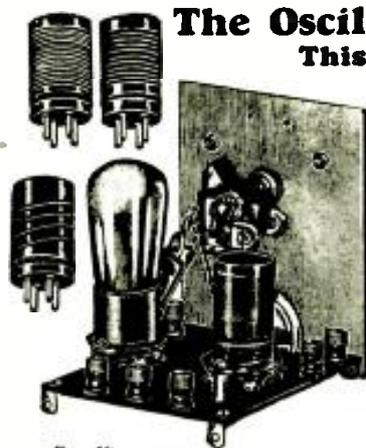

Rear View

The Oscillodyne 1 Tube Wonder Set This Is The Ideal Beginner's Set

If you have never operated a short-wave set before, this is the one with which to start! If, on the other hand, you are already a hard-boiled short-wave fan (and are therefore aware of the shortcomings of the average short-wave set), the Oscillodyne is the set which will instill you with new confidence. It is a set which will convince you that foreign stations CAN be tuned in whenever they are on the air. We have acquired the sole rights from the publishers of Short Wave Craft to manufacture exclusively the Official Oscillodyne 1 Tube Set, as described in the April 1933 issue. Read what the editor of Short Wave Craft says in that issue:

A REALLY NEW CIRCUIT

We are pleased to present to our readers an entirely new development in radio circuits. Under the name of the "Oscillodyne," Mr. J. A. Worcester, Jr., has developed a fundamentally new circuit. This circuit which is of the regenerative variety, acts like a super-regenerative set although it does not belong in that class. Its sensitivity is tremendous. The editor, in his home on Riverside Drive, New York City, in a steel apartment building, was able to listen to amateurs in the Midwest, using no aerial and no ground. With the ground alone, a number of Canadian stations were brought in, and with a short aerial 140 feet many foreign stations were easily pulled in.

Here, then, is a set which brings in stations thousands of miles away; a set which frequently brings in Australia, loud enough to rattle your phones, and with power to spare; a set which, if you do not wish extreme distance, will bring in stations several thousand miles away without aerial or ground.

ABSOLUTELY FOOL-PROOF

This set, as we sell it, may be had either completely wired, or in kit form. There is absolutely nothing to go wrong with the Oscillodyne. Simple directions and blueprints show you how to build and operate the set for best results. It may be used either on A. C. or with batteries. If A. C. is employed, a type 227 tube is used in conjunction with a suitable A. C. power pack (such as the one listed on the opposite page.) 2 1/2 volts will be required for the filament of the tube, and 90 volts for the plate. If batteries are employed, a 227 tube should be used in conjunction with either a storage battery or four No. 6 dry cells and two 45 volt B batteries.

Oscillodyne Wonder Set

The set is exactly as illustrated here, size of aluminum panel is 8" high by 4 1/2" wide, base 5 1/4" long by 4 1/4" wide. List of materials used:
 No. 2146. Official One-Tube Wonder Set, completely wired and tested as per above specifications. **\$6.19**
 YOUR PRICE.
 No. 2147. Official One-Tube Wonder Set, but not wired, with connections and instructions for operation, complete shipping weight 3 lbs. YOUR PRICE, **\$5.34**
 No. 2148. COMPLETE ACCESSORIES, including the following: one 6 month guaranteed Neutron No. 237 tube, one set No. 1878 Brandes matched headphones; four No. 6 Standard dry cells; two standard 45-volt "B" batteries, complete shipping weight 22 lbs. YOUR PRICE, **\$5.09**

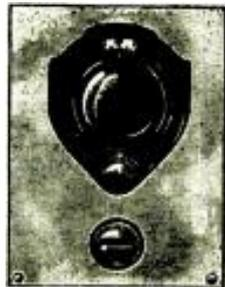

Front View

The Oscillodyne 2 Tube Loudspeaker Set NO PLUG-IN COILS

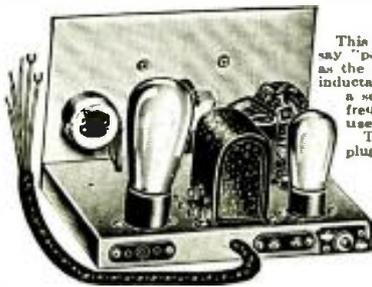

Rear View

This receiver is one of the most powerful 2-tube sets ever built, and when we say "powerful," we mean powerful! It employs the same Oscillodyne circuit as the receiver listed above, but differs from that set mainly in that a tapped inductance coil covering the entire short-wave range is employed rather than a set of short-wave plug-in coils. Furthermore, a powerful stage of audio frequency amplification has been added so that a loudspeaker can be used on practically all stations.

The use of a tapped inductance coil does away with the necessity for using plug-in coils, to which many people object. It is only with a set of the Oscillodyne type that a tapped inductance can be used inasmuch as the "losses" introduced do not seriously interfere with the operation of the set. In other receivers, these very same "losses" may well spell the difference between success or failure of operation. Under actual test, we have picked up signals half way round the world—12,500 miles—on the loudspeaker. Station VK3ME, Melbourne, Australia, was intercepted and reproduced on the loudspeaker without interruption and with excellent fidelity. Station EAQ, Madrid, Spain, and many other foreign stations were received regularly, night after night. There is no question but what this set will work in all parts of the country, under practically all conditions.

Only parts of the highest quality, such as Hammarlund condensers, Yaxley switches, Kurl Knoch vernier dials, etc., have been used. These parts are mounted on a sturdy cadmium-plated metal chassis which measures 9" long x 6 1/4" wide x 6" high.

No. 2197. 2-Tube Oscillodyne Loudspeaker Set, Completely wired and tested. Ship. wt. 9 lbs. **\$10.84**
 YOUR PRICE.
 No. 2199. Complete accessories for this receiver, including 1—type 55 tube, 1—type 47, 1—special short-wave hum-free AC power pack, No. 2149; 1—type 280 rectifier tube for the power pack; 1—B. B. I. magnetic loudspeaker. Ship. wt. 14 lbs. **\$11.19**
 YOUR PRICE.

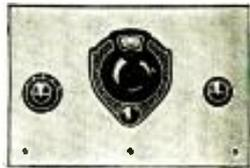

Front View

FREE SHORT-WAVE BOOKS YOUR CHOICE

of either one of books illustrated herewith—FREE OF CHARGE—with the purchase of any of the short-wave receivers listed in this advertisement.

Book No. 866 explains in a most thorough-going manner the ways and means of obtaining an amateur transmitting license. Furthermore, all government rules regulating amateur transmissions are reviewed. Book 830 is a comprehensive and thorough compilation of the most prominent short-wave receiver circuits published during a period of two years. Build up your radio library with one of these books.



Book No. 866



Book No. 830

Order from This Page

Send money order or certified check. C. O. D. only, if 20% remittance accompanies all orders. Order NOW—TODAY.

RADIO TRADING COMPANY, 100A Park Place, New York City

SHORT WAVE SETS

Sets Which Work At Your Command

And NOW The *Electrified* Official Doerle



2-Tube 12,500 Mile Doerle Set Rear View—Both A. C. and 2-Volt Models look alike

2 And 3 Tube Receivers

Operate On Either A. C. or Batteries—May Also Be Had For 2-Volt Operation



3-tube Doerle Signal Gripper REAR VIEW of A. C. Model—2-volt Model does not have Tube Shields.

Only \$14.19

Short-wave receivers have come and gone, but never have there been produced short-wave receivers which have taken the entire country by storm as have the famous Doerle Receivers.

And Now These Doerle Sets Have Been Completely Electrified

Mr. Doerle described his first receiver, the now famous 2 TUBE 12,500 MILE RECEIVER in the Dec.-Jan. issue of *Short Wave Craft*, and his 3 TUBE SIGNAL GRIPPER in the Nov. 1932 issue.

If you are a reader of this magazine, you have undoubtedly been surprised at the great number of fan letters published in *Short Wave Craft*, praising these receivers to the skies—and for good reasons! We have sold many hundreds of these sets, and they are still going strong.

They are low-priced, yet pull in short-wave

stations from all over the world REGULARLY, in practically ANY LOCATION, not only in this country, but anywhere! popular with people living in rural districts where electric service is scarce.

For the thousands of fans however, who enjoy the benefits of electric service, we have developed the 2 and 3 Tube A.C. Doerle sets. These sets, employing the latest type triple-grid tubes, are naturally more sensitive and infinitely more sensitive than the original Doerle receivers.

Furthermore, not only can they be used on alternating current, but with batteries as well. The 2 tube 12,500 Mile Electrified Doerle Receiver employs a type 57 triple-grid detector tube, which is resistance-coupled to the type 58 output tube. For operation on batteries the 57 is replaced with a 77-tube and the 58 with a 37. This set actually works a loudspeaker on all local and many distant stations. The 3 Tube Electrified Doerle Signal Gripper employs a 58 triple grid tube as a radio-frequency amplifier, followed by a type 57 detector, and finally, a 58 output tube. For battery operation the Tys 78, 77 and 37 tubes are used. This receiver, in its sensitivity and DX ability, equals many expensive 5 and 6 tube short-wave sets.

Improved Circuit and Design

Despite the remarkable performance of the Doerle receivers, our technical staff felt that they could obtain better results by making slight modifications of the circuit. This is especially true of the 3 Tube Signal Gripper, both the new A.C. and 2-volt models. In the 2-volt model, the first type 30 R. F. tube was replaced by a type 34, which is a special-purpose screen-grid R. F. amplifier. In the A. C. model, a type 58 triple-grid, high-gain R. F. tube is employed. Furthermore, in this latter model the Antenna trimmer condenser has been eliminated through the use of inductive coupling. The detector plug-in coils are of the six-prong type, each having three separate windings. This means that the R. F. Stage is inductively coupled to the detector. Yet, despite these various changes, we have not increased the price of these receivers, to you.

By special arrangements with the publishers of *Short Wave Craft*, we have been given the exclusive right to manufacture and sell the Official Doerle Receivers, both the earlier 2-volt and the latest A. C. models—so that now, all short-wave enthusiasts who have ever wished to own any of these fine sets can buy them without the slightest doubt in their mind but that they will perform 100%. This means that all the usual "bugs" have been ironed out by us in such a way that in practically every location, anywhere, they will "do their stuff."

Only First-Class Parts Are Used

It may be possible to buy the parts or completed sets at a lower price—we admit this at once—but without concern. For we have used only the best parts available in the construction of our sets. We have done away with all usual "losses" which are incidental to the use of poor components. In these receivers, only the best tuning condensers, and that means Hammarlund—are used. These sets could be introduced for a considerably less amount if we used cheaper condensers. We refrained from doing so, however, because then we COULD NOT GUARANTEE RESULTS! And this goes for everything else in these sets. . . .

If you are skeptical of the results obtainable with these receivers, read the letters from our many short-wave fans and friends printed on the opposite page.

Our Own Tests

Every one of these Doerle receivers, without exception, is tested in our Laboratory under actual operating conditions. We refrain from giving you the astonishing list of stations which we ourselves have logged during the course of our tests; for we do not wish to let our enthusiasm run away with us! We would much rather have you and our many other short-wave friends talk about the results. Incidentally, we have yet to receive a single complaint on any of these sets although we have sold many hundreds of them. Each receiver is accompanied by schematic diagram and wiring blueprint, as well as a pamphlet of detailed instructions.

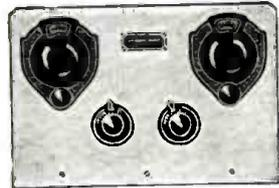

FRONT VIEW Showing general appearance of all Doerle receivers



Special Short-Wave Power Pack

Designed Especially For The Doerle Receivers

Everyone knows that an A. C. short-wave set is no better than the power back which supplies its power! A power supply for short-wave use must be constructed with extreme care. It must be absolutely free from hum or other disturbances caused by insufficient filtering, poor wiring, or faulty equipment.

This unit has a two-section filter circuit, employing two-heavy duty 30 Henry chokes and a tremendous amount of capacity. This assures PURE D. C. with practically no ripple at all.

The power pack supplies 250 volts at 50 mills for the plates of the tubes, 22½ volts for the screens, and 2½ volts at 5 amperes for the filaments. These various voltages are obtained from convenient binding posts on the side of the pack. Furthermore, provisions are made for energizing the field of a dynamic speaker. Any speaker having a field resistance of from 1500 to 2500 ohms may be thus energized. All the component parts of this pack are built into a sturdy, metal base which is black, crackle finished. The power transformer and one of the chokes are the only units which are mounted on top of the chassis. The pack employs a type 280 full-wave rectifier which is inserted in a socket on top of the base. A convenient on-off switch is mounted on the side. The pack is sold complete with four feet of connecting cord, terminating in a special Belden soft rubber plug. Measures 7½" long x 4" wide x 4¾" high overall. Sold complete with 280 tube. Ship wt. 10 lbs.

No. 2149 Short-Wave Power Pack, including 280 tube \$6.24

FREE CATALOG
116 page Radio and Short Wave Treatise. 100 hook-ups, 1,000 Illustrations. Enclose 4c for postage. Treatise sent by return mail.

| SPECIFICATIONS | |
|----------------|--|
| No. 2174. | Electrified 2 Tube 12,500 Mile Doerle Receiver, completely wired and tested, less tubes. Measures 9" long x 6" high x 8½" wide. Shipping wt. 5 lbs. \$9.44 |
| YOUR PRICE | |
| No. 2175. | Electrified 2 Tube 12,500 Mile Doerle Receiver in kit form, less tubes, but including blueprints and instructions. Ship. wt. 5 lbs. \$8.24 |
| YOUR PRICE | |
| No. 2176. | Complete set of tubes for above; either one—57 and one—58 for A. C. operation, or one—77 and one—37 for battery operation. \$1.79 |
| YOUR PRICE | |
| No. 2177. | Electrified 3 Tube Doerle Signal Gripper, completely wired and tested; less tubes. Measures 10½" long x 7" high x 8½" wide. Ship. wt. 7 lbs. \$14.19 |
| YOUR PRICE | |
| No. 2178. | Electrified 3 Tube Doerle Signal Gripper in kit form, including blueprints and instructions; less tubes. Ship. wt. 7 lbs. \$12.74 |
| YOUR PRICE | |
| No. 2179. | Complete set of tubes; either one—58, one—57 and one—58 for A. C. operation or one—78, one—77 and one—37 for battery operation. \$2.69 |
| YOUR PRICE | |
| BATTERY SETS | |
| No. 2140. | TWO TUBE 12,500 MILE 2-VOLT DOERLE SHORT WAVE RECEIVER, completely wired and tested. Ship. wt. 5 lbs. \$8.89 |
| YOUR PRICE | |
| No. 2141. | TWO TUBE 12,500 MILE 2-VOLT DOERLE SHORT WAVE RECEIVER KIT, with blueprint connections and instructions. Ship. wt. 5 lbs. \$7.69 |
| YOUR PRICE | |
| No. 2142. | COMPLETE ACCESSORIES, including 2 No. 230 tubes; one set of Brandes Headphones; 2 No. 6 dry cells; 2 standard 45-volt "B" batteries, complete, ship. wt. 22 lbs. \$5.39 |
| YOUR PRICE | |
| No. 2143. | THREE TUBE 2-VOLT DOERLE SET, completely wired, ready to use \$11.84 |
| YOUR PRICE | |
| No. 2144. | THREE TUBE 2-VOLT DOERLE SET IN KIT FORM, with blueprint connections and instructions. Ship. wt. 7 lbs. \$10.49 |
| YOUR PRICE | |
| No. 2145. | COMPLETE ACCESSORIES, including 2 No. 230 tubes; and one type 34, one set of Brandes Headphones; 2 No. 8 dry cells; 3 standard 45-volt "B" batteries; 1 B. B. L. 9 inch Magnetic Loudspeaker. Shipping weight 32 lbs. \$10.99 |
| YOUR PRICE | |

EXTRA SPECIAL

Baird Universal Short Wave and Television Receiver

Seven Tubes—15 to 500 Meters
Only 20 at This Price

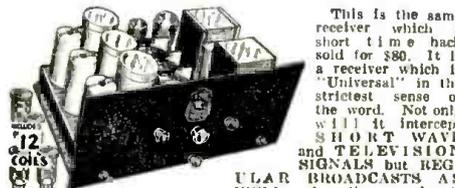

This is the same receiver which a short time back sold for \$80. It is a receiver which is "Universal" in the strictest sense of the word. Not only will it intercept SHORT WAVE and TELEVISION SIGNALS but REGULAR BROADCASTS AS WELL. In other words, it will receive practically everything which is on the air below 550 meters. Amazingly simple in construction, marvelously proficient in performance. The set employs 7 tubes, namely: 3-24's; 2-27's; 1-45 and 1 B.H. rectifier. Provisions are made for connecting a television neon tube and for switching from loudspeaker to television. A complete complement of 12 plug-in coils is furnished with the set. These coils cover a range of from 15-200 meters. Three additional coils to cover the broadcast range of from 200-550 meters can be furnished at an additional cost of \$1.00 per coil. Provisions are also made for carbon reception as well as for a phonograph pick-up connection. Only high grade parts such as Hammarlund condensers, etc., are used. The chassis is completely wired and assembled ready to use and is CONTAINED IN A HANDSOME MAHOOGANY CABINET. The supply of these sets is very limited, being only twenty in all. Act fast if you desire to take advantage of this offer. Shipping weight, 65 lbs. **\$80.00**

LIST PRICE \$80.00
No. 35 Baird Universal Short Wave and Television Receiver **\$22.50**
YOUR PRICE **ONLY**

RADIO TRADING COMPANY, 100A Park Place, New York City

A REAL S. W. GLOBE



A Man's-Sized Globe for Short-Wave Fans

Here, at last, is the most marvelous globe bargain of the world. It's a big fellow, as you can see in comparison with the standard telephone set. The globe measures 12 inches in diameter, and the total height, with pedestal, is 16 inches. The globe is printed in some fourteen different colors, and is waterproof, so that it can be washed without trouble. The "Meridian" in which the globe moves is made of highly polished and nickel-plated metal, while the base is a beautiful dull black. A simple lock "A" makes it possible for you to change the angle of inclination, for easier inspection and measurement. Only the best of material is used in the making of this globe, and this is the first time that a large globe of this kind has been sold at such an extremely low price.

Only with a world globe of this kind is it possible to get a true picture of the relation of countries to each other, air-line distances, etc. For instance, which is nearer to New York—Moscow, Russia, or Rio De Janeiro, Brazil? Capetown, South Africa, or Tokio, Japan? Honolulu, Hawaii, or Lima, Peru? You will be amazed when you actually come to measure the distances. This is best done by stretching a string over the globe, in such a way that it passes directly over the two cities or two points in question. Not only is a flat map deceptive but, when it comes to distance, it is all wrong. *The true measurements can be made only on a globe.* This globe is big enough to give your den or room a professional appearance; and those who own them would not part with theirs.

The low price we are quoting is for introductory purposes; it must be increased in a short time.

The World Short-Wave Globe, as illustrated, 12-inch diameter, 16 inches high. Authentic, up-to-date (published late 1932); over 7,500 names and places—there have been 1362 official changes in the past ten years. Spelling conforms to rulings of U. S. Department of Commerce, and Royal Geographic Society, London, England. Names as they are spelled by

HOW TO ORDER

Send money order, certified check or check (be sure to register letter). Enclose sufficient money for parcel post otherwise must ship express collect. Shipping weight 8 lbs.

their local broadcasters. Washable lacquer finish; movable-meridian style of mounting. Smart modern base design in black, polished nickel meridian. All globes are packed in a carton for safe shipment, and we guarantee delivery in perfect condition to you. List price, \$12.50. Your Special Price..... **\$3.75**

SHORT WAVE CRAFT

98 Park Place

New York City

SPECIAL To SHORT WAVE READERS

For a limited time only, and as long as they last, we will send you six back numbers of SHORT WAVE CRAFT assorted, your choice, for 85c. The usual price for six copies would be \$1.50 and most publishers charge a higher price for back numbers over one year old.

We can supply all copies except the following: June-July, Aug.-Sept., 1930; Dec.-Jan., Feb.-Mar., April, May, June, July, Oct., 1932.

If you do not specify copies

Short Wave Craft,
96 Park Place,
New York, N. Y.
Gentlemen: I enclose herewith 85c for which you are to send me six back number copies of SHORT WAVE CRAFT as follows:.....
Name.....
Address.....
City..... State.....
SWC1033

we will use our own judgment in sending assorted numbers to fill your order. Note we cannot exchange the copies for ones that have been sent to you.

Practically every copy of SHORT WAVE CRAFT contains important information that you should have. Here is a chance to get those copies.

As we have only a small supply of back numbers on hand, this offer will be withdrawn as soon as they have been sold.

We accept U. S. stamps, U. S. coin or money order. Rush your order today.

SHORT WAVE CRAFT, 96 Park Place, New York, N. Y.

The Evolution of Ultra Short Waves

(Continued from page 365)

question. This time period is in its turn dependent upon the distance between those electrodes, and inversely proportional to the voltage between them. Since (under the same operating conditions) the distance between the grid and plate is less than that between the cathode and plate, the former method of oscillation gives rise to the shorter waves.

The R.F. potentials set up in the external circuit by the oscillating electron clouds may influence, via the changes of potential upon the electrodes, the time of swing. The result of this appears to be that in some circumstances the constants of the external circuit can affect the period of swing and therefore the wavelength, whilst in other circumstances this is determined solely by the geometry of the tube and the operating potentials, the constants of the external circuit merely affecting the output, by resonance with the electron oscillations. In the former case the type of oscillation is referred to as the "Gill-Morrell," and in the latter case as the "Barkhausen-Kurz," from the names of the two investigators who in each case first demonstrated that particular type of oscillation. It is not easy to predict which type of oscillation will be produced in any particular case, but it may be said that in general a perfectly symmetrically constructed tube and low operating potentials will predispose to Barkhausen-Kurz oscillations, whilst a slightly unsymmetrical tube with high operating potentials will predispose to oscillations of the Gill-Morrell type. Oscillations of both types may co-exist simultaneously.

Referring to the practical side of the question, there is one rather serious drawback to the electron-oscillation method, i.e., it is very hard on the tube, as anyone might surmise who has had any experience of valves using high positive grid potentials. Consequently, only tubes of the "bright emitter" type will stand up to the work for any length of time. For experimental purposes it is best to choose a small bright-emitter transmitting tube of robust and symmetrical construction. Voltages of from +200 to 300 volts may be applied to the grid, and from 0 to minus 100 to the plate. A sudden change in the reading on the plate-current meter (M, Fig. 8) will indicate that oscillation has commenced, when the bridge can be moved along the wires until maximum output is obtained, usually indicated by maximum reading on M. (In some cases of B-K oscillations there may be no indication at all on the meter M, whether the circuit is producing maximum available output or not. In these cases the indication is that the electron clouds are not actually reaching the plate, but are oscillating backwards and forwards about the grid.)

The Lecher wires (W, W, Fig. 8) may conveniently be anything from 50 to 100 cm. in length and about 5 cm. apart. (2.54 cm. = 1 inch.) The stopping condenser C may be of any value between 0.0001 and 0.001 mf. Oscillations of the B-K type do not necessarily produce oscillatory current in the plate circuit, so the plate circuit wire may be omitted, and the bridge wire substituted by a copper disc of 20-30 cm. diameter arranged to slide along it, as shown at D in Fig. 10. This form of the circuit is generally found to be very successful, and was originally devised by Pierret.

Still another form is shown in Fig. 11, in which the wire takes the form of a little vertical (approximately quarter-wave) "aerial" attached to the grid terminal. Oscillations having been obtained by adjustments of the tube electrode voltages, the wire is adjusted in length until maximum output is obtained.

With suitable tube obtainable in this country the wavelengths obtained will gen-

The "RT" Beginner's Transmitter

(Continued from page 343)

The power supply to operate the above transmitter delivers 400 volts at 150 mills (m.a.) for the plates of the tubes and 2.5 volts for the filaments. A type 83 mercury vapor rectifier is used because of its low voltage drop, which provides very good regulation. A filter consisting of a 30 henry iron core choke with a 2 mf. condenser on either side, produces very good "DC" signal from the transmitter.

Putting the Transmitter on the Air

Getting the transmitter on the air is no difficult task if a few pains are taken in adjustment. After all wiring has been checked carefully to make sure that no

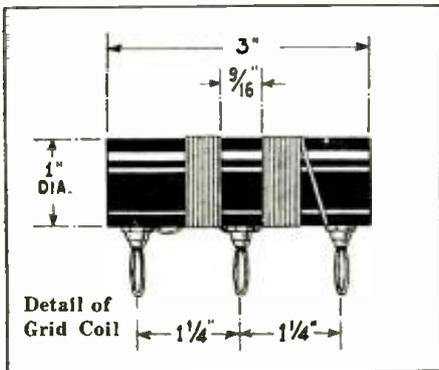

wrong connections have been made, connect the power supply to the oscillator unit, inserting a 0-100 milliammeter in the positive plate voltage lead. It is best to put a resistor in series with this lead also in order to start adjustments with a reduced plate voltage because if the plate circuit is not in resonance with the grid circuit the plate current will be very high and probably damage the tubes or meter. Do all tuning without the antenna connected. Insert all tubes allowing them to heat up sufficiently using the 80 meter coils as a starter, close the key and be prepared to tune the plate condenser *immediately* for lowest plate current as indicated by the meter. When this point has been reached the resistor can be removed from the plate circuit, allowing full plate voltage to be applied to the tubes. The plate current should now be in the order of about 50 milliamperes with no antenna load. All that remains is to check the frequency in the monitor, attach the antenna and we are "on the air."

The antenna suggested for use with this transmitter is the single wire feed Hertz, which was described in September's SHORT-WAVE CRAFT on page 311.

COIL DATA

| Plate Coils | | |
|-------------|-------|-----------|
| Band | Turns | Diameter |
| 160 | 25 | see text |
| 80 | 12 | 2 3/4 in. |
| 40 | 6 | 2 3/4 in. |
| 20 | 4 | 2 3/4 in. |

The 80, 40, and 20 meter coils—1/4 in. copper tubing.

Grid Coils

| Band | Turns | Size Wire |
|------|-------|-----------|
| 160 | 150 | 36 D.S.C. |
| 80 | 78 | 36 D.S.C. |
| 40 | 42 | 26 D.S.C. |
| 20 | 16 | 26 D.S.C. |

All grid coils wound on one-inch diameter bakelite tube, with no spacing between turns.

List of Parts for "Oscillator"

- 1 Set of coils—see coil table
- 1 bakelite tubes 1 inch Dia. 3 inches long
- 12 Banana type coil plugs
- 3 sockets for coil plugs
- 1 50,000 ohm resistor, 5 watts or over (grid-leak) Radio Trading Co.
- 2 4 prong isolantite sockets
- 1 .0005 mf. variable condenser, (receiving type.)
- 3 double binding post strip, (laminated) Radio Trading Co.
- 3 midget stand-off insulators
- 1 baseboard, 7x15 inches
- 2 type 45 tubes

List of Parts for "Power Supply"

- 1 power transformer—2.5, 5, 400-0-400 Radio Trading Co.
- 1 filter choke—30 henries, 150 milliamperes, Radio Trading Co.
- 2 filter condensers—2 mf. 1000 volt rating, Radio Trading Co.
- 1 4 prong socket
- 2 double binding post strips, (laminated) Radio Trading Co.
- 1 baseboard, 7x15 inches

The "Rex" Portable Superhet

(Continued from page 334)

The receiver is mounted in the deep compartment and is recessed down one inch so that the case will close easily. The dropping of the panel is necessary due to the height of the small knobs and the tuning dial.

The coils are plugged in from the front of the panel, with the oscillator coil mounting on the left-hand side, facing the set, and the detector coil on the right-hand side.

A special filament switch is mounted on the panel lower center and this switch is furnished with extra contacts so that the drain on the "C" battery, in the form of the 50,000 ohm volume control, is removed when the receiver is not in operation.

Filamentary control is obtained by means of the 6 ohm rheostat mounted above the oscillator plug-in coil opening. This control takes care of all tubes and is one of the most important units in the receiver, as the life of the tubes is greatly dependent on the proper filament voltage being applied.

The control to the right of the panel and located over the detector tube coil opening is the manual volume control. This control regulates the bias voltage applied to the control grid of the 34 type tube used in the intermediate frequency stage.

Two tank tuning condensers are mounted on either side of the main tuning dial and the constructor should mark off the proper settings, dependent on the band-spread requirements of the operator. The knob to the left controls the oscillator tank condenser and the remaining knob controls the detector tank condenser.

Circuit

A study of the circuit diagram discloses that there are five tubes utilized in this set.

The first tube is the *first detector* and it is mounted upside down in the set. The *intermediate frequency* tube is mounted directly above the first detector tube in an upright position.

Note that grid-leak and condenser rectification is used; this increases the sensitivity of the input stage. Notice that the grid-leak is returned to the chassis; this will prevent the grid circuit from opening when the detector coil is removed from the coil socket. A little thing—but it lengthens tube life.

One *intermediate frequency* stage is used and the intermediate frequency transformers are of the high gain type. The coils of the I.F. transformers are wound with *litz* wire (stranded) and are conventionally double-tuned; i. e., there are four tuned circuits in the intermediate frequency amplifier.

The *second detector* is of the semi-power type, using small values of grid condensers and leaks, resulting in a strong audio-frequency signal output and a higher order of sensitivity than that obtainable with a *biased* second detector.

A high impedance load is used in the plate circuit and consists of an 800 henry iron core choke coil. A suitable condenser and resistor completes the coupling unit connecting the detector tube to the pentode power output tube.

The *oscillator* is very conventional in design and as in the case of the first detector, the grid-leak is returned to the chassis, thus preventing open circuits in the oscillator grid when the oscillator tuning coil is removed.

(Continued on page 377)

Leeds Special Fall Bargains

RCA 2-stage amplifier and power supply employs 1-280, 1-199, 1-171. These amplifiers can be put to a wide variety of uses. The power transformer alone is worth the price of the complete unit, special\$1.50
Inverted electrolytic condensers, 4 mfd.....39c each
8 mfd.....49c each
Bruno condenser microphone kit \$5.88

The new ribbon or "velocity" microphone kit\$5.88
Specials in mounted uncased Kenyon transformers, midget audio transformers for replacement use.....65c each
Push pull input transformers 75c each, push pull output transformers 75c each
245 or 250's to 500 ohm line or 15 ohm voice coil.....75c
Double button microphone transformers85c
30 Henry 75 M A filter choke.....75c
Centralab "Elf" midget volume controls in all popular sizes.....49c each
Amplion adjustable diaphragm loudspeaker units.....\$25.00 list
Super special only.....95c

Headquarters for Short Wave Transmitting and Receiving Apparatus. When in town, visit our store.

MAIL ORDERS FILLED SAME DAY
C. O. D. Orders Must Be Accompanied by 10% Deposit, Include Postage



43-A VESEY STREET
NEW YORK

SHIELDED SHORT WAVE BATTERY SET

17 to 200 Meters

As described in September issue Short Wave Craft

USING 1-30, 1-32, 1-33, 1-34. LOW CURRENT DRAIN INEXPENSIVE TUBES.

COMPLETE KIT of parts with 2 sets of coils (8 coils) \$8.95

With Tubes \$10.95

Completely Wired \$10.95

With Tubes \$12.95

Tubes Guaranteed 3 Months

Foundation Kit, includes 1 Metal Case, 1 Chassis and 1 Shielded Compartment \$2.45

A REAL THRILL IN STORE FOR SHORT WAVE RECEPTION. Get Police reports, Ship-to-Ship and Amateur Conversion, also Short Wave Broadcast Stations.

LEOTONE RADIO COMPANY
63 DEY STREET NEW YORK CITY



"Ham" advertisements are always interesting and profitable to read. See Page 372

Patents—Trade-Marks

All cases submitted given personal attention by members of the firm.

Form "Evidence of Conception" and instructions "How to Establish Your Rights"—Free

LANCASTER, ALLWINE & ROMMEL

Patent Law Offices

434 Bowen Bldg. Washington, D. C.

"HAM" ADS

Advertisements in this section are inserted at 5c per word to strictly amateurs, or 10c a word (8 words to the line) to manufacturers or dealers for each insertion. Name, initial and address each count as a word. Cash should accompany "Ham" advertisements. Advertising for the November issue should reach us not later than September 9.

KRUSE'S RADIOPHONE GUIDE sums up two years of successful trouble-shooting in amateur and commercial voice stations. Yours for 35c. Robert S. Kruse, RFD No. 2, North Guilford, Connecticut.

TRADE OR SELL RECEIVING AND TRANSMITTING parts. Have plug-in coils, etc. What have you? **WIBTE**, Irving Hall, Brockton, Mass.

WANTED! COMET-PRO COMPLETE. LESS tubes; auto radio; phone transmitter. Frank Switalski, 2819 Victoria Ave., Cincinnati, Ohio.

SWAP: BEST OFFER GETS COMPLETE R.T.I. Radio course and radio analyzer. Harry Stengel, 224 Findlay St., Cincinnati, Ohio.

QSL CARDS, NEAT, ATTRACTIVE, REASONABLY priced, samples free. MILLER, Printer, Ambler, Pa.

DIZZY CARTOON FOR QSL OR SHACK. Send \$2 with your rough idea for large original pen drawing. **WIAFQ**, Harwich, Mass.

MIDGET TRANSMITTERS \$2.00 UP. GUARANTEED fone transmitters \$9.50 complete. Code transmitters using any receiving tube, \$4.00 complete. Range over 1500 miles. The Burks Radio Company, 1448 W. Decatur, Decatur, Illinois.

MICROPHONES, AMPLIFIERS, SOUND heads, speakers. What do you need? Bargains. Wells-Smith Radio Corp., 24 N. Wells St., Chicago.

EARN \$2.00 A DAY CONSTRUCTING Radios in your spare time. Send 15c for details. Mr. Lorentz, 453 N. Third St., San Jose, Calif.

QSLs, 50 AND 75 CENTS, W6IID, 5462 Olive Ave., Long Beach, California.

FOR SALE: PHONE TRANSMITTER COMPLETE \$25.00. Will trade for National 5 Receiver. E. Gnakow, W9LSA, Genoa, Illinois.

QSL'S 75c A HUNDRED. 2 COLORS, W9DGH, 1816 Fifth Ave., N. Minneapolis, Minn.

ANGLE RADIATION! R9 SIGS WITH A special antenna! New book gives constructional details and valuable information. New 3-wire feeder system described! Book \$1.00 postpaid. **W6BY**, Arthur L. Munzig, Redlands, Calif.

TUBELESS CRYSTAL SET, SOMETHING new. Separates all stations, operates speaker, 750 miles verified. Blueprint 6 others 25c coin. Modern Radiolabs, 151-A Liberty, San Francisco.

SELL, COOKE 50 LESSON ELECTRICAL course \$5.00, 500 volt, 200 watt power supply \$6.50, P.P., MOPA Xmitter complete, tested, fine for new ham, best offer. Want 32—500 M. G., or 32—110 A.C. converter. W9JAJ, Bellevue, Iowa, R4.

FOR SALE OR TRADE: RCA RADIO Course. Automatic code learning machine with tape. Pilot Universal Wasp, 5 x 7 film or plate camera (Eastman). No. 1-A Anco Readyset Special folding camera. Trickle charger, etc. Want press, mimeograph, etc. Raymond E. Thayer, Gassaway, W. Va.

203A'S \$9.75: NEW FIRST QUALITY AND guaranteed. Amateur Service, Piermount, N. Y.

FOR SALE: NEW 1933 PHILCO Trans-tone Automobile Radios, all electric. Model 5, complete, regular \$39.95, our price \$35.00. Philco Baby Grande Model 80B, regular \$18.75, our price only \$15.00. Model 81B same as 80B, but gets police calls, amateurs, etc., only \$18.00, regular price \$22.50. All brand new. Buy now or never at these low prices. Harry O. Longstreet, 112 Second Ave., Avon, N. J.

QSL'S, STATIONERY, CALLING CARDS, radiogram blanks. Free samples. W9DGS, Jr., Jamestown, N. Dak.

SELL LATE '32 COMET PRO, TUBES, COILS and cabinet. Make cash offer. C. Arnold, Lotus Ave., Oradell, N. J.

PLUG-IN COILS, 15-210 METERS, SET OF four 50c. Noel, 809 Alder, Scranton, Pa.

ANSWER FACTORY HAS SOLVED MANY transmitter and receiver problems. Describe yours and ask for quick quotation, on required advice or diagram. Robert S. Kruse, R. F. D. No. 2, North Guilford, Connecticut.

Amateurs who made good

Robert S. Kruse

● **PERSONAL HISTORY:** Robert S. Kruse, Guilford, Connecticut. Born—Halstead, Kansas, 1892 (August 4th.) School—University of Kansas. Degrees—Bachelor of Science 1917, E. E. 1929.

Radio activity—professional, Western Electric Co., wartime radio work.

Instructor in Radio (Signal Corps School) 1918.

International Tel. & Tel., 1919 in connection with closing out of wartime radio contract materials.

Radio Section, Bureau of Standards, Assistant & Associate Engineer. Mainly on Radio Compass, aircraft landing signals and organization and conduct of fading tests run with American Radio Relay League.

Hammond Radio Research. Field tests in New England and in Mexico on doubly-modulated signals.

Technical Editor QST. Since 1918, Consultant to manufacturers, stations and experimenters. Also Technical Editor and Writer.

Radio activity—amateur.

Station owner since 1908.

Co-organizer of Central Radio Association—once had 1600 members.

800 meter shortrange spark coil work 1909.

190 meter ditto, 10 miles, 1911.
170 meter tube work with Mix and Reinartz 1920-21.

80 meters tube, 10 miles 1921.
1920 Aided in planning and analyzing the Bureau of Standards—ARRL Fading Tests to gain transmission data.

1923, working with Phelps arranged demonstration shortwave tests which were successfully run with cooperation of 9ZN, 3XM, 3ALN, 3JJ, 3APV, 1QP 200 to 145 meters.

1923, first to work European station casually—ACD.

1923-1924-1925 working with Boyd Phelps, F. H. Schnell, Clifford Himoe (9AOG), Clive Meredith (9AQO), Edward Glaser (2BRB), L. W. Hatry (5XV), Harris Hastings (3ALN), W. J. Lee (4XE), John Reinartz (1QP-1XAM), Lawrence Mott (6XAD) and others to feel out shortwave possibilities and to create interest in such work. Many "firsts" were recorded by various participants.

1924 Received first crystal-controlled message (at 1XAQ) from H. S. Shaw, 1XAU, of General Radio Co.

1924 With Meredith, Jones, Briggs, & Phelps made local and field tests to show soundness of Ballantine's theory as to working antennas unloaded—now universal practice.

1924 Member of Committee of ARRL which planned present band system of amateur wavelength assignments.

TRANSFORMERS, CHOKES REWOUND OR built to order. Low prices, quick service, guaranteed. Write for free price list. Boston Transformer Co., 886 Main Street, Cambridge, Mass.

CODE MACHINES, TAPES AND COMPLETE instructions for beginners or advanced students, both codes, for sale or rent reasonable. Rental may apply on purchase price. Extra tapes for all machines. Instructograph, 912 Lakeside Place, Chicago.



Robert S. Kruse

Amateur Transmitters

(Continued from page 341)

The same type of antenna, as was shown last month, namely matched impedance, single-wire voltage-feed, is used on the amplifier.

The *cold point*, however, is now the center of the coil, and the antenna is clipped towards the plate end from this point, until further advance spoils the note.

The oscillator should be carefully placed so it will receive no vibrations from anything in the room. Many an otherwise perfect set has put out a miserable note, *merely because the key was too near the oscillator and was shaking the tank coil!* Mount the oscillator board on a rubber kneeling pad, or rubber sponges.

Tuning Up

1. Clip the excitation lead from the .00025 mf. grid condenser about half-way up from the "cold" end of the oscillator tank, i.e. about two turns for 20, 3½ for 40, and 7 for 80. This excitation adjustment should be increased until an increase does not bring greater output. Never over-excite, as this will ruin the 46 tube.

2. Have the 46 in its socket but remove one of the leads from the Fahnestock clips, to cut off the high voltage. Now place a neon tube on the grid end of the amplifier tank and turn it until R.F. is shown by a reddish glow in the bulb. Then turn the *neutralizing* condenser C4 until the glow goes out. This point is usually found with the condenser almost fully opened. Check this by again tuning the amplifier tank and neutralizing any slight glow remaining. The monitor should be used as a final check of neutralization. With plate current off the P.A., (power amplifier) it should be possible to tune the P.A. tank condenser through resonance without making any appreciable change in the note from the oscillator as heard in the monitor.

3. Now connect the meter and apply voltage to the 46 tube. Tune the tank for minimum current.

4. The antenna is used in the same fashion as on the T.N.T. rig. However, since a more stable unit is supplying power, try for the highest possible output. The transmitter is still keyed in the center tap of the oscillator, as the 46 amplifier does not draw current without excitation.

Will answer letters sent me in care of **SHORT WAVE CRAFT**, provided they contain *stamped, self-addressed envelopes*.

Amplifier Parts List

- 1 Eby socket 4 prong socket
- 1 Eby socket 5 prong socket (46)
- 3 Acratost mica condenser .002 mf. (C1)
- 1 Acratost mica condenser .00025 (C2)
- 1 Acratost 10,000 ohm 5 watt resistor (R1)
- 1 Acratost 50 ohm C.T. resistor (R2)
- 2 Acratost stand off insulators
- 1 Acratost .00035 mf. tuning cond. (C3)
- 2 Hammarlund R.F. chokes type CH500 (RFC)
- 1 Hammarlund .00005 mf. midget cond. (neutralizer) type MC-50-S (C4)
- 2 Fahnestock clips
- 1 Wooden baseboard 7" x 14"

Power Supply Parts List

- 1 Acratost power transformer, giving 500 volts either side of center tap (T1)
- 1 Acratost filament transformer (2.5 volts) (T2)
- 2 Acratost electrolytic filter condensers 4 mf. 1000 volts (C1, C2)
- 1 Acratost choke 150 M.A. 200 ohms D.C. (CH)
- 1 Acratost voltage divider 10,000 ohms 50 watt (R1)
- 2 Eby 4-prong socket
- 1 Wooden base-board 11½" x 9"

1924-25 With Phelps worked eastern end of first shortwave transcontinental circuit—1XAQ-10A-1HX to 9AOG to 6XAD.

1924 On basis of shortwave tests Reinartz-Kruse predicted possibility of 20 meter daylight DX.

1925-28 With Boyd Phelps established most of the present 5 meter records—all the c. w. ones.

Writer of several hundred radio articles; editor of several radio books.

The Propagation of 3 to 8 Meter Waves

(Continued from page 331)

strengths between twenty microvolts and ten millivolts per meter, on frequencies between forty and eighty megacycles. To measure field strengths higher than ten millivolts a low sensitivity loop receiver, shown in Fig. 5, was constructed. It was a simple push-pull rectifier and covered the range from 10 to 400 millivolts. Both receivers were portable and were frequently carried from the automobile to the insides of buildings and residences.

The equipment used in the dirigible was the loop set described above for low sensitivity usage, except that the loop antenna was replaced by a half-wave wire fastened to a bamboo pole. As shown in Fig. 4, this pole was held by the observer sitting near an open door of the cabin and it could be held in any position desired. During flight maximum field strength indication was generally obtained by holding the antenna in a vertical position.

In the autogiro the field strength meter and altimeter were mounted together in front of a 16 millimeter camera, which was focused on the meters. Thus simultaneous recordings of altitude and field strength were readily made photographically.

Observations Made at 280 Miles

The phenomena particularly observed were attenuation, interference patterns, interference noises, service range, interference range, signal fluctuations, and local receiving conditions. Measurements were made by Messrs. Gihring and Turner along radials from the Empire State building in all directions except where water intervened. Two of the radials extended to 100 miles and another to 130 miles. In all cases interference patterns were found to be very common, and the field strength at any point was therefore considered as the average of five minimum and five maximum readings as the car was driven through five successive minima and maxima. Several observations were made at a distance of 280 miles.

Readings were taken inside of suburban homes, city office buildings, and apartment houses. Fluctuations found on the first floors of city buildings were studied by attaching a recording microammeter to the measuring set so that continuous records of the fluctuations would be available. Television receivers were located in about 25 residences or apartments, both in the city and in suburbs, to ascertain the signal strengths required for television reception and to observe the effects of different types of interference.

The autogiro tests were made about sixty miles southwest of New York and were for the purpose of determining variation of field strength with altitude. It was useful for this particular purpose because with its motor shut off it could descend almost vertically. Descent of the ship was fairly regular with no appreciable swaying of the antenna. To eliminate ignition interference the motor was turned off during each descent, a dead-stick landing being made.

Fig. 6 shows the average signal strength of the forty-four megacycles Empire State signal to 130 miles. This curve represents the averages of measurements in several directions. The locations of the points of measurement at distances less than about thirty miles were chosen at random and correspond to average outdoor conditions. The points beyond thirty miles however were selected with an eye to elevation, since the maximum receiving distance was being considered, and therefore the field strengths for these points are somewhat optimistic. The field strength within several miles of the transmitters is more variable than at greater distances. The diversity of the near-by measurements indicates that multi-story steel-reinforced buildings have more influence on the field strength in the street than do the two- or three-story brick and

frame houses further away. On each of the three routes that extended 100 miles or more, the forty-four megacycles signal was heard to the end of the route, whereas the sixty-one megacycles signal was lost between seventy and ninety miles.

Fig. 7 shows the variation of signal strength with distance for the first several blocks from the Empire State building. The maximum signal strength exists approximately three blocks from the Empire State building. The low field intensity existing immediately adjacent to the building is probably caused by the small amount of energy radiated downward by a vertical half-wave antenna.

Effect Within Buildings.

Observations made within buildings indicate considerable attenuation as the signal enters the building. Inside field strengths were from 1/2 to 1/200 of the field strengths immediately outside. At the center of a number of large business buildings there was practically no signal. In such cases, at the side of the building toward the transmitter the signal increased, and similarly at the side of the building away from the transmitter the signal increased. The presence of a good signal on the side of a large building away from the transmitter when no signal could be heard in the center of the building indicated complete absorption of the wave by the building and fairly effective reflection from other surrounding buildings. To check this the receiver was taken to the top of the Woolworth tower. In that case, the signal inside the tower was zero, on the outside of the tower towards the transmitter the signal was very strong, and on the outside of the tower away from the transmitter the signal was zero. This checked with predictions since there are no buildings high enough and near enough to the Woolworth tower to reflect south traveling waves on to the south side of the tower. All observations seemed to show that ultra-short waves are considerably diffused when they reached the buildings of a metropolitan area. This general diffusion or dispersion is probably fortunate since it provides signals on the "shadow" sides of buildings, just as light enters through a window not exposed to the sun.

Observations from the RCA building transmitter were on wave-lengths of 3.5, 5, 6.5, and 8.5 meters. The lesser absorption of the longer waves was clearly observed, also their greater ability to diffract. Behind hills the 6.5- and 8.5-meter waves could be heard fairly well whereas a definite "shadow" would exist for some distance for the 3.5-meter signal. Other experiments were conducted from the RCA building to compare vertical with horizontal polarization but no definite conclusions were reached.

It was observed that at such points as Battery Park, where a large number of steel buildings project themselves between the transmitting and the receiving antennas, the readings were extremely low as compared to readings taken where line-of-sight exists between antennas.

An empirical measure of this attenuation caused by large buildings was obtained in the following manner. A practically identical method was used by Fritz Schroter. Referring to Fig. 8, H is the height of the transmitting antenna, h is the height of the receiving antenna, R is the distance between transmitter and receiver, and d is the height of the absorbing layer. In the case of Manhattan the absorbing layer consists of an agglomeration of large and small buildings. S is the portion of the propagation path in which the wave must travel through or around buildings. We may assume that field strength varies inversely as the dis-

(Continued on page 375)

LYNCH

Short Wave Antenna System
will help you win
the Clifford E. Denton Trophy

CHAS. A. GOEBEL
RADIO
150 95th St. Brooklyn, N. Y.
Shore Road 8-4437

Mr. Arthur H. Lynch, Pres., April 13, 1933,
Lynch Mfg. Co., Inc.,
51 Vesey St., New York, N. Y.

Dear Mr. Lynch:

In the course of our service work, we are frequently told the "Set is noisy." Upon investigation, the noise is usually found to be entering the set via the aerial system. In the form of "Man-Made Static."

After trying various ways and means of eliminating this condition, without success, we finally decided to try out the Lynch Antenna System on a particularly bad case.

The results were more than gratifying: noise eliminated, greater signal input, more stations brought in and better reception generally.

As a result of this experience we have recommended the Lynch Antenna System exclusively and have installed a number of both the Broadcast and Short wave systems with entirely satisfactory results.

Cordially yours,
(Signed) **CHARLES A. GOEBEL**

Complete Kit..... **\$5.00**
At ALL LYNCH Jobbers and Dealers

If your Jobber, Dealer or Serviceman cannot supply you, order direct from us. Sent post-paid, with instruction booklet, for \$3.00.

Free Descriptive Folder Upon Request

LYNCH MANUFACTURING CO., Inc.
51 Vesey Street, New York, N. Y.
Makers of the Famous Metallized Resistors

LEARN AT HOME TO BE A Good Radio Operator



It's Easy

with **THE NEW MASTER**

Teleplex

Code Teaching Machine

Pleasant, interesting work. No experience necessary. We guide you step by step—finish you Complete Code Course and lend you The New Master Teleplex. Teleplex has instructed more students in the code in the past ten years, than all other systems combined. It is the only instrument ever produced that will record your own sending in visible dots and dashes, and then repeat it to you audibly on headphones. (Used by U. S. Army and Navy, R. C. A., A. T. & T. Co. and others. Get started NOW. Low cost, easy terms. Write for folder SW-10 giving full details.

TELEPLEX COMPANY

76 Cortlandt St.

New York, N. Y.

THE "PRIZEWINNER"

As described in June Issue

AC-DC Short Wave Receiver



Completely Self-Powered Latest Type 77.
43, 2523 Tubes 15 to 200 Meters

THE PRIZEWINNER is complete. No extras, such as power supply, coils, etc., to buy. Power supply is built-in and will operate on EITHER AC OR DC! (Four coils included), cover all bands, 2000 KC to 1,500 KC. Complete kit of PRIZE WINNER parts identical in every respect with those used in built-up models, complete in every detail including hardware, hookup wire, solder, coils, etc., and also \$8.95 the cabinet and dial. Price.....

Set of Genuine RCA or Areturus tubes for prize winner..... **\$3.75**

Assembled, wired, tested and enclosed in beautiful crackle finish, or Cadmium Plated metal cabinet ready to plug into your power line. Complete with four coils..... **\$10.95**

Send for full particulars and Diagram

ALAN RADIO CORP., 83 S. Cortlandt St.

New York City

At Last!



OFFICIAL SHORT WAVE LEAGUE LOG AND CALL BOOK

WE ARE happy to present to the thousands of short wave fans this new Log and Call Book, which enthusiastic readers of Short Wave Craft have been urging us to publish. Here is a book that you will feel proud to possess because it reflects your patience and perseverance in logging distant stations. It is a record you will be proud of in days to come. That, however, is not all. The Log and Call Book is the finest and most complete book of its kind ever published. There is nothing like it on the market now, nor was there ever a book published like it before.

Published
Quarterly*

PARTIAL CONTENTS

1. It contains the largest listing of short wave stations in the world, a much larger list in fact than the list published in SHORT WAVE CRAFT, or any other magazine. Due to space limitations, no regular magazine can publish all the world stations. There are so many short wave stations, such as telegraph stations, experimental stations, ship stations, and others, which normally cannot be included in any monthly magazine list, but frequently you hear these calls and then you wish to know from where they originate. The OFFICIAL LOG AND CALL BOOK gives you this information, besides a lot of other information which you must have.
2. A large section of the book is set aside where the calls can be listed in a proper manner. This log section gives the dial settings, time, date, call letters, location, and other information. Thus, when you hear a station, you make a permanent record which is invaluable.
3. Another section has squared-paper pages on which you can fill in your own frequency (wave-length) curve for your particular receiver. This helps you to find stations which otherwise could never be logged by you.
4. A distance chart showing the approximate distances between the principal cities of the world.
5. A meter to kilocycle conversion chart. Many of the short-wave broadcasters announce their frequency in the latter scale when signing off and many listeners do not know the relation between them.
6. A list of international abbreviations used in radio transmission.
7. The complete Continental code used in all radio work.
8. A list of International Call Letter Assignments; Around the Clock Listing Guide.
9. In addition to this, you will find included a map of the world, with time indications and a host of other useful information which aids you in logging distant stations thousands of miles away.

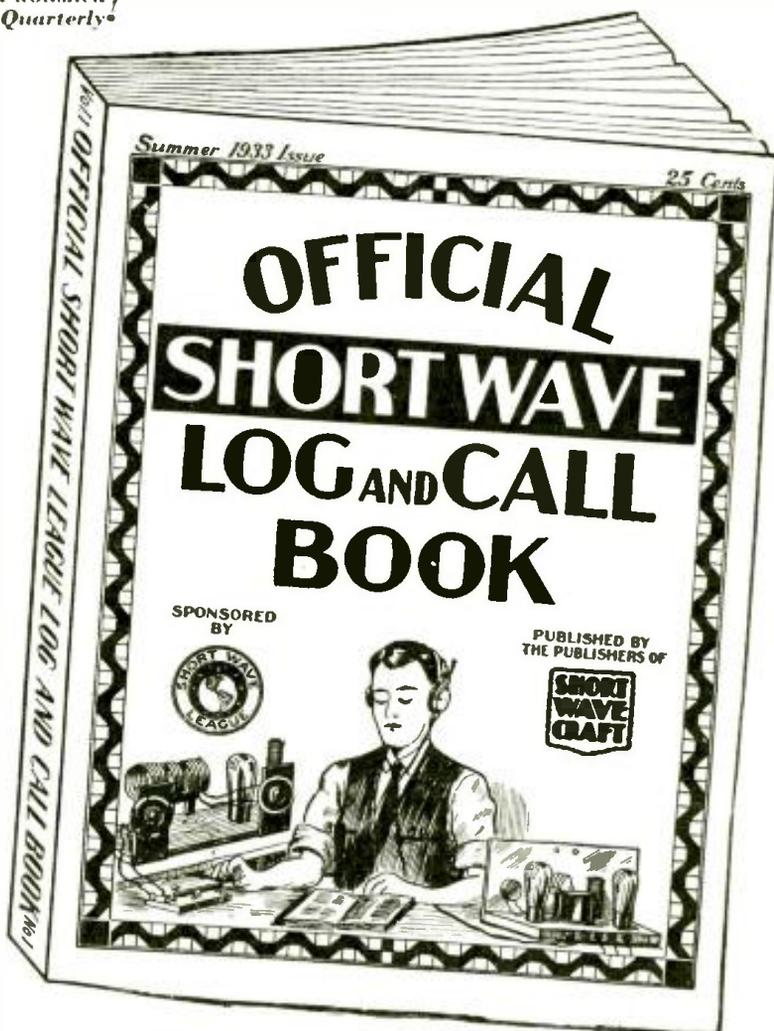

This is one of the finest books that the publishers of SHORT WAVE CRAFT have ever turned out. You will be proud to possess it.

The size of this book is 9x12 inches, same size as SHORT WAVE CRAFT magazine. It is printed on a good grade of paper, and has a heavy durable cover.

Mail this Coupon Today!

SHORT WAVE CRAFT
96-98 Park Place,
New York, N. Y.

Gentlemen: I enclose herewith 25c for which send to me prepaid. Immediately upon publication a copy of your new book OFFICIAL SHORT WAVE LEAGUE LOG AND CALL BOOK. (Send money order, check, cash or new U. S. Stamps. Register letter if it contains stamps or currency.)

Name.....

Address.....

City.....State.....

SW-1033

FOR SALE ON ALL PRINCIPAL NEWSSTANDS

PRICE

25c

As only a limited quantity was printed for the first issue, it is possible that your newsdealer sold out his supply.

Should you not be able to secure a copy at your newsstand, use the handy coupon.

SHORT WAVE CRAFT

96-98 PARK PLACE

NEW YORK, N. Y.

The Propagation of 3 to 8 Meter Waves

(Continued from page 373)

tance between the transmitter and receiver and that it has an additional attenuation, equal to $e^{-\infty/\lambda}$.

Reflection Effects

In the case of ultra-short waves the phenomenon of reflection is very common, both inside and outside of buildings. The extent to which diffraction and refraction take place should not be prophesied until more extensive data are available. The reception of five-meter signals at distances of 200 and 300 miles at points far below the line-of-sight, and reception behind hills, indicates that diffractions or refraction or both do exist to a very noticeable degree.

Returning to the subject of simple reflection, it was found that interference patterns invariably exist except where the terrain is open and flat. They are frequently caused by reflections from relatively near-by objects. In many cases they are so severe that excellent signals will be received in "live spots" whereas several feet away from these spots no signal can be heard. The general occurrence and severity of interference patterns on these wavelengths is of great importance in the design of antennas for ultra-short-wave broadcast reception. The question of receiver antenna design is not discussed in this paper. The existence of an interference pattern infers reception over two or more paths of propagation. If the paths of propagation are sufficiently different in length, a distortion phenomenon similar to the distortion in ordinary selective fading will take place. In the case of television, where very high modulation frequencies are used when transmitting pictures of fine detail, the difference of path length that will produce distortion is surprisingly small.

Reflections within the rooms of a residence were investigated by Messrs. Koch and Grundman of the research division in connection with the design of television receiving antennas. This paper does not deal with reception, nevertheless the field strength contour lines obtained on the first floor of the residence are reproduced in Fig. 9 to indicate the general intensity of reflections. The data were obtained by using a small transmitter placed one hundred feet from the residence, and a small calibrated receiver. Polarization was vertical. Fig. 9 shows contours for transmitted frequency of fifty megacycles.

Lightning struck the Empire State antennas several times when they were in operation without effect except to produce a loud click in the output signal. Ordinary atmospheric static was not heard on ultra-short wavelengths, even during the middle of the summer, except on several occasions when lightning struck within one mile of the receiving point. Then several clicks were audible.

All ultra-short-wave observations made at distances within the line-of-sight have shown no indications of fading.

Observations made on the first floors of residences in the suburban area, and on the higher floors of apartment houses and hotels in the city areas, indicate that fluctuations are much less severe when the receiving point is not near traffic. Fluctuations of the severity discussed will not have to be contended with in the majority of ultra-short-wave broadcast receiver installations.

Long-Distance Reception

To find the maximum range of the transmitters, observations were made at several distant points including Mt. Greylock and Mt. Washington. The high sensitivity receiver previously described was used for these tests, with a half-wave antenna fifteen or twenty feet above ground. Both the sixty-one- and forty-four-megacycles transmissions were observed, the observations usually being carried on alternately on each frequency for periods of ten to fifteen minutes.

The top of Mt. Greylock is 3505 feet above sea level, 140 miles from New York, and 5000 feet below line-of-sight to the Empire State antennas. Both signals were received at Mt. Greylock, with large but gradual variations in signal strength. During the eclipse of August 31, 1932, nothing unusual was observed.

The top of Mt. Washington is 6290 feet above sea level, 284 miles from New York, and 37,600 feet below line-of-sight to the Empire State antennas. On September 3 both signals were strong. Thereafter, on September 6, 7, and 8, the forty-four-megacycle signal was usually audible but seldom delivered more than one microvolt to the receiver terminals. The sixty-one-megacycle signal was inaudible most of the time. Its apparent inferiority may be accounted for by the use of program modulation, which was not as favorable for threshold hearing as the 1000-cycle tone used on forty-four megacycles.

Various types of fading phenomena presented themselves. At times the signal was nearly constant and at other times faded at various rates up to ten or twenty cycles per second. The peak amplitudes varied greatly. Sometimes the signal would burst through sharply for a short period, then be inaudible for a few seconds, then rapidly burst through again at different amplitudes. At other times marked fading at several cycles per second would be heard, the signal frequently dying out after five or six peaks. At times 2000 cycles, the second harmonic of the modulation frequency, was distinctly heard. On September 8, at 9:35 a. m., the signal, after being very weak whenever observed during the previous two days, suddenly started to increase. After a series of fading cycles, with each peak higher than the previous one, the signal delivered over ten microvolts to the receiver terminals. After reaching this peak the signal died off in a similar manner, the entire process lasting about fifteen seconds. During the peak of the cycle the signal varied from zero to its full value about three times per second. These types of ultra-short-wave fading differ from the fading experienced on higher wavelengths in that, instead of the signal varying between relatively fixed maxima and minima, it reaches momentarily an occasional maximum of great intensity.

Measurements were made at 200, 150, and 100 miles from New York at relatively low elevations. At 200 miles the signal was momentarily audible about every ten minutes or so. At 100 miles reception was almost identical to that on Mt. Washington, the same phenomena being noticed. This was north of New York. At Camden, eighty-five miles south of New York, the signal evidenced less severe fluctuations. An observation taken at sea 170 miles east of New York, using an antenna sixty feet above sea level, indicated little or no variation in signal strength. Therefore long-distance reception is not always accompanied by severe fluctuations of the signal.

The exact manner in which long-distance ultra-short-wave propagation takes place cannot be predicted from the insufficient data on hand. Three possibilities regarding the Mt. Washington reception seem highly improbable. The first is that local conditions around the receiver caused some of the variations. This is unlikely because conditions near the location were exceptionally constant due to the isolation of the location. Also identical results were obtained at several points of reception.

The second possibility is that the variations were caused by a single ray varying in amplitude. This may have occurred when the signal varied irregularly. But at times periodic fading was observed, and it is improbable that a single ray would

(Continued on page 377)

QUALITY APPARATUS FOR Short Waves

GEN WIN SHORT WAVE COIL KIT



These coils are considered the finest made. Each coil is precision wound on a different colored bakelite form for quick identification of wave lengths. Used and highly recommended by all short wave experts. Range 116 to 225 meters, using a .00011 or .00015 mfd. condenser. Recommended for the following sets: "The Globe Trotter," "The Overseas," "The Doerle 12,500 Mile Two Tube Receiver and Doerle Three Tube Signal Gripper," "The Magdayne," "4 Coil Enamel Wire" and "4 Coil Litz Wire".

| | | | |
|-------------------------------------|--------|-----|--------|
| Kit | \$1.50 | Kit | \$2.25 |
| Broadcast Coil, (200 to 550 meters) | | | 55c |

POLICE AND SHORT WAVE ADAPTER

Convert your broadcast set into a shortwave set tuning from 80 to 200 meters.

Get exciting police alarms from stations thousands of miles away. Airplane communications while in flight. A two tube phone and international coil communication. The biggest thrill and fun for little money. Installed in Jiffy. Plug directly into the detector tube socket. Simply the detector tube in your set, or if uncertain as to detector tube, also make and model number of set when ordering.

| | |
|------------------------------------|--------|
| No. 200—for '27, '37 | \$1.39 |
| and '56 Det. tube | |
| No. 201—for '24, '35, and '56 Det. | \$1.39 |
| tube | |

ALL-WAVE COIL KIT

Range 25 to 550 Meters. Contains precision wound tuner and R. F. coil to be having in mind secondaries which permits you to enjoy both SHORT WAVE and H. R. O. A. D. C. ST. P. G. GRAMS. If you own an An-larson or any other three circuit tuner receiver, you can easily convert the set into an all wave receiver, by replacing the coils, with these new ALL-WAVE coils. Coils may be had for use with either .00005 or .0005 Mfd. condenser. Specify which when ordering. Wiring diagram included free with coils. Separately 10c.

| | |
|---------------------------------|-----|
| All Wave Tuner (as illustrated) | 90c |
| All Wave R. F. Coil | 75c |

GENERAL WINDING COMPANY
254 W. 31 St. NEW YORK, N. Y.

YOU GET THERE!

with RCA Institutes radio training



No matter what you want to learn in practical Radio... whether you desire elementary or advanced knowledge RCA Institutes is fully prepared to give you the training.

RESIDENT SCHOOLS NEW YORK AND CHICAGO
Illustrated Catalog on Request
EXTENSION COURSES FOR HOME STUDY under convenient "no obligation" plan.
R.C.A. INSTITUTES, INC. Dept. SW-10
75 Varick Street, New York
1154 Merchandise Mart, Chicago

FORDSON presents RADIO'S BIG VALUE

Here is our challenge to the industry—the 6-tube Goldenrod Super. Its value has never been duplicated in household radio! Automatic volume control... full range tone control... dynamic speaker... new 55 and Class A type 24 tubes... a full-size radio in every feature of construction and performance. Among hundreds of enthusiastic letters from users, A. Adkins W. Va. writes: "Overperformed 12-tube set in every way. I get one pipe... this guaranteed set complete with beautifully hand-installed cabinets and 6-genuine Raytheon or DuPont tubes—others wonder how we can do it! This same set available for battery operation, using the new Air-Cell battery!"

30 DAYS FREE TRIAL

NOTE: While Fordson now indicates that to equalize leaving the quality field in low price, our prices, too, are bound to compare favorably with our competitors. We urge you to buy now while our rock-bottom prices prevail!

6-Tube Chassis \$9.95 6-TUBE FORDSON ALL-ELECTRIC CAR RADIO and Dynamic Speaker

Acknowledged one of the finest engineered auto radios on the market. One-piece construction. Installed in 30 minutes. Only 2 wires to connect. At a sensational price! **Write!**

Send for literature with full descriptions of Fordson line of household, electric and battery sets and car radios at Fordson a low price!

FREE SPECIAL AGENTS PROPOSITION!
Extra Profit, free advertising literature with your name attractive resale prices that get the business! Investigate.

Fordson Radio Manufacturing Co.
11703 Livernois Ave., Detroit, Mich.
Send me descriptive literature FREE.

Name: _____
Address: _____
City: _____ State: _____

vary uniformly at a rate of several cycles per second. Furthermore, the reception of a 2000-cycle tone intimates the existence of multipath propagation.

The third possibility is that the variations were caused by interference between two ground rays or between a ground ray and some other ray. A ground ray would be highly improbable at Mt. Washington due to the great attenuation. Furthermore, since all signal variations heard were relatively rapid, cancellation of the steady ground wave should be for only brief periods, whereas actually the signal was often inaudible for hours. The presence of a ground wave of the type observed for higher wavelengths, therefore, seems unlikely.

Whether the signals heard were diffracted or refracted or propagated in some unknown manner cannot be predicted as yet. It is possible that refraction due to air layers of different density, as suggested by J. R. Jenoust is a cause of the

fluctuations observed. If such fluctuations are ever controlled or eliminated, ultra-short wavelengths may prove useful for services extending to several hundred miles.

The long-distance airplane observations indicated little or no absorption of the wave when the receiving point is sufficiently high that the wave does not pass near the ground. Thus a five-meter transmitter with antenna 800 feet above ground will produce approximately the same field strength at 100 miles at high altitude as at fifteen miles on the ground.

It is assured that for the transmission of television broadcasting, sound broadcasting, facsimile broadcasting, aircraft communications, police communications and certain other types of public and private communications, ultra-short waves will prove definitely useful.—(Excerpt from paper by L. F. Jones; Proceedings of the Institute of Radio Engineers, Vol. 21, No. 1.)

The "Rex" Portable Superhet

(Continued from page 371)

A very compact magnetic speaker is used and the impedance of the speaker has been made very high, so as to match the output impedance of the pentode tube.

Volume is controlled by means of the potentiometer shunted across the "C" battery and as the intermediate frequency tube is of the variable- μ type, satisfactory control of the volume level can be obtained with a minimum of cross-talk.

Simplicity of circuit layout with due regard to operational results has resulted in a receiver that should meet with the approval of every set builder.

Wiring

Run all leads as short as possible. Do not try to cable the leads, as this will result in instability and loss in signal strength in most cases.

Use a clean hot soldering iron and make all connections mechanically tight before applying the solder. Clean all soldered connections with alcohol to prevent corrosion.

Operation

After the set has been checked as to the correctness of the wiring, it is then time to make the first operational test. It is wise to connect the set to the batteries before placing the units in the case, so that any necessary changes can be made if desired.

Connect the batteries and the loud speaker to the set. Place the tubes in their respective sockets and you are ready to "go ahead."

Connect the antenna and the ground to the flexible wires brought through a hole in the panel for that purpose, and plug in a set of coils, one in the oscillator coil socket and the other in the detector socket.

Start with the red coils as these cover the 40-80-meter bands and tune slowly with the two tank condensers. Have the volume control on full.

Keep the filament potential at 2 volts. As soon as a signal is tuned in, note that the oscillator tuning control setting will be different than that of the detector tuning condenser setting.

It will be necessary to remove two turns from the large winding of the oscillator grid coil so that the two tank condensers will "track" along together.

On the 20-40 meter coil it will be necessary to remove one turn, and on the 10-20 meter coil no turns will have to be removed.

As the frequency of the received signal becomes less, more turns will have to be removed from the oscillator coils so that the tank condensers will "track." Proceed carefully from this point with the 80-200 meter coil and the broadcast coils. Take off a few turns at a time until they track. Do not remove turns from the detector grid coils under any circumstance!

It will be noted that the coupling between the oscillator and the first detector is made through a small capacity; this condenser is made by winding four turns of No. 18 push-back wire as shown. Adjust this condenser for the smoothest operation on all frequency bands and leave it alone.

Conclusion

A receiving set of this kind has a very distinct place in the short-wave field for many reasons, most of which will be apparent to the reader of this article. The results that can and have been obtained with this receiver insure the builder that this circuit will be incorporated in receivers of the coming year, as it is the authors' definite idea that the compact 5-tube short-wave "superhet" will supplant the one radio frequency, detector and two audio stage receiver that has been so popular to date.

Alden Plug-In Coil Data

| Meters Wave-length | Grid coil turns | Tickler turns | Distance between 2 coils |
|--------------------|---|--------------------------------------|--------------------------|
| 200-80 | 52 T. No. 28 En. Wound 32 T. per inch | 19 T. No. 30 En. Close wound (CW) | 1/8" |
| 80-40 | 23 T. No. 28 En. Wound 16 T. per inch | 11 T. No. 30 En. C. W. | 3/8" |
| 40-20 | 11 T. No. 28 En. 3-32" between turns | 9 T. No. 30 En. C. W. | 1/2" |
| 20-10 | 5 T. No. 28 En. 3-16" between turns | 7 T. No. 30 En. C. W. | 1/2" |

Coll form—2 1/4" long by 1 1/4" dia. 4-pin base.

Parts List

"REX" Portable Superhet

- 2 sets of Alden plug-in SW 2-Winding coils (L, L1)
- 1 Hammarlund 35 mmf. dual cond. (C1)
- 2 Hammarlund 100 mmf. cond. (C)
- 2 Hammarlund 465 kc. I.F. trans. (IFT)
- 3 Acratest .0001 mf. mica condensers (C2)
- 4 Tubular cond. .01 mf. (C3)
- 1 Acratest .00025 mica cond. (C4)
- 1 Tubular cond. .015 mf. (C5)
- 1 Acratest .002 mf. mica cond. (C6)
- 2 32 type wafer sockets, Eby (Na-ald)
- 1 30 type wafer sockets, Eby (Na-ald)
- 1 33 type wafer sockets, Eby (Na-ald)
- 1 34 type wafer sockets, Eby (Na-ald)
- 2 plain 4 prong wafer sockets, Eby (Na-ald)
- 1 Acratest 3 meg. 1/2 watt resistor (R1)
- 2 Acratest 1 meg. 1/2 watt resistor (R5, R6)
- 2 Acratest .5 meg. 1/2 watt resistor (R2, R3)
- 1 "dual" circuit-closing toggle switch (S)
- 1 Acratest 6 ohm rheostat (R7)
- 1 Acratest potentiometer, 50,000 ohm (R4)
- 1 Acratest 800 henry choke (A. F. C.)
- 1 5" diameter magnetic loud speaker; 7000 ohms impedance
- 1 carrying case
- 2 Special panels: Aluminum (drilled as per drawings)
- 1 special hardware kit
- 1 National 3" vernier dial
- 4 1" small black knobs
- Wire, soldering lugs, etc.

ENJOY the THRILL

Learn at Home to be a Fast and Capable Operator with the Candler Scientific System of Radio Telegraphy

FREE short wave press schedules. Learn to copy "px" from Candler Trained Operators, sending out of principal press stations. Amazing results in short time with Candler Training. FREE ADVICE if you are "stuck." Write Candler at once. No obligation. Junior course for beginners. Advanced course for operators with speed of 10 wpm or more who want to get into 30 to 45 wpm and copy behind. Only Typing course for Radio operators. Save time and money. Send for FREE BOOK now.

Jean Hudson, world's youngest licensed operator. 9 year old Candler student, wins 20 wpm class in A. R. R. L. speed contests.

Walter H. Candler, President

Candler System Co.

6343 S. Kedzie Ave.

Dept. 27

Chicago



SPAIN OR AFRICA NO TRACE OF HUM

In Supertone A-C Short-Wave Set

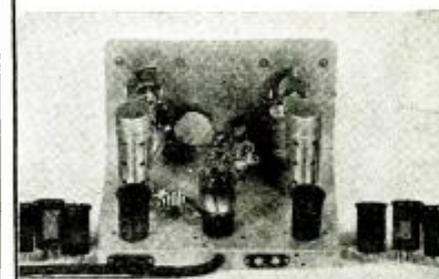

A Dream Come True—Big Results on Short Waves at Very Little Cost!

Complete kit of parts for building both the receiver and the separate power supply, contains everything except tubes and set cabinet. The speaker \$19.25 is included

Five tubes (one 58, one 57, one 56, one 2A5, one 80) at \$3.75 extra.

The wired and tested model consists of the kit built up at our precision laboratory by expert engineers. The price, less tubes, but including \$23.50 speaker

The receiver proper, less the power supply, less speaker, and less tubes. This outfit can be worked with a filament transformer and a B eliminator, and the price of the wired receiver is \$12.00

SUPERTONE PRODUCTS CORP.
35 Hooper St., S. W., Brooklyn, N. Y.

•DID YOU GET YOUR COPY?



Thousands of amateur radio items, at the lowest prices, are contained in this FREE Big Book.

Contains articles by McMurdo Silver, Arthur H. Lynch, I. A. Mitchell, Henry McArthur, and many others.

AMERICAN SALES CO.

Wholesale Radio Distributors

44 W. 18th St., N. Y., N. Y.

The Oldest Amateur Supply House, Est. 1919

FREE

This Regular 50c Manual

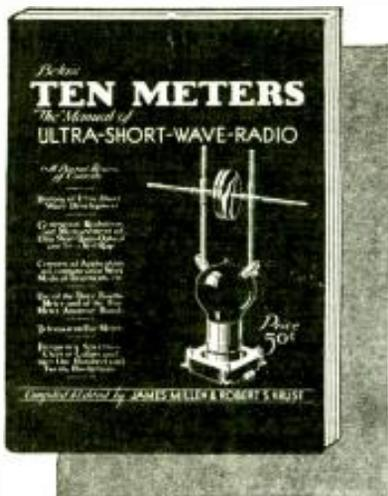

Here is your chance to read up on ultra short wave radio! "Below Ten Meters," is by far the best compilation of technical data on the very short waves, which are now becoming increasingly popular and important. There are 88 pages, thick full of practical "how-to" diagrams and photos—all clearly presented in understandable form. Compiled and edited by those famous short wave experts, James Millen and Robert S. Kruse.

● Given FREE ●

This book is given to you absolutely free with a One Year Subscription to SHORT WAVE CRAFT. Twelve big issues, which bring you an entire year's information on the latest developments in short wave radio. Your first copy of SHORT WAVE CRAFT will be sent promptly . . . the Short Wave Manual will reach you in a day or two.

Send \$2.50 in check or money order for a year's subscription to SHORT WAVE CRAFT. Register letter if it contains stamps or currency. (Canadian and foreign 50c extra.)

SHORT WAVE CRAFT

96-98 Park Place New York, N. Y.

Midget 5 in 1 Slide Rule



Metal 4" Dia.
Price \$1.50
Case 50c extra

- 1.23² = √50.41 = ?
- 1.24³ = ?
- Tan 80°5' = ?
- Cot 79 1/2° = ?
- 4 1/2 × 1/8 = ?
- Log 56.25 = ?
- 6% of 145.9 = ?
- 5.16 - 4 + 1.78 = ?

Solve easily all these and dozens of other mathematical problems without pencil and paper—by means of the Midget Slide Rule. This rule solves any problem in multiplication, division, addition, subtraction, and proportion. It also gives roots and powers of numbers. The "Trig" scales give the sines, cosines, tangents and cotangents of all angles, also logs of numbers. Adds and subtracts fractions. Approved by colleges.

Dataprint Co., Box 322, Ramsey, N. J.

FREE RADIO CATALOG

1934 RADIO CATALOG

Write for our new catalog—the most complete line of latest radio sets, service men's supplies, replacement parts at lowest wholesale prices.

ALLIED RADIO CORP.

837 W. Jackson Blvd. CHICAGO

10¢ A DAY BUYS A NEW REMINGTON PORTABLE TYPEWRITER

Special 7-Day Free Trial Offer

Think of it! You can buy a new standard Remington Portable Typewriter for but 10c a day. Standard keyboard. Small and capital letters. Beautiful finish. Carrying case included free. Exceptional money-making opportunities. Write today. Say: Please tell me how I can get a new Remington Portable typewriter on your special 7-day free trial offer for but 10c a day. Remington Rand Inc., Dept. SW-1 Buffalo, N. Y.



Letters from S-W Fans

(Continued from page 348)

"Amlie Dixer" Makes Good

Editor, SHORT WAVE CRAFT:
I am writing you in regards to reception I have had on the Amlie DXer the past four months. To date I have logged these stations and the following are foreign stations:

- | | | |
|----------------|----------------|-------------|
| KKP—18.71 M. | Pontoise, | YVQ—22.48 |
| HJB—20.06 M. | France—1968 | Y9JR—25.60 |
| DJD—25.51 M. | RXC—20.69 | I2RO—25.40 |
| EAQ—30.40 M. | PTE—16.44 | GSA—49.60 |
| YVIBC—49.10 M. | GSC—31.30 | GCW—30.60 |
| PRADO—45.31 M. | GBC—34.56 | HBP 38.47 |
| HBL—31.30 M. | YK2ME—31.28 | VE9DR—49.46 |
| NDA—51.00 M. | DIQ—29.26 | DJC—49.83 |
| CTIAA—31.25 M. | VK3ME—31.55 | GSB—31.55 |
| VE9GW—49.22 M. | RABAT—32.26 | LSX—28.98 |
| GSE—25.28 M. | HJ3ABD—40.50 | DJA—31.38 |
| | Puntoise—25.60 | |

These are the S.W. stations in U. S. and Bermuda that I have logged to date:

- | | | |
|-------------|-------------|-------------|
| W8XK—1972 | W8XK—25.25 | W1XAL—25.42 |
| W1XAZ—31.36 | W2XAF—31.48 | W9P—49.18 |
| W8XK—48.86 | W1XAL—49.67 | WNC—19.91 |
| KWT—18.54 | WOO—35.02 | W3XAL—4918 |
| W2XE—49.02 | W3XAL—49.50 | W8XAL—49.50 |
| YRT—29.80 | WEF—31.60 | WOA—44.41 |
| WNB—51.09 | VRT—59.42 | WEA—28.28 |

and numerous airport, police, ships and amateur stations which I did not log.

ARTHUR MITCHELL,
339 S. Court St.,
Steuenville, Ohio.

(Great work, Arthur, and more power to you. We have heard some very fine compliments concerning the "Amlie DXer," which was described in the May, 1932, issue of SHORT WAVE CRAFT. It is indeed surprising what results can be obtained with a little careful tuning, when using a 3-tube receiver of this type. It is pretty hard to beat a good receiver with this line-up of tubes.—Editor.)

4,000 MILES ON THE "MEGADYNE"!

Editor, SHORT WAVE CRAFT:
I have just finished building the "Short Wave Megadyne." I have seen several reports of this set from builders in U. S. A. but none from anybody from any foreign country, specially like mine, so unfavorable for radio reception. The "Megadyne" works wonderful: the very first day I tried it I heard FYA from France, EAQ from Spain, HKA and HKO from Columbia and the American stations W2XAF, W3XAL, W8XK and W8XAL. Every station comes in fine with the head phones.

Well, I hope you did like to hear something about your "Megadyne" listening in stations about 4000 miles away.

G. V. DEL CASTILLO,
Casilla 63,
Chiclayo, Peru.

(Glad to hear from you, GVD, and coming all the way from Peru too. We do not receive as many letters from our numerous readers in foreign countries as we would like, and we trust that the publication of your letter will open the way to our many friends in foreign climes. We are glad to know that you found the "Megadyne" such a fine short-wave receiver. We have had some very excellent reports on the Megadyne and its "DX" qualities, but yours is one of the best we have had yet.—Editor.)

Wants Q.S.L. Swappers' Column

Editor, SHORT WAVE CRAFT:
I wonder if you could put in your SHORT WAVE CRAFT magazine, a section called "QSL card swappers" or "QRA's of fellows who would like to swap." In New Zealand I am told by a "Pen Pal" from there, 90% of the fellows are collectors of QSL's and want them from Americans. But they don't know who to write to for them, so I thought your magazine could help them—how about it, Mr Editor? I will send them any QRA's if the fellows will let me have theirs. Would appreciate it a lot if you will say something about it in the next issue of SHORT WAVE CRAFT. I don't miss a copy—it sure is a swell magazine.

JAMES B. ALEXANDER, Jr.
5637 Belmar Terrace,
Phila., Pa.

(Thanks for them kind words, James, and we are glad to publish your letter so that other readers can write to you. We fully believe from past experience that if the fellows in New Zealand and other far parts of the world write to you boys, whose names and addresses appear in the columns of SHORT WAVE CRAFT every month, especially to those whose names appear in our "Swappers" list, that they will surely hear from them.—Editor.)

Wants Transmitter Dope

Editor, SHORT WAVE CRAFT:
I have been reading SHORT WAVE CRAFT for about two years and I find that there is one thing lacking. Your magazine is excellent for receivers, but you seldom have anything about monitors and transmitters on 40 meters. I have built the "Globe Trotter" and receive a lot of "DX" on it. Some of the stations are YVQ, FYA, DOA, GBC, I2RO, EAQ, LSA, LSN, KKZ.
ALEX SHADAY,
2826 N. Taney St.,
Phila., Pa.

(We are sure that you will be agreeably surprised, Alex, as we have just started a new series on Amateur Transmitters—How to Build, Install, and Operate Them, in the September issue. Along with the new series on transmitters we also published the first article in the September number describing how to build a "monitor" and in the current number, the method of calibrating the monitor is explained. We have received many letters praising the "Globe Trotter" and we hope to hear again from you right soon.—Editor.)

A Progressive Club

Editor, SHORT WAVE CRAFT:
We have a club here in a suburb of South Bend known as the Ardmore Radio Club. The purpose of this club is to help "would-be-hams" get their exam. Every Wednesday morning at 11 A. M., D.S.T., Mr. Boch, our president, gives us code practice over his station W9AMI. He operates on the 80 meter band, the meetings are held every other Friday at 7:00 P.M. Anybody interested in this club please write or see me personally; my address is given below. There is no age limit to this club, so the members can be young or old. The officers are: Mr. Boch, President; Richard Davis, Vice President; Arthur O'Neil, Secretary; and William Davis, Treasurer.

We all buy SHORT WAVE CRAFT because it is a good magazine for beginners or hams.

ARTHUR O'NEIL, Sec.,
% Lawrence Anderson,
R.R. 3, Box 249, Ardmore, Ind.

("Fine Business," Arthur, and what this country needs—besides the much heralded 5-cent cigar that someone said we needed so badly—is some more of this fine spirit of cooperation on the part of licensed hams who will provide an half-hour or so of "code practice" at periodic intervals. Undoubtedly many more public-spirited ham station owners would offer such code practice service if they ever happened to think about it real seriously for a moment, as it is certainly a slow and uncertain process for the average code beginner, when he tries to speed up his knowledge of the dots and dashes by listening either to poor transmission, or else to such high speed signals that he gets but little if anything out of it.—Editor.)

He Improved "Doerle"

Editor, SHORT WAVE CRAFT:
I receive your publication regularly and thought I would tell you what I think of it. Well, I only built one set from all that appeared in your magazine. Yes, it was the "Doerle," but I added another audio and band-spread and have heard all continents and used it as a "station receiver" for seven months and it works "F.B." (Fine business). I noted where you asked for photos of "ham" stations; have not had

YOU SAID IT!

1 WINDS LIKE A WATCH

2 VISIBLE INK SUPPLY

Ask your dealer to show you a Nozac (no sack). Demand both 1 and 2 in the fountain pen you buy. Compare the Nozac with any other sackless pen. It alone provides quick, easy filling by positive mechanical action and at a glance reveals the ink supply. \$5.00 and more. Other Conklins \$2.75, \$3.50 and more. Pencils \$1.00 and up.

The Conklin Pen Co.
Chicago Toledo San Francisco

*Proved by over 2 years of general public use.

Conklin NOZAC
REG. U. S. PAT. OFF.
SATISFACTION GUARANTEED

Here It Is!

The finest and most ingenious STATION FINDER and RADIO MAP of the World

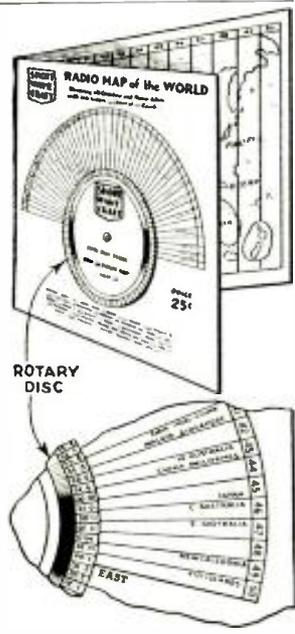

Here is a device that no radio man should do without. It lends that professional dignity to your den. It instantly shows you the exact time in any foreign country.

Professional short wave listeners are never without this station finder because they do not twiddle the dial needlessly in trying to fish for stations which may not be on the air due to time difference.

This handy device is printed on heavy yellow board; on the front there is the automatic time converter, which rotates; you can set it for any time of the day in fifty different zones in the world. On the inside are illustrated the fifty zones showing the principal countries of the world. All the important cities are shown, and inasmuch as they are all zoned, the exact time can be converted within a few seconds.

The size of the station finder and radio map of the world is 11x22. The price of this handy device is 25c prepaid.

Warning: It is sold only to members of the Short Wave League. Outsiders cannot buy it.

We refer you to page 378 for order blank. Take advantage of this opportunity at once, and get rid of your present annoyance in calculating the time for the different countries.

SHORT WAVE LEAGUE
98 Park Place New York, N. Y.

any taken yet, but when I do will send one along.

Thanking you for the Doerle circuit and "F.B." publication.

HARRY T. MacLELLAN, VE2GG,
5881 Esplanade Ave.,
Montreal, P. Q. Can.

(This is the sort of letter that interests us greatly, Harry, and we are sure that there must be many improvements which the thousands of readers of SHORT WAVE CRAFT magazine made on the many receivers and other sets which we describe from month to month, but about which we never hear a "peep.") We hope that many of our readers will sit down to their trusty typewriter and tell us about some of these additions that they have made to sets described in SHORT WAVE CRAFT and which they have successfully built. All articles accepted and published will be paid for at regular space rates and so the reader who is finally moved to write in detail about his latest "rig" will find it quite worth his while. Just as a hint, we might suggest that every article, whether large or small is made twice as attractive from the publication standpoint when it is accompanied by one or several good "clear" photographs! If you only have a small camera and the photos are really clear and sharp, we can have enlargements made from them, or possibly you can do this yourself. If you will look through the recent numbers of this magazine you will find that the best looking articles are those that have attractive photographs. Remember that the reader wants to see that the apparatus has actually been built, and it has far more charm than merely a line diagram; also don't forget some good photos of those "ham" stations, and photos of "receiving stations" only are also very welcome.—Editor.)

Likes Our "Latest Tube" Circuits!
Editor, SHORT WAVE CRAFT:

I am a service man who doesn't go so much for short wave experimenting, because I have all I can do to keep up with the later improvements of the broadcast sets, but I would like to tell the editors, authors and staff that I always find time to secure and read SHORT WAVE CRAFT, and have on file every copy for the last two years. What I like mainly about SHORT WAVE CRAFT is that the staff puts the dope and circuits of the latest tubes in the magazine as soon as the tubes come out. I always glance through the magazine when I first buy it, then I turn to the Question Box page and always find it quite interesting; then I read the rest of the magazine as soon as I can find time. I built the Denton "2-Tube All-Wave" receiver when it came out in the September issue, (1932), and have added a stage of R.F. to it, using a 58 and also an audio stage, using a 2A5 and it sure has got a wallop! It's the best little job, for a shop-built job, that I have ever seen. Will be glad to give information concerning it to those who wish, if they will write me, enclosing a stamped and addressed envelope.

JAMES B. MATHEWS,
1018 East Pierce St.,
Phoenix, Arizona.

(We are glad, James, that you like the dope on the latest tubes and circuits in which to use them, as published right along in SHORT WAVE CRAFT, and we hope to continue meriting your good-will and confidence in the coming months. We have a lot of fine things in store for our readers, including articles on both small and large receivers, transmitters, etc., and as we have done in the past we, are endeavoring in every issue to present a goodly variety of articles so that all classes of readers will be taken care of. We are glad to note that you found the DENTON 2-TUBE ALL WAVE RECEIVER to your liking and undoubtedly you will receive quite a "flock" of letters after this publication of your offer to give additional information on the operation and improvement of the "2-Tube All Waver." —Editor.)

NEXT ISSUE!
You can't Afford to Miss the New Receiver Circuits.

MAYO MICROPHONES
Have Stood the Test

After years of daily service MAYO microphones stand the test of hard use and abuse. Their scientific design, careful test and adjustment by experienced engineers insures lasting quality under any and all conditions. YOU WILL FIND THAT RESULTS ARE BETTER WITH MAYO MICROPHONES.

Mode "F"
\$5.00
NET TO THE TRADE



at your distributor or sent postpaid on receipt of remittance

Here is the biggest value ever offered in commercial type microphones. Large two button rugged constructed microphones designed for broadcasting, short wave work, public address systems, recording, etc. Has frequency response 30 to 5000 cycles, pure gold contacts throughout size 2 1/4 in. thick by 3 1/2 in. dia. Furnished either 100 or 200 ohms per button, weight 1 3/4 lbs. Polished chromium finish. A microphone that you will be proud to own.

Your distributor carries this microphone, if not, it will be sent postpaid on receipt of your remittance or C. O. D. plus charges. If you are not thoroughly satisfied return same within 5 days and we will make refund.

Microphone Repairs

The MAYO microphone repair dept. is part of our vast service. Our complete equipment and experienced engineers insures accurate repairs on any and all makes or types of microphones.

Repair Costs Are Low
Floating diaphragm.....from \$1.00 to \$2.50
Stretched diaphragm.....from \$3.00 to \$5.00
Others on request. Address all repairs to Dept. R 21.

CARBON—Special processed for repacking your own microphone, enough to repair two microphones—50c.

MAYO MICROPHONES
Maylux Mfg. Corp.

19 Park Place New York, N. Y.

SEND FOR FREE RADIO ACCESSORY CATALOG

WE WILL NOT BE UNDERSOLD!

COAST TO COAST RADIO CORPORATION
715 WEST 17th STREET
NEW YORK, N. Y.

Learn TELEVISION

LATHROP RAY

and other types Television at W9XAL. Thoro training qualifies for 1st class license. 95% grads passed federal exam to date. Practical experience on experimental visual station W9XAL. Medium and quasi-optic frequencies. Studios, stop skyscraper. Placement bureau.

FIRST NATIONAL TELEVISION,
3814 Power & Light Bldg., Kansas City, Mo.

See Page 362 for important book announcement.

an old timer says—

San Francisco, Calif.

Gentlemen:
 Allow me to congratulate you on Myron F. Eddy's "How to Become an Amateur Radio Operator." I have been a "ham" since 1909 and have worked up from the open crashing sparks of "Old Betsy's" and took sullenly to these new fangled gadgets and had to park "Betsy" in the junk heap under the eaves to go in for tubes. I'm too old now to dabble in the game very much but in my teaching a bunch of ether disturbing young squirts here—all Boy Scouts, I still get a certain "kick" out of it. I purchased nine copies for my gang and I suppose five or six others got them because they saw ours—had to send to Oakland for three additional copies. They're GREAT!

One of the "Old Men" of Radio
 Ex. Lieut. Al. A. Weber (Retired)
 1153 Capp St., San Francisco, Calif.



50c
 EACH

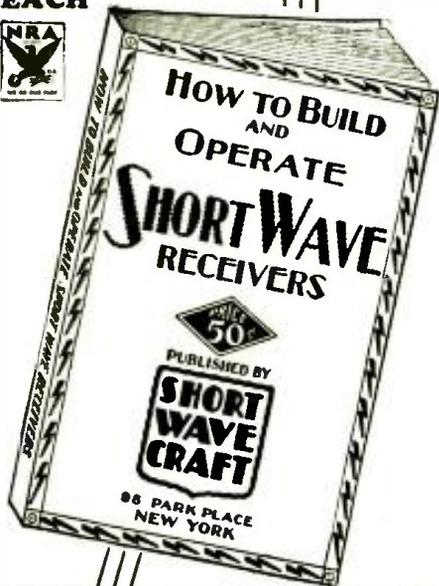

SHORT WAVE CRAFT
 96-98 SWC Park Place,
 New York, N. Y.

Gentlemen: I enclose herewith \$.....
 for which please send me, prepaid a copy
 of the book checked.

() HOW TO BUILD AND OPERATE
 SHORT WAVE RECEIVERS—50c
 () HOW TO BECOME AN AMATEUR
 RADIO OPERATOR—50c.

Send money order, check, cash or new
 U. S. stamps. Register letter if it con-
 tains stamps or currency.

Name

Address

City..... State.....

THERE is not a radio man in the field, experimenter, service man or dealer who will not want to read these two books. Right up to the minute with outstanding developments in short-wave radio—new methods and apparatus for quickly learning how to become a practical radio operator. Each book is authoritative, completely illustrated and not too highly technical. The text is easily and quickly grasped.

How to Become an Amateur Radio Operator
 We chose Lieut. Myron F. Eddy to write this book because his long years of experience in the amateur field have made him pre-eminent in this line. For many years he was instructor of radio telegraphy at the R.C.A. Institute. He is a member of the I.R.E. (Institute of Radio Engineers), also the Veteran Wireless Operators' Association.

If you intend to become a licensed code operator, if you wish to take up phone work eventually, if you wish to prepare yourself for this important subject—this is the book you must get.

Partial List of Contents

Ways of learning the code. A system of sending and receiving with necessary drill words is supplied so that you may work with approved methods. Concise, authoritative definitions of radio terms, units and laws, brief descriptions of commonly used pieces of radio equipment. This chapter gives the working terminology of the radio operator. Graphic symbols are used to indicate the various parts of radio circuits. General radio theory particularly as it applies to the beginner. The electron theory is briefly given, then waves—their creation, propagation and reception. Fundamental laws of electric circuits, particularly those used in radio are explained next and typical basic circuits are analyzed. Descriptions of modern receivers that are being used with success by amateurs. You are told how to build and operate these sets. Amateur transmitters. Diagrams with specifications are furnished so construction is made easy. Power equipment that may be used with transmitters and receivers, rectifiers, filters, batteries, etc. Regulations that apply to amateur operators. Appendix, which contains the International "Q" signals, conversion tables for reference purposes, etc.

How to Build and Operate Short Wave Receivers

is the best and most up-to-date book on the subject. It is edited and prepared by the editors of SHORT WAVE CRAFT, and contains a wealth of material on the building and operation, not only of typical short-wave receivers, but short-wave converters as well. Dozens of short-wave sets are found in this book, which contains hundreds of illustrations; actual photographs of sets built, hook-ups and diagrams galore.

The book comes with a heavy colored cover, and is printed throughout on first-class paper. No expense has been spared to make this the outstanding volume of its kind. The book measures 7½x10 inches.

This book is sold only at such a ridiculously low price because it is our aim to put this valuable work into the hands of every short-wave enthusiast.

We know that if you are at all interested in short waves you will not wish to do without this book. It is a most important and timely new radio publication.

Over 150 Illustrations in Each Book
72 Pages 7x10 Inches
Heavy Colored Covers
Not Sold on Newsstands

SHORT WAVE CRAFT
 96-98 Park Place, New York, N. Y.

Balancing the Transmitter Feeders

● THOUSANDS of amateur transmitters use the system shown in Fig. 1 for transferring power from the R.F. output stage to the antenna, namely the two-wire voltage feed method, series tuned. This system is no doubt most suitable and efficient for a majority of installations, but it capable of really bad performance if one important consideration is neglected—its balance!

By balance is meant that from point P on coupling coil L2, to points A and B at the antenna proper, there shall be an equality of electrical distance, capacity to the ground, and reactance in ohms, regardless of what tuning and measuring devices are needed as shown between lines XX and YY. If these conditions do not exist, there will not be the proper out-of-phase relationship between the voltages in the two feeder wires, upon which the system depends for its excellent operation. This lacking there will be radiation from the feeders themselves, (which reduces the value of the radiation from the antenna, also induces losses into absorbent materials in the proximity of the feeders) and losses at every spacer which cumulatively are serious, especially since in general construction these spacers are considered of secondary importance.

It is very easy to arrange the coil and lines to the antenna so that an electrical balance exists; it is with the tuning and metering apparatus that most amateurs thoughtlessly cause the radiating system to work at a handicap.

The Condensers

For best results it is necessary that the leads from the coil to the feeders be short and direct; and undue lengthening will result in stray capacity to the ground or to other parts of the circuit; both will tend toward unbalance, and the latter will be doubly bad because it can transfer power from the primary to one side of the system capacitatively, instead of inductively to the center as is ideally the case. This means that running leads from a coupling coil in the rear of a transmitter up to the panel, through condensers, then back to the feed lines can not be considered good practice, especially if the leads pass near other apparatus. The condensers should be of highest quality and identical, even to the location of the terminals. This last requisite may seem trivial, but with increasing frequency it is more important since current distributions (and therefore the losses) are dependent greatly on terminal location.

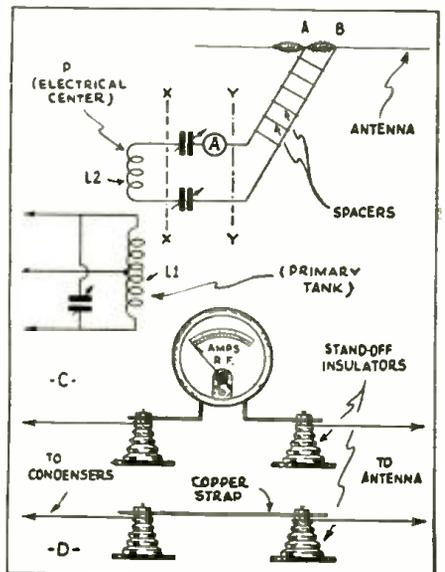

Valuable Pointers In Balancing Transmitting Feeders

Short Wave Craft



is not the sort of magazine that you read and then discard.

Readers keep their copies for years as a steady reference and thousands of letters attest to this.

It is now possible to save your copies and for this purpose we designed a splendid binder for you which holds twelve copies. It is made of heavy substantial material and is covered with black grain leatherette. The name of the magazine is stamped in gold on the cover.

An ingenious mechanical arrangement is provided which makes it possible to hold the copies flat when reading from the binder. SHORT WAVE CRAFT Binder as described, prepaid in the United States \$1.25

Canada and foreign countries 25c extra. We accept money order, check, stamps or cash.

SHORT WAVE CRAFT
98 Park Place New York, N. Y.

MILES REPRODUCER CO.

Oldest Manufacturers of complete sound amplifying equipment are now opening a new service for Hams, Experimenters and Servicemen

- 1—Overhauling any carbon mike non-stretch diaphragm types.....\$ 2.50
- Stretch diaphragm type..... 4.50
- 2—Converting any carbon mike into a condenser head..... 15.75

Send us your mike for prompt and accurate repair.

Quick Delivery

Catalog describing 300 types amplifiers, microphones, speakers, transformers on request.

MILES REPRODUCER CO.
244 W. 23rd St., Dept. A, New York City

ACME PHONES

for Short Wave Fans

4000 ohms D. C.



5 ounces Complete Weight

20,000 turns of magnet wire. The biggest value ever offered in lightweight head-phones. Extra sensitivity at low cost. Your favorite "Ham" store can supply you or write us for information.

Acme Specialty Company, Dept. W.
2000 Mendel Street Chicago, Ill.

NEW & MODERN AMPLIFYING EQUIPMENT

"Power with Quality"

DYNAMIC UNITS—HORNS—AMPLIFIERS—EXCITERS—HIGH FREQUENCY UNITS, etc.

New Catalog—Write for it TODAY

MACY ENGINEERING CO., 1450 39th St. Brooklyn, N.Y.
CHICAGO—1610 S. Mich. Ave. SAN FRANCISCO—7 Front St.
DALLAS—321 N. Bishop St. (Stocks at Dallas and Brooklyn)

Metering

The most prominent cause for unbalance is the careless habit of amateurs in metering only one side of the line, and to put this meter on the panel or somewhere else that makes for easy reading, with no thought of the unbalance caused. I have seen installations where as much as four feet was added to one side of the system in order that the meter might be panel-mounted! Metering should be done by direct connection in the lines, and short direct connections at that! Ideally there should be two identical meters, one in each line, but rarely does an amateur own these.

Many switching arrangements have been suggested for quickly transferring the current meter from one side of the line to the other. At best these are far from perfect; it is more trouble, but well worth it to actually move the meter from one line to the other when adjusting for balance. This may be handily accomplished by breaking each line for about two inches, (C and D, Figure 2), and terminating in binding posts. Between one set the meter should be connected, the other set can be connected by a copper strap. Swapping the meter from line to line is very quickly done in this manner. Adjustments should be made for equal MAXIMUM currents in the two sides of the line.—Fred Grimwood.

Wave-Trap for S-W Converter

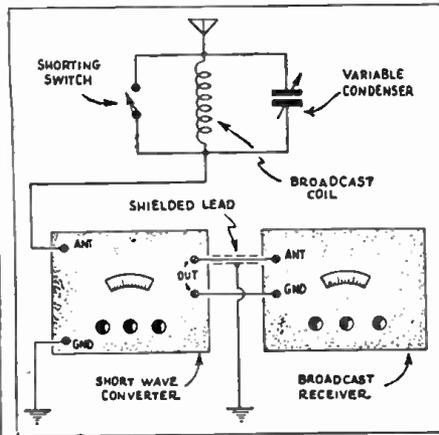

How To Use a Wave-Trap With a S-W Converter

● WHEN using a short-wave converter that requires the broadcast receiver dial to be set within the broadcast band, it is sometimes impossible to find a "quiet" spot. This is particularly true at night when there are so many stations on the air and the field strength of even the distant stations is high. The solution lies in the use of an old fashioned "wave-trap." This consists of a broadcast coil and a variable condenser, such as a T.R.F. transformer taken from an old three-dial neutrodyne, and connected in series with the antenna lead to the converter.

The procedure is to switch the antenna to the broadcast receiver, set the dial to the desired place, turn up the volume control, and tune the trap circuit to where any signal coming in disappears or is at a minimum. Return the antenna to the converter and everything will function as usual, minus the annoying interference from broadcast stations.

The wave-trap should be mounted on a small panel with a switch to short it out of the circuit when it is desired to receive broadcast stations, or it may be left in when tuning the broadcast band to eliminate interference from a powerful local station.

Be sure the lead from the converter output to the "Ant." post of the broadcast receiver is enclosed in a grounded shield.

—Joseph B. Farrell.

Sensational Buys in Amateur Parts!

We stock only NEW and GUARANTEED Short Wave Parts

| | |
|---|----------------------------|
| Preston well damped D.C. milliammeters: 0-15, 0-25, 0-100, 0-150, 0-200. Each | \$1.18 and 0-10.....\$.59 |
| Preston 0-5 D.C. M.A. meters | \$1.18 and 0-10.....\$.59 |
| Readrite latest model Set Analyzer—complete | \$14.70 |
| Readrite D.C. milliammeters: 0-15, 0-25, 0-50, 0-100, 0-150, 0-200, 0-300, 0-400. Each | .59 |
| Readrite Tuning Meters: 0-5, 0-7, 0-10, 0-12, 0-15 m.a. Each | .84 |
| Readrite Escutcheons for tuning meters | .18 |
| Readrite No. 1600 Set Analyzer, latest model out of stock | 29.40 |
| Jewel and Weston meters and Testing Instruments of all types in stock—write for prices | |
| Beale D'Arsonval type D.C. Milliammeters: 0-5, 0-10, 0-15, 0-25, 0-50, 0-1000 m.a. Each | 2.79 |
| Triplett D'Arsonval type D.C. Milliammeters: 0-5 to 0-1000 m.a. 3 1/2" finish models \$3.43. 2" finish models | 2.62 |
| Victor ABC Power Transformers for models R-32, R-52, RF-43, RF-75 | 1.79 |
| Allden S.W. Coils 1-10 to 20 to 200 meters: type 704SWS, Type 706SWS (6 prong) | 1.14 |
| Allden Coil Forms 4 and 5 prong types. Each 15c. 6-prong. | .18 |
| Allden Wire in stock, write for prices | |
| S.W. Plug-in Coil Forms, ribbed type: 4 and 5 prong. Each | .21 |
| 21. 6 prong type in stock | .30 |
| Metal monitor boxes of all sizes in stock | |

Write for FRFT bulletin now ready for mailing. Print your name and address clearly. 25¢ deposit with all orders. Balance C.O.D. Postage extra. Foreign orders accepted. Full remittance plus postage must accompany all foreign orders. Distributors of all NATIONALLY known radio parts.

MAURICE SCHWARTZ & SON
710-712 Broadway Schenectady, N. Y.

NEW ALDEN S. W. COILS

Precision wound coils with the convenient gripping ring for easy insertion and removal from socket.

Set of four precision wound short-wave coils—20 to 200 meters with .00014 mfd. condenser. 704SWS List Price \$2.00 set



NEW! 706SWS Set of four 6-prong wound coils with pri., sec. and tickler windings. 20-200 meters with 140 mmfd. condenser. Uses standard tube socket. 706SWS. List price. Set.....\$3.00

Set of two coils to cover 100 to 540 meters with .00014 mfd. condenser. 704SWS and 704SWO. List Price.....\$1.50

Genuine Makalot Coil Forms with color-coded easy-grip ring. 1 1/4 in. dia. x 2 in. winding space. Red, Yellow, Green or Blue. 704—4-pin coil form. List... 25c
705—5-pin coil form. List... 25c
706—6-pin coil form. List... 30c

Send for latest S. W. Sheets showing coils, sockets, plugs, etc. Send for new Analyzer Rewiring Dope Sheet and data on using new tubes in place of old types.

ALDEN PRODUCTS CO.
Dept. SW10 715 Center St. BROCKTON, MASS.

AMPLION



TYPE H. M. HAND MICROPHONE

Frequency range 7000 cycles. They contain no metal diaphragm, no carbon buttons, no metal levers or moving parts. Carbon hiss reduced to the minimum and they do not pack.

New Transverse Current Principle. Marvelous results are obtainable through this fine instrument. Write for Complete Technical Treatise on Microphones.

Special to "Hams" and "Experimenters" \$7.50 (List Price \$15.00)

Amplion Products Corp'n.
42 West 21st St., Dept. S.W. New York City

Now 108 PAGE free 1933 RADIO CATALOG

Replete with BARGAINS GALORE for DEALERS—SERVICEMEN—AMATEURS

Send for Your Copy TODAY!

TRY-MO RADIO CO. 85 CORTLAND ST. NEW YORK CITY
Dept. 5-10

CAMERA and COMPLETE OUTFIT 35¢

(Add 10c for postage and packing)

Take and make your own pictures

Brilliant View Finder
Good Quality Lens

Developing and Fixing Chemicals

4 Films
1 Package Printing Paper

1 Printing Frame
Everything necessary to turn out the finished picture.

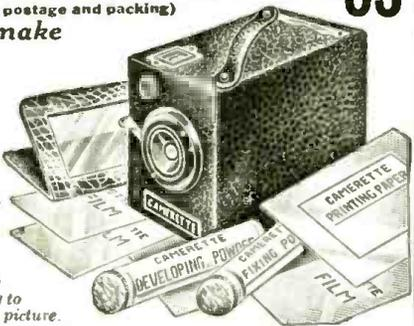

ALTHOUGH MARVELOUSLY CHEAP, it is quite efficient, and will take **SPLendid PICTURES**. Just the thing for beginners in photography. It takes pictures not quite 2 1/4 inches with clearness, sharpness and distinctness. Loads and unloads in daylight. Has a **VERY GOOD LENS**, **BRIGHT VIEW FINDER**, simple yet effective **SHUTTER**, time and instantaneous, leatherette handle. Comes complete with **4 FILMS**, 1 package of **PRINTING PAPER**, a neat little **PRINTING FRAME** with glass top, and **SUPPLY OF CHEMICALS** for developing, fixing and turning out the finished picture. Full printed instructions so plainly written that a child cannot fail to understand. Never before has such an inexpensive opportunity been offered of indulging in the fascinating art of photography. With this outfit you can take portraits of your friends, views of places of interest you may visit, and snapshots of curious events and quaint characters. **CAMERA and COMPLETE OUTFIT ONLY 35c with 10c extra for postage. EXTRA FILM 10c per package of 5 Films. EXTRA PRINTING PAPER 10c per package.**

BOYS! THROW YOUR VOICE

Into a trunk, under the bed or anywhere. Lots of fun fooling teacher, policeman or friends.

THE VENTRILO

a little instrument, fits in the mouth out of sight, used with above for Bird Calls, etc. Anyone can use it. Never falls. A 16-page course on Ventriloquism and the Ventrilo. All for 10c postpaid.

LUMINOUS PAINT

Make Your Watches, Clocks, Etc., Visible by Night

The world's latest discovery in the scientific world, **Hierbort's** previously unobtainable except at an exorbitant price, we have at last succeeded in producing this remarkable **LUMINOUS PAINT**, which, applied to the surface of any article, emits a **ray of white light**, rendering it perfectly visible in the dark. **THE DARKER THE NIGHT, THE MORE BRIGHT IT SHINES.** Quite simple to use. Anyone—you can do it. A little applied to the dial of your watch or clock will enable you to tell the time by night. You can coat the push buttons or switch plates of your electric lights, match boxes, and innumerable other articles; make your own luminous Cigarettes, Luminous Knives, etc. Being containing substances to coat several small articles. **Price 25c. Larger size 50c and \$1.00 postpaid.**

BIG ENTERTAINER

180 Jokes and Riddles. 34 Magic Tricks, 54 Parlor Games, 73 Toasts, 15 Tricks with Cards, 50 Money-making Secrets, 10 Funny Readings, 3 Monologues, 21 Puzzles and Problems, 5 Comic Recitations, Cut-outs for Checkers and Chess, Dominoes, Fox and Geese, 9 Men Morris, Spanish Prison Puzzle, Game of Anagrams, etc. All for 15c postpaid.

ONLY 10c Per Pair



Fighting Roosters

With very little practice you can make these miniature models of Game Roosters imitate in the most lifelike manner the evolutions of a **FIERCE COCK-FIGHT**. Endless amusement can be made, with real feathers. Pair 10c. 3 prs. 25c. postpaid.

GOOD LUCK RING

Very striking, quaint and unobscured. Silver, gold, or ornate brass designs. **Bring good luck.** Only 25c postpaid.

LEARN TO HYPNOTIZE

This book tells how. Explains all about Hypnotism, how to hypnotize, how to produce sleep, how to awaken a subject, how to hypnotize animals, hypnotism in diagnosis, etc. **ONLY 10c p.p.**

TELL YOUR OWN FUTURE

With the aid of this dream book and fortune-teller. The key to your future. Will you be lucky in love? Successful in business? Will you die in a ghastly manner? With dictionary of dreams with descriptions and correct interpretations, with lucky numbers, fortunate days, oracles, divination, palmistry, etc. **Price 10c p. pd.**

FORTUNE TELLING BY CARDS

64 page book tells how. Gives the meaning of each card and every card, how to deal and lay them out. Everything explained in simple language. **10c postpaid.**

PERFORMING SKELETON

A jointed figure of a skeleton 14 in. in height will dance to music and perform various gyrations and movements while the operator may be some distance from it. **Price 10c. 3 for 25c. pd.**

HOW TO PITCH

Book contains lessons by leading pitchers, written in simple language. 56 illustrations. **25c postpaid.**

125 CARD TRICKS and sleight of hand.

Contains all the latest and best card tricks as performed by celebrated magicians, with a course of card tricks used by professional gamblers. **Price 25c postpaid.**

5-MINUTE HARMONICA COURSE.

A new easy-teaching method. Teaches how to play, to use the tongue, tremolo, fully illustrated. **Price 15c postpaid.**

MONEY MAKING SECRETS.

Golden opportunities for everyone. 64 page copyrighted book chock full of money-making ideas, recipes, formulas, wrinkles, trade secrets, etc. Business that can be done with little or no capital at home in spare time. **10c postpaid.**

JOHNSON SMITH & CO.

Dept. 969, Racine, Wis.

A copy of our NEW CATALOG mailed on receipt of 10c, or the De Luxe Edition with cloth binding 25c. Bigger and better than ever. Only book of the newest novelties, puzzles, games, sporting goods, rubber stamps, unusual and interesting books, curiosities in seeds and plants, etc., unusual U. S. Postage Stamps, for all articles listed above. Check or money orders, stamps and Postal Notes accepted if 10% added for Exchange.

SOLAR TELESCOPE—\$1.25 NEARLY 3 FEET LONG



The new Excelsior Solar Telescope is a large and serviceable instrument, nicely made and accurately fitted. When extended it is almost three feet in length, and when closed measures not quite twelve inches in length. Telescopes of this size usually sell for many times this price, but by importing them direct from a large European manufacturer, we are enabled to offer them to our customers for **ONLY \$1.25 each**, at which price they ought to sell readily. The lenses are our own, the sides are brass bound, and the four sections are perfectly fitted. Here is your chance to obtain a Telescope for a nominal sum. It will be sent postpaid to any address upon receipt of \$1.25 in any convenient form. Postage stamps accepted if more convenient. **770 page Catalog of novelties, tricks, jokes, sporting goods, firearms, jewelry, novelties in seeds and plants, etc., 10c.**

BLANK CARTRIDGE PISTOL



Protection against Burglars, Tramps & Dogs
Prices 50c \$1.00
Shipped by Express only.
Well made and effective, modelled on latest type of Revolver; appearance alone is enough to scare a burglar. When loaded it may be as effective as a real revolver without danger to life. It takes standard 22 Cal. Blank Cartridges obtainable every where. **Price 50c. Superior quality, \$1.00. Blank Cartridges, 50c per 100. Mallet (Cowboy type) for Blank Cartridge Pistol, 50c. Shipped by Express only.**

LOOK 35¢ LOOK WONDERFUL INSTRUMENT



Greatest thing yet. Nine separate articles in one. Every body delighted with it. Odd, Curious and interesting. Lots of pleasure as well as very useful. It is a double Microscope for examining the wonders of nature. It is also an Opera Glass, a Stereoscope, a Burning Lens, a Reading Glass, a Telescope, a Compass, a pocket Mirror, and a Laryngoscope—for examining eyes, ear, nose and throat. It is worth all the cost to locate great—micro eyes. Folds flat and fits the pocket. **Only 35c or 3 for \$1.**

Electric Telegraph Set 15c

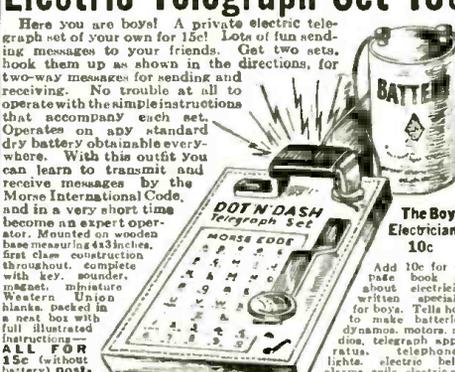

Here you are boys! A private electric telegraph set of your own for 15c! Lots of fun sending messages to your friends. Get two sets, hook them up as shown in the directions, for two-way messages for sending and receiving. No trouble at all to operate with the simple instructions that accompany each set. Operates on any standard dry battery obtainable everywhere. With this outfit you can learn to transmit and receive messages by the Morse International Code, and in a very short time become an expert operator. Mounted on wooden base measuring 4 1/2 inches. In clear construction throughout. Complete with key, sounder, magnet, micro relay, Western Union blanks, packed in a neat box with full illustrated instructions. **L. F. R 15c (without battery) Postpaid.**

PISTOL CIGARETTE CASE



It looks like a deadly weapon, but it is merely a novel Cigarette Case. This clever contrivance has proved itself better than the real thing in many an awkward encounter. Great fun "sticking up" your friends. They squirm and protest it might be loaded. Pull the trigger and the slide files open disclosing the cigarettes. Well made, light and compact. **Weight only 2 ounces. PRICE POSTPAID 25c**

NOVELTY FRENCH PHOTO RING



A classy looking ring, with imitation platinum finish, set with large imitation diamond. In the shank of the ring is a small microscopic picture, almost invisible to the naked eye, yet is magnified to an almost incredible degree and with astonishing clearness. There are pictures that should suit all tastes, such as bathing girl beauties, pretty French actresses in interesting poses, also views of places of interest in France, Panama Canal and elsewhere; others show Lord's Prayer or Ten Commandments in type. State wishes and we will try and please you. **PRICES 25c, 3 for 65c, or \$2.25 per doz postpaid. Add 10c for 770 page catalog. Shows many other photo novelties. The world's greatest assortment of novelties, jokes, tricks, puzzles, etc. No other catalog like it anywhere.**

MAKE YOUR OWN RADIO



Enjoy the concerts, baseball games, market reports, latest news, and much more. This copyrighted book "EFFICIENT RADIO SETS" shows how to make and operate inexpensive radio sets for which can be purchased for a mere trifle. Also tells how to build a short-wave Receiver for bringing in foreign stations, police calls, noise at sea, etc. **ONLY 15c. postpaid.**

SILENT DEFENDER



Used by police officers, detectives, sheriffs, night watchmen and others as a means of self-protection. Very effective. Easily fits the hand, the fingers being grasped in the four holes. Very useful in an emergency. Made of aluminum they are very light, weighing less than 2 ounces. Handy pocket size always ready for instant use. **PRICE 25c each, 2 for 45c postpaid. Catalog 10c**

WONDERFUL X-RAY TUBE

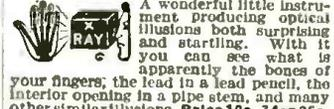

A wonderful little instrument producing optical illusions both surprising and startling. With it you can see what is apparently the bones of your fingers; the lead in a lead pencil, the interior opening in a pipe stem, and many other similar illusions. **Price 10c, 3 for 25c.**

Exploding Matches

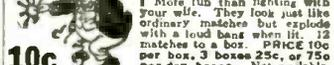

More fun than fighting with your fists. They look just like ordinary matches but explode with a loud bang when lit. **12 matches to a box. Price 10c per box, 3 boxes 25c, or 75c per doz. boxes. Not available by Express.**

ITCHING POWDER



This is another good product! **Itches the intense discomfort of four victims to everyone, but themselves!** It is thoroughly enjoyable. All that is necessary to start the ball rolling is to deposit a little of the powder on a person's hand and the powder can be relied upon to do the rest. The result is a vigorous scratch, then some more scratch, and all some more. **10c per box, 3 boxes 25c or 75c per dozen. Shipped by Express.**

ANARCHIST BOMBS



One of these glass vials dropped in a room full of people will cause more consternation than a hamburger cheese. The small article disappears in a short time. **10c per box, 3 boxes for 25c, 75c per doz. Boxes 25c. 3 for 75c. Gross Boxes. Shipped by Express. Not Prepaid.**

SNEEZING POWDER



Place a very small amount of this powder on the back of your hand and blow it into the air, and watch them sneeze without knowing the reason why. It is most amusing to hear their remarks, as they never suspect the real source, but think they have caught it one from another. Between the laughing and sneezing you yourself will be having the time of your life. For parties, political meetings, car rides, or any place at all where there is a gathering of people, it is the greatest joke out. **PRICE 10c, 3 for 25c, 75c per dozen. Shipped by Express. Not Prepaid. 770 page Novelties Catalog 10c.**

COMICAL MOTTO RINGS



Lots of harmless fun and amusement wearing these rings. Made in platinum finish (to resemble platinum), with words on enamel, as illustrated. **Price 25c. 3 for 75c. Postpaid.**

MAGIC MADE EASY 250 MAGIC TRICKS



An excellent little book containing 250 Parlor Tricks, tricks for boys, card tricks, handkerchiefs, eggs, rings, glasses, etc. So simple that a child can perform them. Profusely illustrated. Sent postpaid to where there is an address for only 10c. 3 copies for 25c postpaid.

ADDRESS ORDERS FOR ALL GOODS ON THIS PAGE TO **JOHNSON SMITH & CO. DEPT. 969 Racine, Wis.**

Capacity Bridge

● MOST "hams" would like to know the capacity of their condensers which they have salvaged from old sets. Most capacity bridges cost plenty of money, but this one costs no more than one dollar to make. To make it one needs: one 50,000 ohm fixed resistor and one 50,000 ohm variable resistor, one .0005 fixed condenser and one .0005 mf. variable condenser (straight-line capacity), binding posts, wire, 0-100° dial, and other small parts

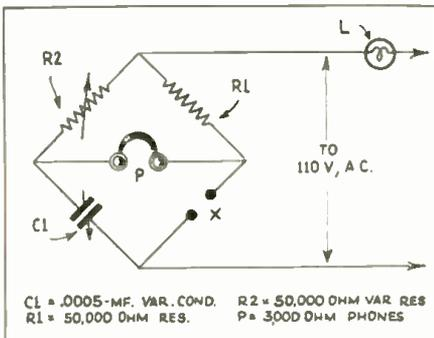

How to Connect a Capacity Bridge

found in the "junk box." Phones of about 3000 ohms work best for this bridge and the circuit is so simple that it needs no explanation.

Turn the variable condenser to full capacity or with the plates fully meshed and connect the posts of the .0005 fixed condenser across the binding posts X. It may be necessary to connect a 25 watt lamp in series with the 110 volt alternating current to prevent burn-outs if your condenser to be tested is shorted. Now with the phones connected you will hear the 60 cycle A.C. hum. By turning the variable resistance and listening closely you will be able to establish the point where the hum fades out entirely. The resistor then should be locked at this point because the circuit is now balanced.

Each point on the dial equals .000005 mf. For example, a reading of 50 on the dial equals .00025 or a reading of 25 on the dial equals .000125. To use the bridge hook the unknown condenser across the binding posts X, turn the variable condenser until no hum is heard, note dial reading and multiply by .000005. If you have no variable condenser of .0005 take a fixed condenser with a capacity of .0005 and hook it in place of the variable condenser. Then procure a .0005 fixed condenser, hook across binding posts X, and turn the resistor until no hum is heard in the phones. Now, remove the condenser which is hooked across the binding posts, X, and gather all your variable condensers together. Mesh the plates and connect them one by one across binding posts, X, until no sound is heard in the phones. The condenser that causes no sound to be heard in the phones has a capacity of .0005. Then remove the fixed condenser which was used in place of the variable condenser and substitute the variable condenser which has a capacity of .0005.

The base board is taken from a prunox box and measures 9" x 6" x 1/2" and is of pine. There is no special order of the parts on the board. If one so desires you can hook on a 0 to 80 A.C. milliammeter instead of head phones and have a visual tuning. No hum, the milliammeter will drop to nearly zero.—Edward F. Felzer.

IN NEXT ISSUE

Mr. Victor tells you how to add "PHONE" to the Amateur Transmitter.

DON'T MISS IT!

No More Computing Short-Wave Coils!

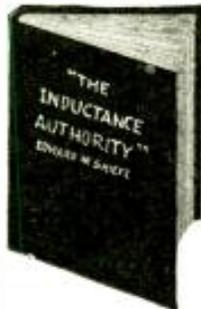

FIGURING out inductance required and numbers of turns of wires of various sizes to establish such inductance is a tedious process, especially as so much trying of this and that has to be done before the accurate result is achieved. But now no more computation of short-wave solenoids is necessary—or any solenoids for any radio frequency—because the answers obtained after 400 hours of computation are reduced to curves on plotting paper in a new book, "The Inductance Authority," by Edward M. Shiepe, B. S. (Massachusetts Institute of Technology), M. E. E. (Polytechnic Institute).

The only book of its kind in the world, "The Inductance Authority" entirely dispenses with any and all computation for the construction of solenoid coils for tuning with variable or fixed condensers of any capacity, covering from ultra frequencies to the borderline of audio frequencies. All one has to do is to read the charts. Accuracy to 1 per cent may be attained. It is the first time that any system dispensing with computation has achieved such very high accuracy and at the same time covered such a wide band of frequencies.

A condensed chart in the book itself gives the relationship between frequency, capacity and inductance, while a much larger chart, issued as a supplement with the book, at no extra charge, gives the same information, although covering a wider range, and the "curves" are straight lines. The condensed Tri-Relationship Chart is in the book so that when one has the book with him away from home or laboratory he still has sufficient information for everyday work, while the supplement, 18 x 20 inches, is preferable in the laboratory for the most exacting demands of accuracy and wide frequency coverage.

The answers to coil problems are obtained in a jiffy by consulting "The Inductance Authority", and obtained accurately. 9x12" Flexible Black Cover Price, \$2.00 per copy postpaid on receipt of remittance with order. 18x20" Tri-Relationship Chart, a supplement to the book, is included in this price.

Published by Herman Bernard

From the tri-relationship chart (either one), the required inductance value is read, since frequency and capacity are known by the consultant. The size and insulation of wire, as well as the diameter of the tubing on which the coil is to be wound, are selected by the user, and by referring to turns charts for such wires the number of turns on a particular diameter for the desired inductance is ascertained.

There are thirty-eight charts, of which thirty-six cover the number of turns and inductive reactance for the various wire sizes used in commercial practice (Nos. 14 to 22), as well as the different types of covering (single silk, single cotton, double silk, double cotton and enamel) and thirteen diameters of 3/8, 1/2, 5/8, 1, 1 1/4, 1 1/2, 1 3/4, 2, 2 1/4, 2 1/2, 2 3/4 and 3 inches.

Each turns chart for a given wire has a separate curve for each of the thirteen form diameters.

The two other charts are the tri-relationship one and a frequency-ratio chart, which gives the frequency ratio of tuning with any inductance when using any condenser the maximum and minimum capacities of which are known.

The book contains all the necessary information to give the final word on solenoid coil construction to service men engaged in replacement work, home experimenters, short-wave enthusiasts, amateurs, engineers, teachers, students, etc.

The curves are for close-wound inductances, but the text includes information on correction factors for use of control winding, as well as for inclusion of the coils in shields.

This is the most useful and practical book so far published in the radio field, in that it dispenses with the great amount of computation otherwise necessary for obtaining inductance values, and is highly accurate.

DIAL-CALIBRATED OSCILLATOR

HERE is the very test oscillator you need most—one that works on a.c., d.c. and also on batteries. For a.c. simply plug into the 110-volt line. For d.c. simply plug into the d.c. line, observing the polarity marked on the cable plug. For battery use simply connect 90 volts of B battery to the plug otherwise inserted in the wall outlet, observing polarity. The output is always modulated.

The fundamental frequencies are 134 to 402 kc. and they are imprinted on the dial scale, which is therefore direct-reading. Many intermediate frequencies are read right on the fundamental scale. Higher intermediate frequencies (400 to 500 kc) are obtainable by using the second harmonic of fundamentals between 200 and 250 kc, and the popular intermediate frequencies in the second-harmonic region are imprinted right on the scale. Besides, the broadcast band is covered by the fourth harmonic (536 to 1608 kc), with the scale calibrated for this region also.

With this test oscillating there is no confusion due to multiplicity of harmonics, as up to the highest broadcast frequency no harmonic higher than the fourth is used. With more numerous response points the oscillator may be used for all short waves to 10,000 kc (30 meters), for peaking, but not for measuring frequency, as the harmonic responses then are too numerous.

A 31 tube is required.



The Bernard test oscillator is made to fill the need for accuracy at low cost, plus portability and universality, so that no matter where a service man goes, if he has a Bernard oscillator with him, he will never be at a loss for a generator of frequencies. Every set-owner has a c. or d.c. or batteries and therefore supplies all the power necessary to run the test oscillator. No separate "A" voltage source is needed.

The accuracy is always 2 per cent or better, usually around 1 per cent. (Manufactured by Herman Bernard)

\$4.45

(Less Tube)

Herman Bernard

135-G Liberty St.
New York, N. Y.

The "EAGLE", a new sensational 3 tube S.W. Receiver

The only popular priced set having the band spreading feature

\$11.95 Price Being Increased Next Month

CHECK THESE FEATURES!!

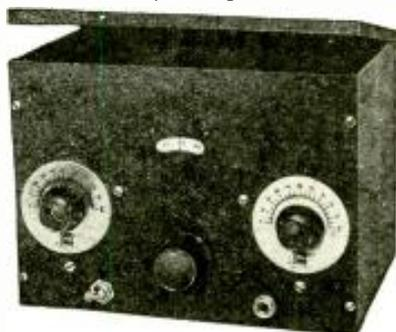

- SCREEN GRID 232 R.F. and screen grid detector offering highest possible gain and most efficient regeneration.
- PENTODE POWER AUDIO—233 gives more audio gain than obtained from two ordinary transformer-coupled stages. Will operate speaker on most stations.
- TANK CONDENSER—is operated from the front of panel and eliminates the objectionable necessity of lifting the cover. Speedy range changes at your finger tips. The ADJUSTABLE condenser employed here gives much finer tuning than is possible with the ordinary large condenser.
- BAND SPREADING CONDENSER—very small capacity permits widest possible calibration spread over a multitude of ranges. This feature gives you really two receivers for the price of one.
- DIAL—Latest design, real vernier control over any position of the frequencies covered. Absolutely will not jump or slip—very rugged.
- REGENERATION CONTROL—Employs condenser for stability, ruggedness and velvet-like smoothness, not noisy like resistances.
- POWER CABLE—Eliminates possibility of wrong connections and insures absolute electrical contact.
- CABINET—Size 6" x 7" x 9 1/2", metal, compact, hinged cover, crystallized finish. Completely shields the receiver. Also ideal for portable use.
- RANGE—15 to 200 meters—4 plug-in coils are supplied with each receiver. The "EAGLE" completely wired and tested. Price..... \$11.95
- TUBES—Set of 3 tubes..... \$3.00

Read the complete write-up of the EAGLE in the August issue SHORT WAVE CRAFT.

GROSS RADIO, Inc.,

51 Vesey St., Dept. C, New York City
Tel. Barclay 7-0161



Greatest Short Wave News!

WE are pleased and proud to announce the greatest and most complete work on **SHORT WAVES** which has ever appeared in print.

There has been a big boom in short waves during the past two years in spite of the depression. Tremendous progress has been made, yet up to now there has not been an adequate book depicting ALL the progress that has been made.

THE OFFICIAL SHORT-WAVE RADIO MANUAL now fills this need completely. It is a big book in which you will find EVERYTHING in short waves, no matter what it may be. It is not only a complete manual, but it is a veritable encyclopedia of facts, information, hookups, illustrations. It is impossible to explain the entire volume in a few sentences.

The book has been edited by Hugo Gernsback, Editor of **SHORT WAVE CRAFT**, and H. W. Secor, Managing Editor, and if you are a reader of **SHORT WAVE CRAFT** and have seen some of Mr. Gernsback's other publications, you know just about what you may expect from this, his *greatest effort in the short-wave field.*

Here are the contents of the book:

14 NEW, BIG FEATURES

- 1. **THE LARGEST SECTION**, featuring the most important short-wave receivers and how to build them. **EVER ASSEMBLED BETWEEN TWO COVERS.**
- 2. Short wave amateur transmitters in all their phases.
- 3. A complete Ultra Short Wave section featuring construction of 1, 3, 5 and 10 meter receivers.
- 4. A complete Short Wave beginner's section.
- 5. A large section devoted exclusively to short wave coil winding and all about it.
- 6. The most complete section of commercial short wave receivers in print. Every important commercial Short Wave receiver (this includes all wave receivers) is represented **WITH FULL SERVICING data. Invaluable for Service Men.**
- 7. A large section devoted to A, C, short wave power packs and how to build them, from 1 to 7 tube receivers.
- 8. A big section for the Short Wave experimenter on short-wave kinks—hundreds of them.
- 9. A section on the important new art of short-wave therapy (treatment of diseases by short waves).
- 10. A section devoted exclusively to Short wave converters. This includes how to build them, as well as commercial models with **FULL SERVICING DATA.**
- 11. An important section on Short Wave antennae and noise eliminating procedures.
- 12. The most complete section of Short Wave Superheterodynes in print. This section includes both how to build as well as commercial models of receivers. The latter with full service data.
- 13. A section on amateur 'phone transmitters and how to build them.
- 14. A Short Wave Physics section on theoretical Short Wave data for the advanced experimenter, as well as student.

Special pre-publication offer: You now have the opportunity to order this book before it comes off the press and save money. The price of the new **OFFICIAL SHORT-WAVE RADIO MANUAL** will be \$2.50 as soon as it comes off the press (early in October). No reduction in price will be made later. To you who order this book before publication the price is \$2.00. As soon as the **OFFICIAL SHORT-WAVE RADIO MANUAL** is published the pre-publication price will be immediately withdrawn. It is to your advantage to order your copy today.

IMPORTANT!

Inasmuch as this is the first time that such a monumental work in short waves has been published, Mr. Hugo Gernsback has consented to personally autograph the first one thousand copies, all of which are numbered. If you wish an autographed copy of the Manual, place your order immediately.

Over 200 big pages
Over 1,000 illustrations
Size 9x12 inches
Flexible, loose-leaf covers

Clip—Mail This Coupon Today!

SHORT WAVE CRAFT,
96-98 Park Place,
New York, N. Y.

Gentlemen: I enclose herewith my remittance of \$2.00 for which please send me one copy of the 1934 **OFFICIAL SHORT-WAVE RADIO MANUAL**, at the pre-publication price of \$2.00. I understand that the price of the book will be \$2.50 as soon as it is published. (Send remittance, check or money order. Register letter if it contains cash or currency.)

Name

Address

City

State

for the RADIO *Experimenter* AND Constructor

Send for our New 16-page
Catalog. Use Coupon below.

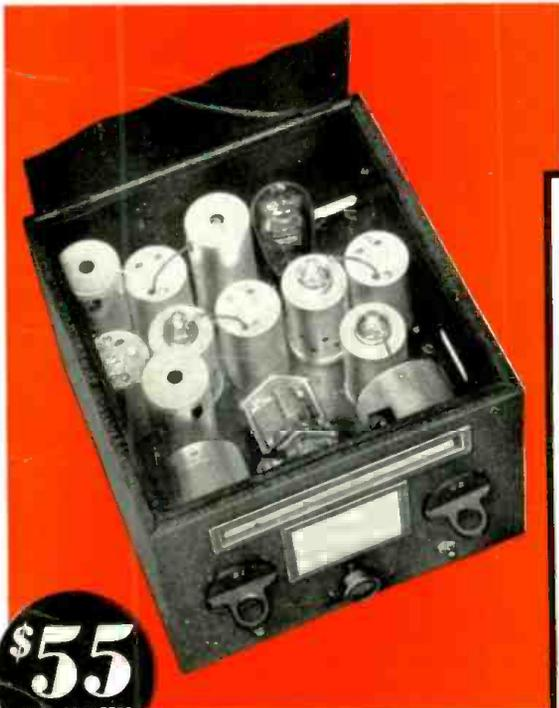

\$55
WITH 80 METER
COILS, LESS TUBES

FB-7 SHORT-WAVE SUPER

When you see and operate the FB-7 you will understand why this seven-tube short-wave superheterodyne receiver has become so popular not only with the experienced amateurs for whom it was designed—but with short-wave broadcast listeners everywhere. It was built to contend the crowded conditions of the amateur C.W. and phone bands. Two stages of high-gain I.F. amplification (six tuned circuits) give very high sensitivity and selectivity. All circuits are individually filtered, and shielding is unusually thorough, resulting in high stability. Class A Pentode audio output assures ample volume and quality. Full range 9 to 200 meters. Our new catalog gives all the features—many of them exclusive—of this outstanding receiver.

ALL NATIONAL Short-Wave Parts are precision-designed and made by a Company which has been known for the excellence of its products since its establishment in 1914.

\$24.50
LESS COILS
AND TUBES



SW-3 AMATEUR RECEIVER

The famous NATIONAL Thrill Box, made for amateurs. High signal-to-noise ratio. . . . High R.F. gain through use of 58 tubes. . . . Genuine single control. List price: \$24.50, less coils. . . . Imiti spread coils, \$4.75 per pair. Full line of standard R-39 coils for complete coverage from 9 to 2000 meters.



MIDGET H.F. CONDENSERS

National Co. makes a full line of 52 different models of short-wave and ultra-short-wave variable condensers. All midgets have Isolantite Stator insulation, no shorted-turns. . . . constant impedance rotor-connections to eliminate crackle and noise, mechanical rigidity, and electrical stability. Fully listed in Catalog No. 215. Typical examples are:
 SEU-15—15 mmf., 270° SFL plates, air-gap .055"
 STH-200—200 mmf., 180° SFL plates, air-gap .017"
 SS-50—50 mmf., 180° SLC plates, air-gap .026"
 SE-100—100 mmf., 270° SFL plates, air-gap .026"



COIL AND TUBE SOCKETS

These new NATIONAL Isolantite sockets, designed specifically for short-wave service, will reduce losses at this point to a minimum. Made with convenient prong-guiding channel, and in 4, 5, 6, and 7-prong styles.



FRONT-OF-PANEL-CHANGE COIL FORMS AND SOCKETS

Bring your short-wave receiver up to date with coils wound on NATIONAL Regular and Band-Spread Coil-Forms with grommets and shielded cast-metal handles, and built-in air-dielectric padding condensers—as used in FB-7 and FB-X Receivers. These forms are made to fit the NATIONAL special 6-prong front-of-panel coil-socket with aluminum shield and external terminal strip.



STANDARD R-39 FORMS

These forms are made of the easily drilled R-39, the special high-efficiency dielectric for short-wave work. Reduces losses—will not deteriorate. Made in 4, 5 and 6-prong models. Fit NATIONAL sockets.

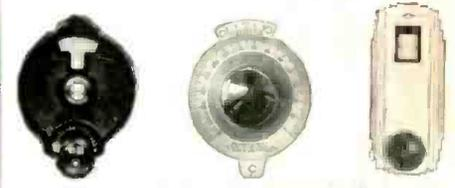

NATIONAL VELVET-VERNIER DIALS

Standard in short wave work for many years. Made in a number of different types—with disc and drum dials, or in solid german-silver with precision vernier-scale;—in illuminated and non-illuminated types—all with the precise smooth drive that has made the name Velvet-Vernier famous wherever radio is used,—and all made to give years of exacting service.

AIR DIELECTRIC TUNED I.F. TRANSFORMERS

With micrometer-tuned air-dielectric double-bearing precision condensers, velvet-vernier type, self-locking rotors, Isolantite insulation, and all peaking adjustments easily made from top of shield. 450-500 k.c. range. Coils are latest type, litz-wound. Especially fine in tropics or in damp climates.



Send Coupon Today!

NATIONAL CO. INC.,
61 Sherman St., Malden, Mass.

Gentlemen: Please send me your new catalog No. 215, giving prices and particulars of NATIONAL RADIO PRODUCTS. I enclose 6c in stamps to cover mailing costs.

Name _____

Address _____

SW-10-33



NATIONAL RADIO-FREQUENCY CHOKES

Type 100—Isolantite mount for clips or solder connections. 125 M.A., 2½ millihenries, 50 ohms D.P. resistance.
 Type 90—For by-pass work on screen-grid or plate circuit of screen-grid tubes and between detector and 1st audio. Ind. 90 m.h.
 Type R-152—Transmitting I.F.P. Choke. 10,000 volts insulation. 4 m.h., D.C. resistance 10 ohms, 0.6 amps continuous rating.

Type R-200—High impedance choke for output of 2nd detector. used in AGS and PB-7. Inductance 90 m.h. cased in R-39. (Not illustrated).



COIL AND TUBE SHIELDS For the Home-Constructor

Type J-30—Coil Shield, 2½" diam., 3¾" high, square bottom flange.
 Type B-30—Coil Shield, 3" diam., 3¾" high, separate mounting base.
 Type TS—Tube Shield, with Top Cap and Bottom Mounting Plate.
 Type T-58—Tube Shield (4 piece), for use with 57 and 58 tubes.



NATIONAL GRID-GRIPS

Known and used the country over. For attaching lead to screen-grid terminal of A.C. or D.C. screen-grid tubes. In two sizes, for standard and large type tubes.

NATIONAL PRECISION SHORT-WAVE EQUIPMENT

Choice of the Expert

THE SUPER QUALITY RADIO TUBE



Licensed Under RCA Patents

—

Guaranteed

Van Dyke
RADIO TUBES
for
SHORT WAVE
TELEVISION
TRANSMITTING

Now! Ninety-two types of tubes under the famous VAN DYKE trade mark. Visit your nearest S. S. KRESGE CO., green front store for your tube requirements.

Manufactured for and Sold Exclusively by
S. S. KRESGE COMPANY—25c to \$1.00—GREEN FRONT STORES

Van Dyke Laboratories
E. Newark, N. J.